

THE INFORMATION CONTAINED IN THIS DRAWING IS THE SOLE PROPERTY OF PLASTICASE ANY REPRODUCTION IN PART OR WHOLE WITHOUT THE WRITTEN PERMISSION OF PLASTICASE IS PROHIBITED.

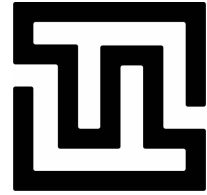

**INSTRUMENTS  
TECHNO  
TEST**

REVISIONS			
REV.	DESCRIPTION	DATE	APPROVED

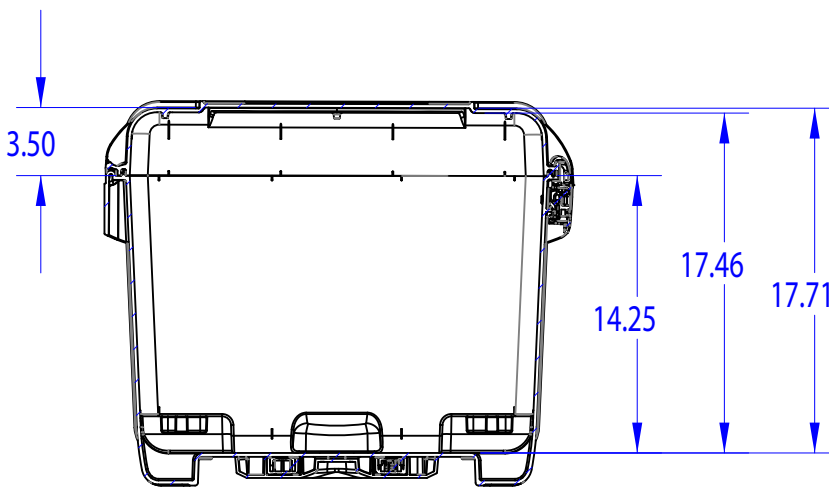
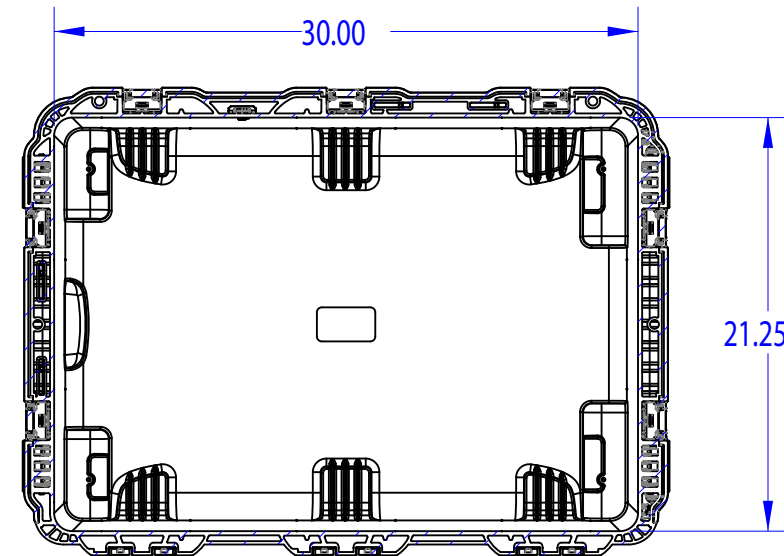
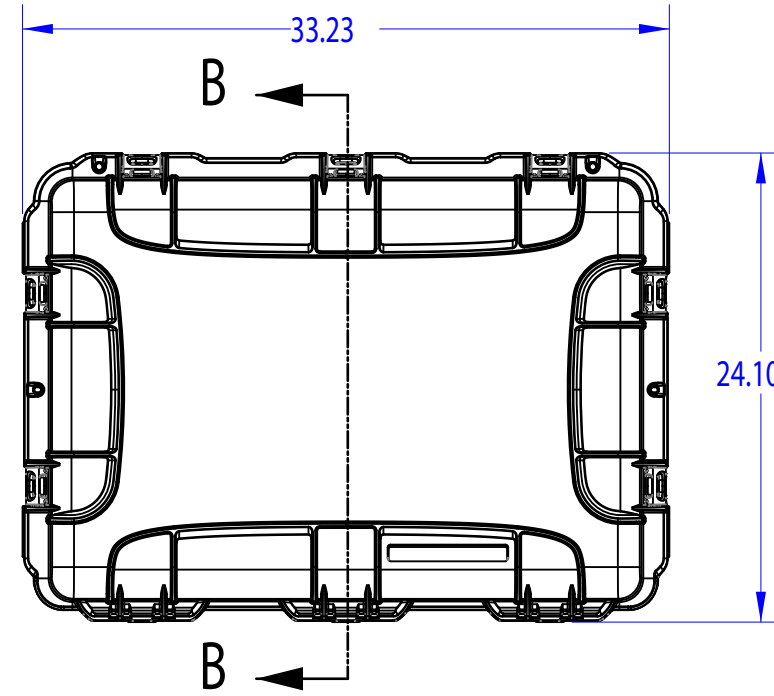
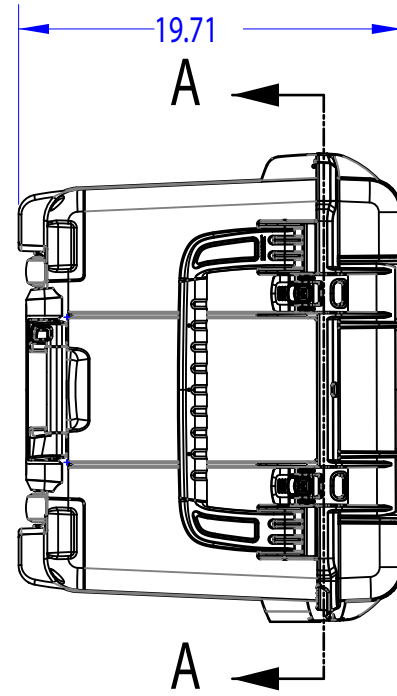
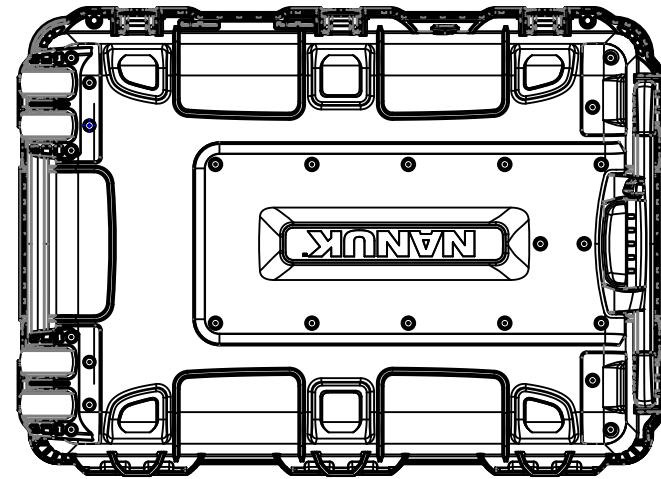
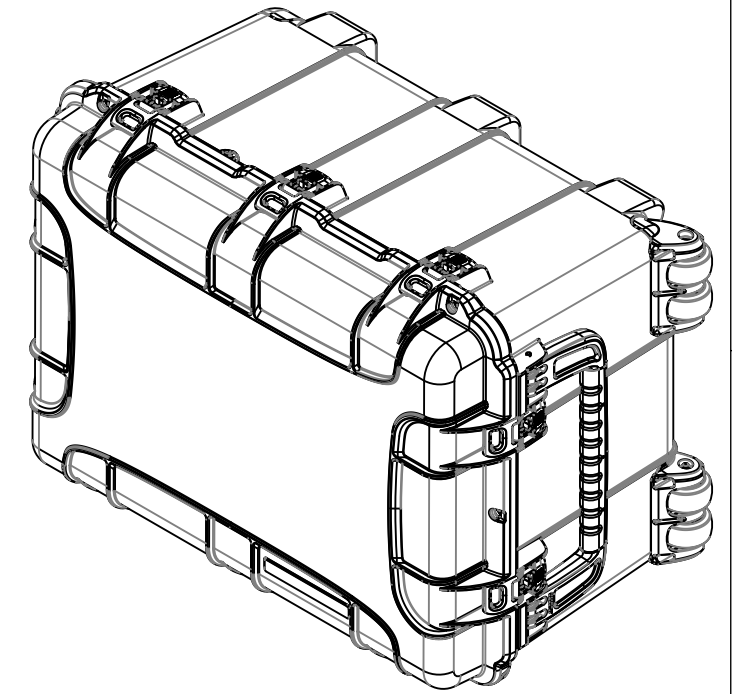

SECTION A-A

SECTION B-B

**NANUK 975 Specifications**

Case Weight Empty	32.2 lbs / 14.60 kg
Interior Length	30" / 762 mm
Interior Width	21.25" / 540 mm
Interior Height	17.4" / 443mm
Interior Lid Depth	3.5" / 89 mm
Interior Base Depth	14.25" / 362 mm
Exterior Length	33.2" / 843 mm
Exterior Width	24.1" / 612 mm
Exterior Height	19.7" / 500 mm
Master Pack Qty.	1
Master Pack Wt.	TBD
Max Buoyancy	TBD

PARTS LIST			
UNLESS OTHERWISE SPECIFIED DIMENSIONS ARE IN INCHES	CAD GENERATED DRAWING, DO NOT MANUALLY UPDATE		<b>PLASTICASE</b>  <b>NANUK 975</b>
	APPROVALS	DATE	
	DRAWN S.C.	2021-07-20	
	CHECKED		
MATERIAL	RESP ENG		
FINISH --	MFG ENG		
DO NOT SCALE DRAWING	QUAL ENG		
SCALE 1:10	CAD FILE: 975_Assembly_a.01	SHEET 1 OF 1	REV.