

THE INFORMATION CONTAINED IN THIS DRAWING IS THE SOLE PROPERTY OF PLASTICASE ANY REPRODUCTION IN PART OR WHOLE WITHOUT THE WRITTEN PERMISSION OF PLASTICASE IS PROHIBITED.

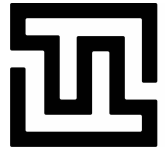

**INSTRUMENTS
TECHNO
TEST**

REVISIONS			
REV.	DESCRIPTION	DATE	APPROVED

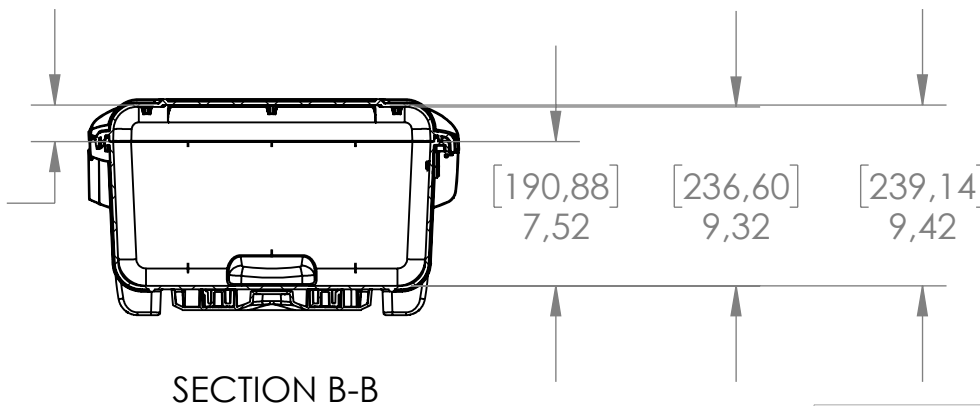
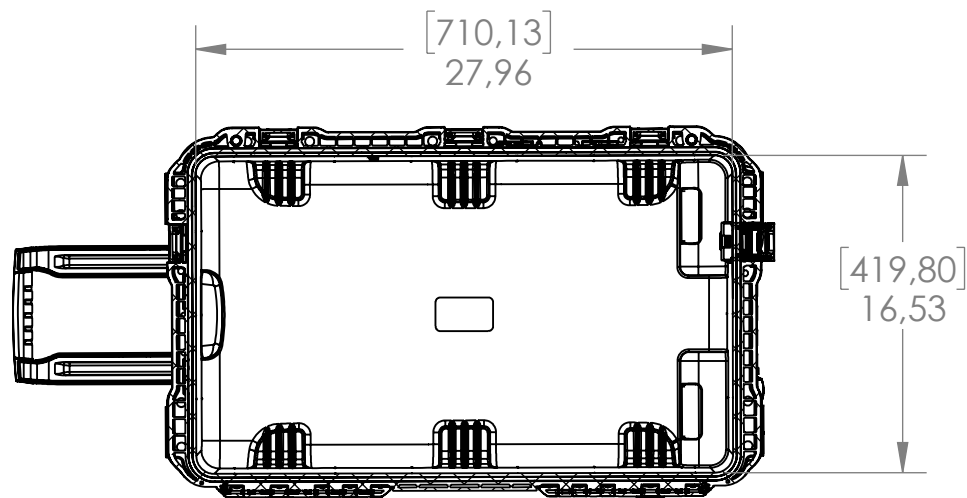
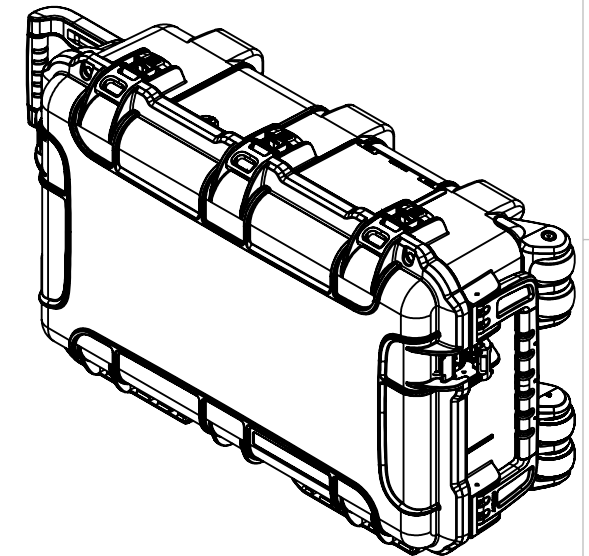
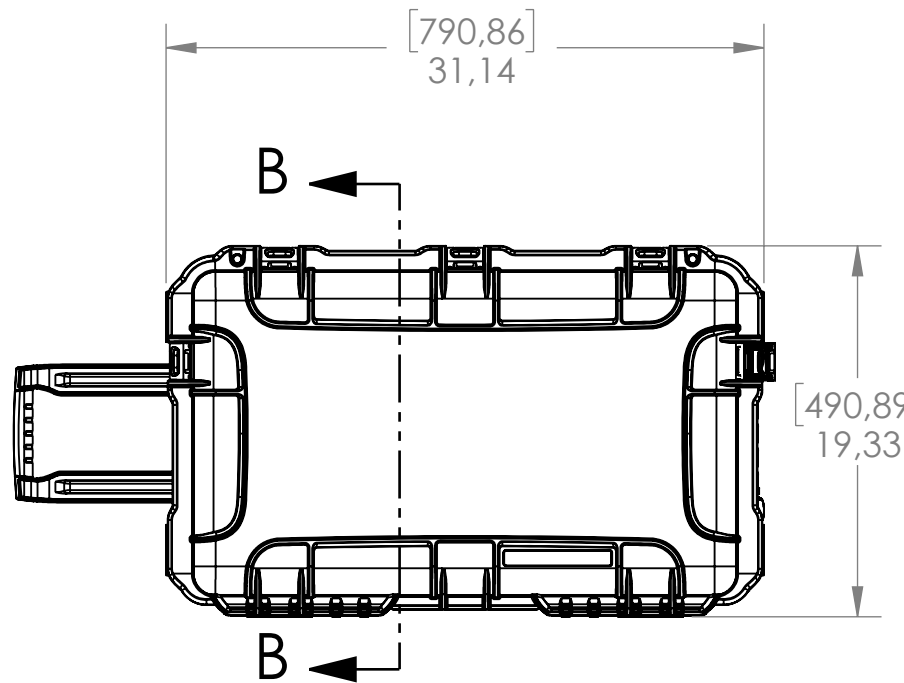
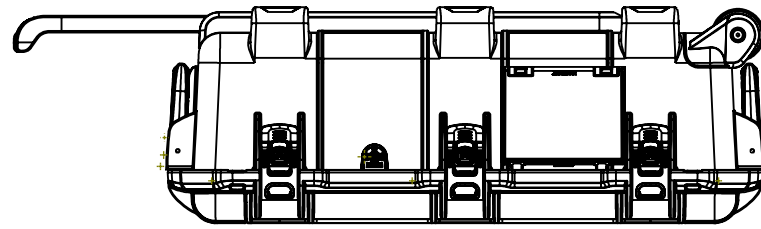
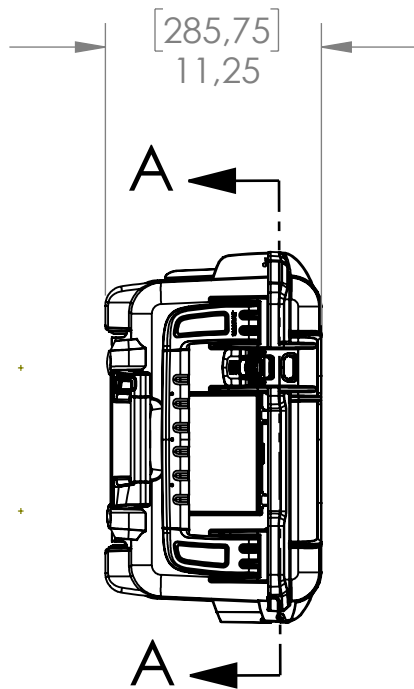
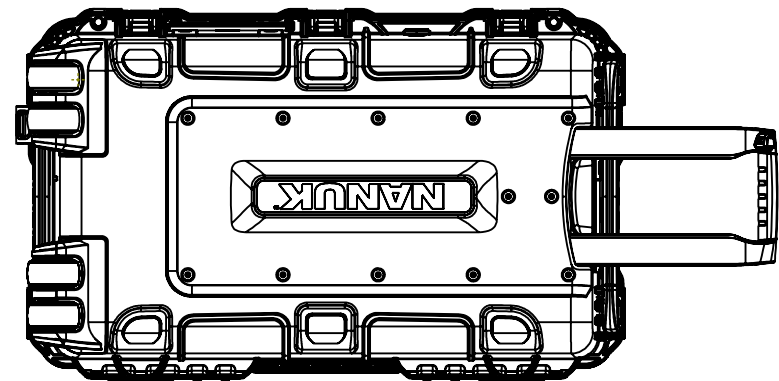

NANUK 962 Specifications	
Case Weight Empty	21.2 lbs / 9.62 kg
Interior Length	28" / 710 mm
Interior Width	16.53" / 419mm
Interior Height	9.32" / 236mm
Interior Lid Depth	1.90" / 48 mm
Interior Base Depth	7.52" / 190 mm
Exterior Length	31.14" / 790 mm
Exterior Width	19.3" / 490mm
Exterior Height	11.25" / 285 mm
Master Pack Qty.	1
Master Pack Wt.	TBD
Max Buoyancy	TBD

SECTION A-A

SECTION B-B

PARTS LIST			
UNLESS OTHERWISE SPECIFIED DIMENSIONS ARE IN INCHES		CAD GENERATED DRAWING, DO NOT MANUALLY UPDATE	
APPROVALS		DATE	
DRAWN	S.C.	2023-01-25	
CHECKED			
RESP ENG			
MFG ENG			
QUAL ENG			
DO NOT SCALE DRAWING			
		PLASTICASE	
		NANUK 962	
SIZE	DWG. NO.	REV.	
B			
SCALE	CAD FILE:	SHEET 1 OF 1	
1:10	975_Assembly_a.01		