

Move into the future with reliable measurements



# CTRS-100 Series

Compact Recorder

# COMPACT & TOUGH

We're changing common sense  
for measuring instruments.



# COMPACT & TOUGH

## Pursuit for simple operation on measurement site CTRS-100 Series

A body that is both compact and resistant to vibrations and shocks.  
High expandability enabling expansion up to 128 channels.  
Expanded possibilities for measurement in hard environments.  
We're changing common sense for measuring instruments.

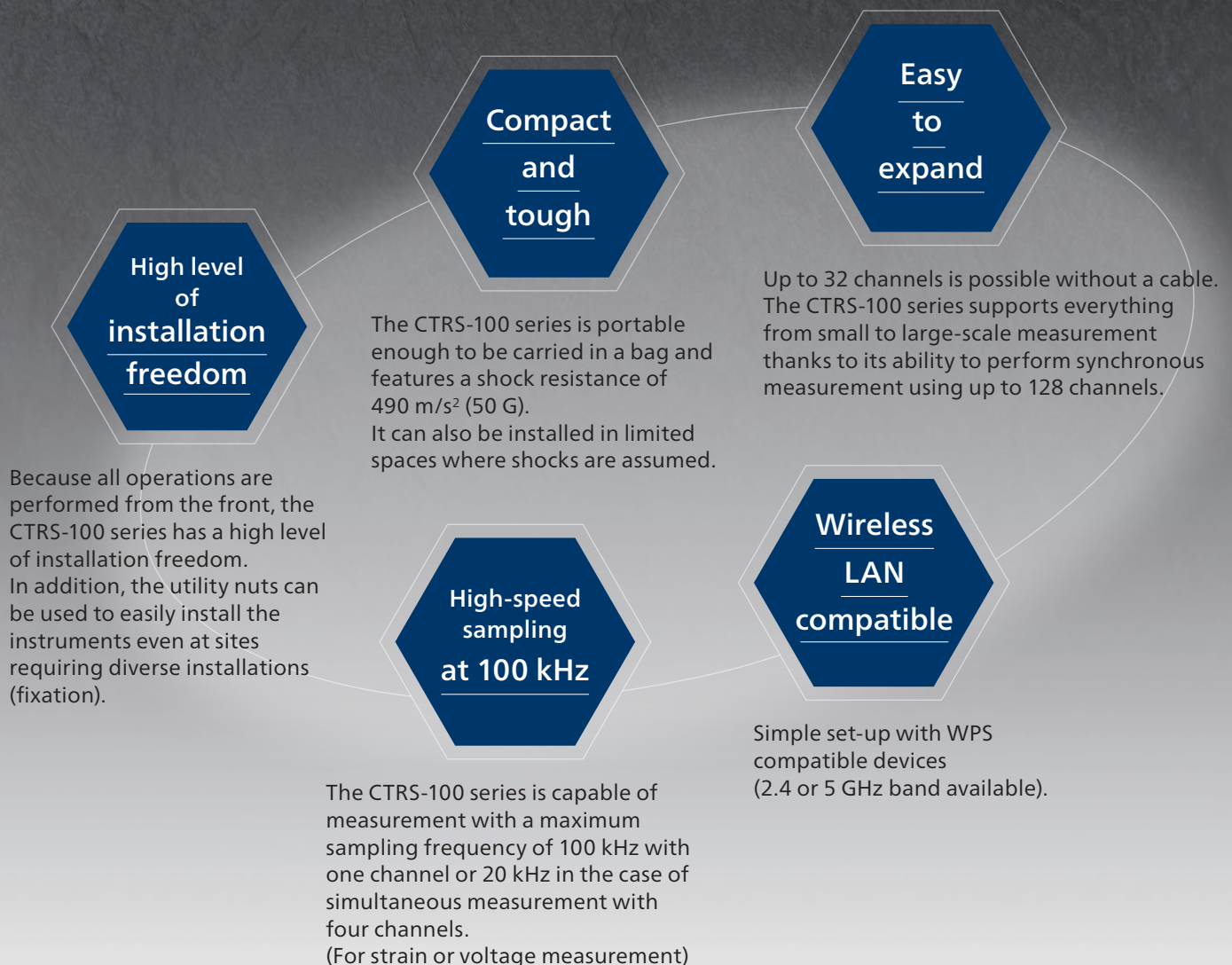



**Compact Recorder**  
A unit for controlling each unit, saving data, and measuring strain and voltage.



**Strain/Voltage Unit**  
A unit for measuring strain and voltage.



**Thermocouple Unit**  
A unit for measuring temperature.

## CTRS-100 SERIES LINEUP



**Battery Unit**  
A power supply unit that enables measurement even at locations without power.



**Synchronization Unit**  
A unit for synchronous operation on 32 channels or more as well as connection with a PC or LAN.



**Wireless LAN Unit**  
A unit for wireless LAN connection. (Certified in radio law in Japan, and U.S.)

# Application

The CTRS-100 series has the excellent ability to perform the various type measurements, no worries to concern about the impact from certain environment. In the limited space, in the field or lab, especially it is exposed with vibrating or crashing. The data will be recorded reliably.\*1

In additional, the CTRS-100 series supports both of standalone recording and online recording via the interface of LAN or USB.



[Research on walking aids]  
Storage in limited spaces

Compact Recorder x1 Battery Unit x1  
Wireless LAN Unit x1

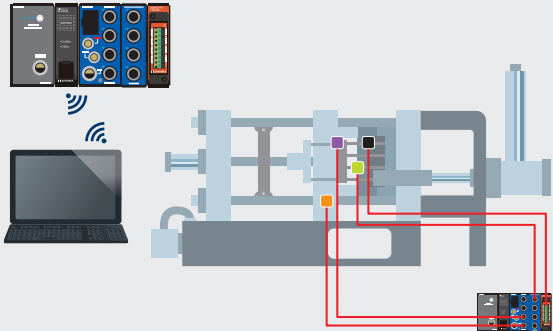

[Multi-channel measurements for molding]  
Select 2.4 or 5 GHz band depending on the environment

Compact Recorder x1 Strain/Voltage Unit x1 Battery Unit x1  
Thermocouple Unit x1 Wireless LAN Unit x1

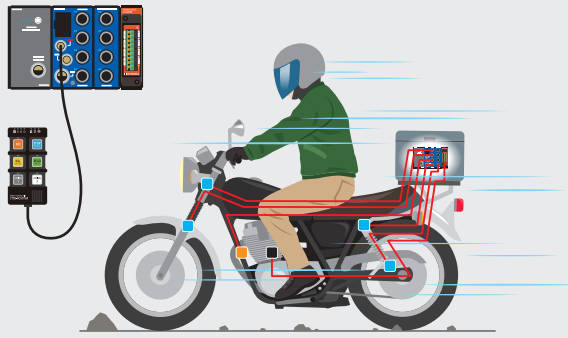

[In-vehicle driving tests of motorcycles]  
Operation in environments with vibrations/shocks

Compact Recorder x1 Strain/Voltage Unit x1 Battery Unit x1  
Thermocouple Unit x1 Remote Control Unit x1

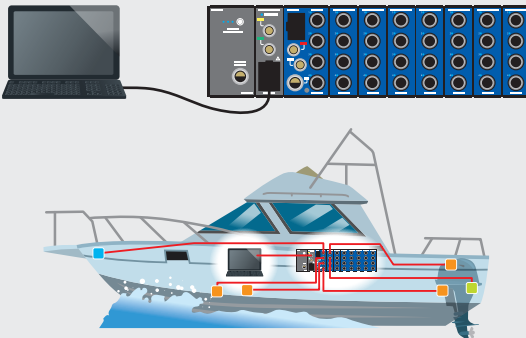

[Full-scale ship tests of cruisers]  
Multi-channel LAN monitoring

Compact Recorder x1 Strain/Voltage Unit x7  
Battery Unit x1 Synchronization Unit x1

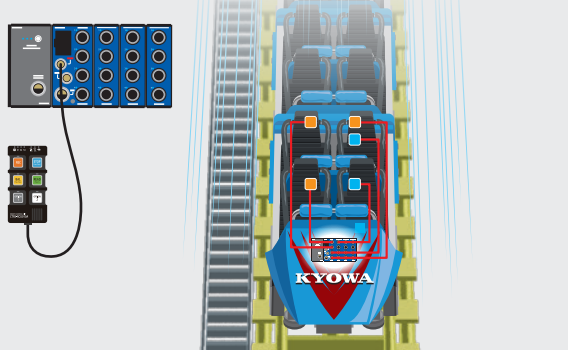

[Driving tests of rides]  
Measurement is possible even with battery power

Compact Recorder x1 Strain/Voltage Unit x3  
Battery Unit x1 Remote Control Unit x1

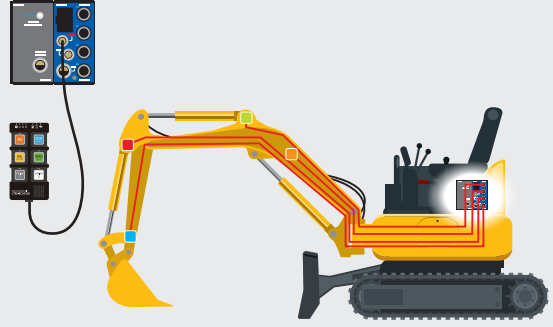

[Actual vehicle tests of construction machinery]  
Installation even in limited spaces

Compact Recorder x1 Battery Unit x1  
Remote Control Unit x1

■ ... Strain Gage\*2   
 ■ ... Acceleration Transducer   
 ■ ... Pressure Transducer   
 ■ ... Load Cell   
 ■ ... Displacement Transducer   
 ■ ... Thermocouple

\*1 The structure is not dustproof or waterproof.    \*2 Bridge boxes are required for strain measurement.

# Configuration (1 to 32 channels)

[For sensors/measurement]

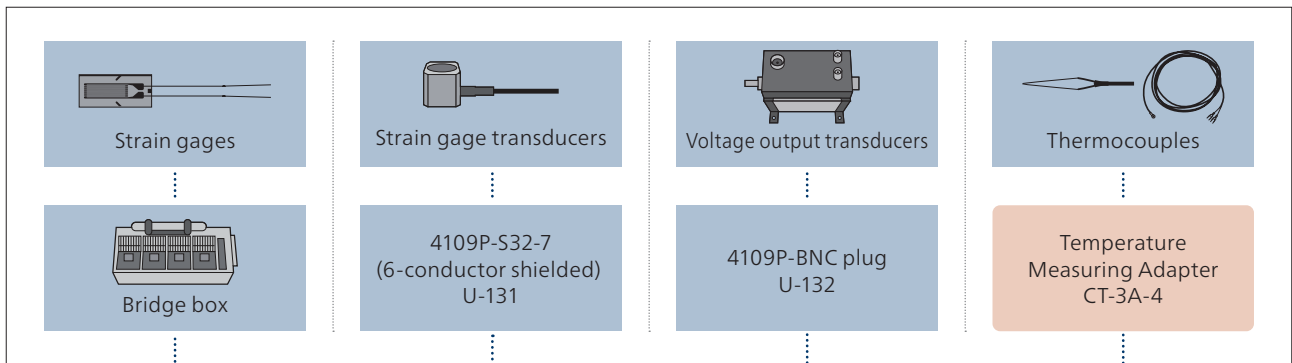

[Main Unit]



[Measuring Units] (Up to 7 units can be connected)

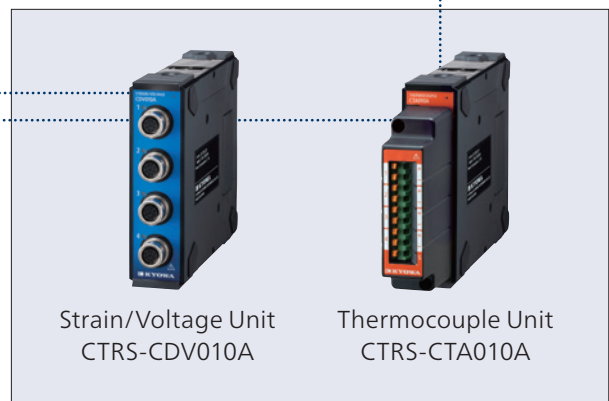

[Control/analysis]

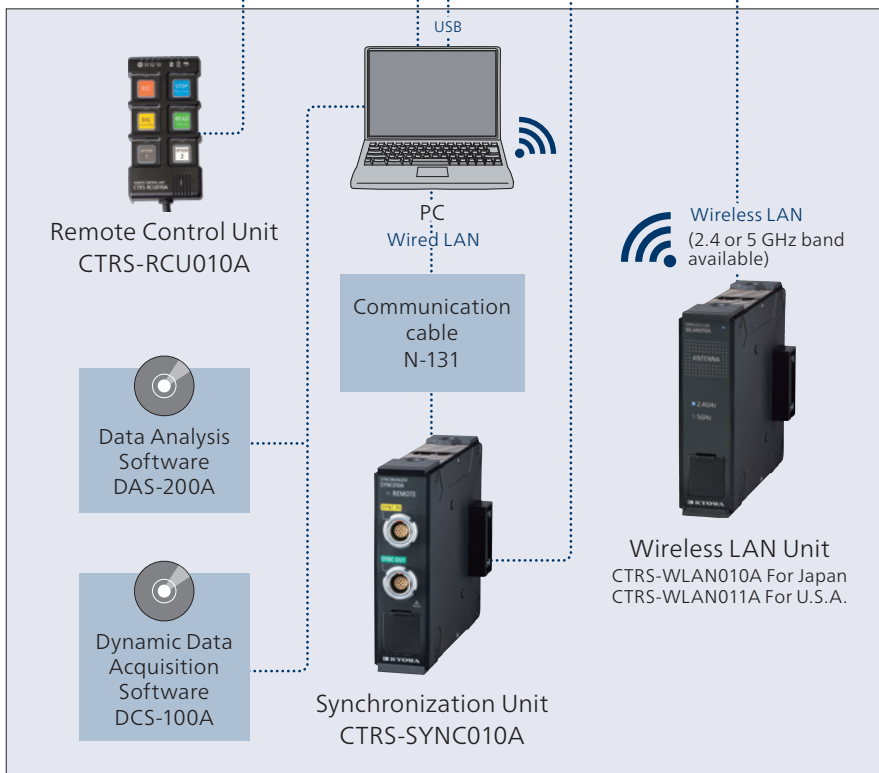

[Power Supply]

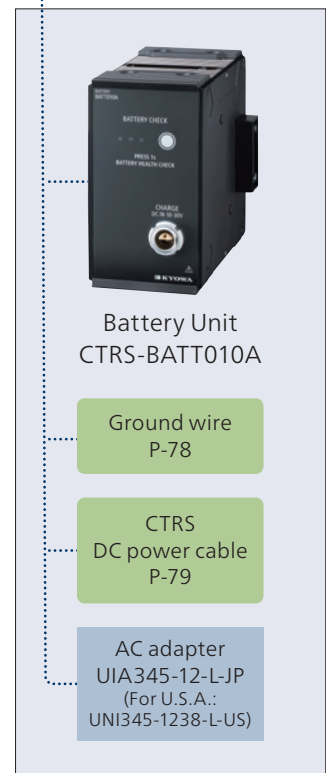

\* The ■ items are standard accessories of the Compact Recorder. No other items are included.  
 \* The ■ items are standard accessories of the Thermocouple Unit. No other items are included.  
 \* For setting the measurement condition and performing online recording, the latest Dynamic Data Acquisition Software is required. If you already have DCS-100A and it is not the latest version, please update it on our official website.  
 \* For standalone measurement, the Remote Control Unit is required.  
 \* For controlling via the interface of LAN, the Synchronization Unit or the Wireless LAN Unit is required.  
 \* One Compact Recorder is able to be combined with 7 measuring units, one Synchronization Unit, one Wireless LAN Unit and one Battery Unit as the maximum structure.  
 \* For details of the Data Analysis Software, contact us.

# [Compact Recorder CTRS-100A Specifications]

Item		Details		
Control Unit Specifications	Connector	USB Connector	Micro USB Type-B	
		Remote Control Connector	Used to connect the remote control unit	
		External I/O Connector	Model: ECA.0B.307.CLN Compatible connector: FGA.0B.307.CLAD52	
	Operating Switch		POWER	
	Main Unit Display		Status LED SD card access indicator LED	
	Data Recording Media		Kyowa recommended industrial-use SD card SD standards: SDHC Capacity: 4 GB, 16 GB Format: FAT32 (Operation is not guaranteed if an SD card other than the recommended product is used.)	
	Communication Interface		USB (USB2.0 High Speed), Ethernet <sup>1)</sup> (10/100BASE-T)	
	Number of Units that Can be Connected	Measuring Unit	Up to 7 units can be connected per CTRS-100A (Total of 32 channels).	
		Expansion Unit	Up to 5 units can be connected per CTRS-100A. However, 2 or more same units cannot be connected and used.	
	Synchronization between Devices	Synchronization Method	Use a synchronization unit and synchronous cable to connect CTRS-100As.	
		Maximum Number of Units that Can Be Synchronized	The maximum is four CTRS-100As, and a maximum of 128 measurement channels can be synchronized.	
		Recorded Data	Data is recorded to each units SD card or a PC. <sup>2)</sup>	
	Recorded Data	File Saving Location	SD card, PC <sup>2)</sup>	
		Data Format	Kyowa standard format KS3	
		Maximum Data File Size	4 GB/1-data-file (1 GB = 1000000000 bytes) <sup>3)</sup>	
		Data Collection	Online collection : Collect by control software (PC) Offline collection : Collect by directly reading data from an SD card to the PC	
	Measurement Condition Setting Method	Online Setting	Set by control software (PC)	
		Offline Setting	Set by reading the measurement-condition settings on the SD card	
	Recording Modes	Manual	The user performs operations to start or stop recording.	
		Trigger (Compound Trigger)	Automatic recording is performed based on the trigger condition setting.	
		Interval	Automatic recording is performed based on the recording start time and recording interval settings.	
	Sampling	Method	Synchronous sampling of all channels	
		Frequency	1-2-5 series 1, 2, 5, 10, 20, 50, 100, 200, 500, 1k, 2k, 5k, 10k, 20k, 50k, 100k Hz 2 <sup>n</sup> series 4, 8, 16, 32, 64, 128, 256, 512, 1024, 2048, 4096, 8192, 16384, 32768, 65536 Hz Maximum sampling frequency that can be set : 100 kHz / number of measurement channels	
		External Clock	Clock input from an external device is used as the sampling clock. A frequency from 1 Hz to 100 kHz can be set in 1-Hz increments. Input a clock within the range of the specified frequency ±5%. Voltage level: High-level voltage 2.4 to 5 V Low-level voltage 0 to 0.8 V DUTY: 30 to 70%	
	Trigger Functions	Trigger Type	·Analog input signal (Analog trigger) ·External trigger input signal (No-voltage contact, open collector, signal with high-level voltage 2.4 to 5 V and low-level voltage 0 to 0.8 V) ·Manual (If the REC button is pressed in the trigger awaiting state, recording starts.)	
		Trigger Level	Any level within the range of ±FS can be set. <sup>4)</sup>	
		Trigger Slope	Slope (positive), slope (negative)	
		Pre-trigger	Specify the amount of data to save from before the start trigger point. Any amount up to 524288 data items/the number of measurement channels can be set.	
	Backup Function	Post-trigger	Specify the amount of data to save from after the end trigger point. Any amount up to 524288 data items/the number of measurement channels can be set.	
		Backup Target	Setting conditions, balance-adjustment value (Zero suppress value)	
External Clock Output	Saving Location	Internal nonvolatile memory		
	Signal Level	5 VDC The inverted or non-inverted signal can be set.		
	Division	A clock signal that is synchronized with the sampling clock is divided and output. Any division ratio in the range from 1 to 65534 can be set.		
Other Functions	Output Modes	Select from always output the clock, only output it while recording, or no output it.		
	Specification of the Number of Data Items to Record	When the specified number of data items is recorded, recording automatically finishes.		
	Automatic Recovery Function in Power Interruption <sup>5)</sup>	While recording, if the power supply is interrupted due to a power outage, etc., you can select whether to switch to battery power and continue recording or close the file being recorded and then shut down. If the option to shut down is selected, you can select whether to resume recording after the power is restored or enter the standby state.		
	Recording Recovery Function	You can select whether to resume recording or enter the standby state when the POWER switch is turned off while recording and then turned back on.		
	File Name Assignment	Automatically assign a file number or recording date to the recorded-data file name.		
Trigger Signal Output		Output a trigger signal when in the trigger (Compound trigger) recording mode. While on standby: 5 VDC, while recording: 0 VDC		

Item		Strain measurement	Voltage measurement		
Measuring Unit Specifications	Channels	4			
	Input Connector	Connector Shape	NDIS4109(Small round 9 pins) receptacle Model: EPRC07-RX9FNDIS		
		Compatible Plug	NDIS4109(Small round 9 pins) plug Model: EPRC07-P9MNDIS		
	Measuring Targets	Strain gages <sup>6)</sup> Strain-gage transducers	Voltage		
	Compatible Bridge Resistance	When bridge excitation is set to 2 V 120 to 1000 Ω When bridge excitation is set to 5 V 350 to 1000 Ω	-		
	Gage Factor	2.00 fixed			
	Excitation Voltage/Sensor Excitation	2, 5 VDC	2, 5 VDC <sup>7)</sup> OFF (0 V)		
	Input Impedance	-	A maximum of 20 mA per channel can be output. 3.6 MΩ±10%		
	Input Modes	Balanced differential input			
	Measuring Range	Setting Method	Any range method or OFF		
		Settable Range	Minimum: 1000 × 10 <sup>-6</sup> strain Maximum: 50000 × 10 <sup>-6</sup> strain	Minimum: 1 V Maximum: 50 V	
		Setting Steps	·1000 to 10000 × 10 <sup>-6</sup> strain 100 × 10 <sup>-6</sup> strain steps ·10000 to 50000 × 10 <sup>-6</sup> strain 1000 × 10 <sup>-6</sup> strain steps	·1 to 10 V 0.1 V steps ·10 to 50 V 1 V steps	

Item		Strain measurement	Voltage measurement	
Measuring Unit Specifications	Range Accuracy		Within ±0.2% FS	
	Nonlinearity		Within ±0.1% FS	
	Temperature Stability	Zero Point	Within ±(0.009% FS + 0.9 × 10 <sup>-6</sup> strain)/°C	Within ±(0.009% FS + 0.21 mV)/°C
		Sensitivity	Within ±0.03%/°C	
	Time Stability	Zero Point	Within ±(0.09% FS + 9 × 10 <sup>-6</sup> strain)/8h	Within ±(0.09% FS + 0.1 mV)/8h
		Sensitivity	Within ±0.3%/8h	
	Balance Adjustment	Setting	For each channel, ON, OFF, or NONE can be selected. ON: Execute balance adjustment and set the measured value to zero. OFF: Do not execute balance adjustment again. NONE: Balance adjustment can be disabled to check the initial unbalanced value (input voltage).	
		Operating Method	Execute the balance operation by using the control software*8 or operate the special-remote-control BAL switch.	
		Adjustment Method	Auto balance (Saved in nonvolatile memory)	
		Adjustment Range	Within ±10000 × 10 <sup>-6</sup> strain	Within ±10 V
		Accuracy	Within ±(0.1% FS + 2 × 10 <sup>-6</sup> strain)	Within ±0.1% FS
		NONE Accuracy	Within ±1% FS*9	Within ±0.2% FS
	Input Range		Within ±60000 × 10 <sup>-6</sup> strain	Within ±60 V
	Common-mode Input Voltage		-	Within ±20 V
	Absolute Maximum Rating	Input	±5 V	±70 V
	Frequency Response		DC to 20 kHz, -3 ±1 dB (at 20 kHz)	
	LPF	Transfer Characteristics	5th-order Butterworth	
		Cutoff Frequency	10, 20, 50, 100, 200, 500, 1k, 2k, 5k, 10k Hz as well as FLAT*10, AUTO*11	
		Amplitude Ratio at Cutoff Point	-3 ±1 dB	
		Attenuation Characteristics	-30 ±3 dB/oct.*12	
HPF	Cutoff Frequency	0.2, 1 Hz and OFF		
AD Conversion	Resolution	24 bits		
	Method	Synchronous sampling of all channels		
Indicator		Channel-status LED		
Other Functions	Input Resistance Check Functions	Bridge resistance check function Accuracy within ±2% Used for sensor connection checks		
	TEDS	Read the TEDS information and apply it to the measurement conditions.*8		
General Specifications	Power Connector		Model: ECP.1S.302.CLL	
	Power Supply		10 to 30 VDC	
	Power Consumption		Approx. 3.5 W (When supplying 12 VDC)	
	Operating Temperature		-10 to 50°C	
	Operating Humidity		20 to 90% (Non-condensing)	
	Storage Temperature		-20 to 60°C	
	Vibration Resistance		49.0 m/s <sup>2</sup> (5 G), 5 to 200 Hz	
	Shock Resistance		490 m/s <sup>2</sup> (50 G), 11 ms or less, half sine wave	
	Dimensions		53.2 W × 92 H × 94 D mm (Excluding protrusions or protectors)	
	Weight		Approx. 420 g	
	Terminal		GND terminal: M3 bind	
	Utility Nuts		Size: M4, 12 places	

- \*1 A separate synchronization unit and special communication cable are necessary.
- \*2 Only when online control is performed by a PC
- \*3 Maximum recording time depends on number of measurement channels and sampling frequency.  
Maximum recording time : 1000000000 ÷ number of measurement channels ÷ sampling frequency
- \*4 Analog input signal only
- \*5 Only when the battery unit is connected
- \*6 A separate bridge box is necessary.
- \*7 When the sensor excitation is 2 VDC, the positive side of the sensor excitation is

- + 1 V and the negative side is -1V. When the sensor excitation is 5 VDC, the positive side of the sensor excitation voltage is + 2.5 V and the negative side is -2.5 V.
- \*8 Only when online control is performed by a PC
- \*9 When the bridge resistance is 350 Ω
- \*10 When FLAT is set, the cutoff frequency is set to approx. 25 kHz.  
However, the cutoff-point amplitude ratio specification is not applied.
- \*11 When AUTO is set, the cutoff frequency is set to approx. 1/4 the specified sampling frequency.
- \*12 Excluding cutoff frequencies over 5 kHz
- \* The measuring unit specifications apply to the state in which the temperature has stabilized after a preheating time of 30 minutes.

**[Standard Accessories]**

- Stack-connector caps (female) ×2
- SD card (4 GB)
- USB cable
- CTRS DC power cable P-79
- Ground wire P-78
- Ballpoint screwdriver
- Input connector caps ×4

**[Optional Accessories]**

- CTRS AC adapter UIA345-12-L-1P (For U.S.A.: UNI345-1238-L-US)
- Various measuring units
- Various expansion units
- Remote control unit
- Connector cap BRA.0B.200.PCSG
- Connector cap BRA.1B.200.PCSG
- EXTERNAL I/O cable U-133
- 4109P-S32-7 (4-conductor shielded) N-129
- 4109P-S32-7 (6-conductor shielded) U-131
- 4109P-BNC plug U-132
- 4109P-BNC jack U-129
- 4109P-R05 jack U-134
- SD card 4GB

- SD card 16 GB RP-SDFC16SW1
- Dynamic Data Acquisition Software DCS-100A (Please use the latest version)

**[Strain/Voltage Unit CTRS-CDV010A Specifications]**

Item		Strain measurement	Voltage measurement
Channels		4	
Input Connector	Connector Shape	NDIS4109(Small round 9 pins) receptacle Model: EPRC07-RX9FNDIS	
	Compatible Plug	NDIS4109(Small round 9 pins) plug Model: EPRC07-P9MNDIS	
Measuring Targets		Strain gages*1 Strain-gage transducers	Voltage
Compatible Bridge Resistance		When bridge excitation is set to 2 V 120 to 1000 Ω When bridge excitation is set to 5 V 350 to 1000 Ω	-
Gage Factor		2.00 fixed	-
Bridge Excitation/Sensor Excitation		2, 5 VDC A maximum of 20 mA per channel can be output.	2, 5 VDC*2 OFF (0 V)
Input Impedance		-	3.6 MΩ±10%
Input Modes		Balanced differential input	
Measuring Range	Setting Method	Any range method or OFF	
	Settable Range	Minimum: 1000 × 10 <sup>-6</sup> strain Maximum: 50000 × 10 <sup>-6</sup> strain	Minimum: 1 V Maximum: 50 V
	Setting Steps	·1000 to 10000 × 10 <sup>-6</sup> strain 100 × 10 <sup>-6</sup> strain steps ·10000 to 50000 × 10 <sup>-6</sup> strain 1000 × 10 <sup>-6</sup> strain steps	·1 to 10V 0.1 V steps ·10 to 50 V 1 V steps
Range Accuracy		Within ±0.2% FS	
Nonlinearity		Within ±0.1% FS	

## [Strain/Voltage Unit CTRS-CDV010A Specifications]

Item		Strain measurement	Voltage measurement
Temperature Stability	Zero Point	Within $\pm(0.009\% \text{ FS} + 0.9 \times 10^{-6} \text{ strain})/^{\circ}\text{C}$	Within $\pm(0.009\% \text{ FS} + 0.21 \text{ mV})/^{\circ}\text{C}$
	Sensitivity	Within $\pm 0.03\%/^{\circ}\text{C}$	
Time Stability	Zero Point	Within $\pm(0.09\% \text{ FS} + 9 \times 10^{-6} \text{ strain})/8 \text{ h}$	Within $\pm(0.09\% \text{ FS} + 0.1 \text{ mV})/8 \text{ h}$
	Sensitivity	Within $\pm 0.3\%/8 \text{ h}$	
Balance Adjustment	Setting	For each channel, ON, OFF, or NONE can be selected. ON: Execute balance adjustment and set the measured value to zero. OFF: Do not execute balance adjustment again. NONE: Balance adjustment can be disabled to check the initial unbalanced value (Input voltage).	
	Operating Method	Execute the balance operation by using the control software <sup>3</sup> or operate the special-remote-control BAL switch.	
	Adjustment Method	Auto balance (Saved in nonvolatile memory)	
	Adjustment Range	Within $\pm 10000 \times 10^{-6} \text{ strain}$	Within $\pm 10 \text{ V}$
	Accuracy	Within $\pm (0.1\% \text{ FS} + 2 \times 10^{-6} \text{ strain})$	Within $\pm 0.1\% \text{ FS}$
	NONE Accuracy	Within $\pm 1\% \text{ FS}$ <sup>4</sup>	Within $\pm 0.2\% \text{ FS}$
Input Range		Within $\pm 60000 \times 10^{-6} \text{ strain}$	Within $\pm 60 \text{ V}$
Common-mode Input Voltage		-	Within $\pm 20 \text{ V}$
Absolute Maximum Rating	Input	$\pm 5 \text{ V}$	$\pm 70 \text{ V}$
Frequency Response		DC to 20 kHz, $-3 \pm 1 \text{ dB}$ (at 20 kHz)	
LPF	Transfer Characteristics	5th-order Butterworth	
	Cutoff Frequency	10, 20, 50, 100, 200, 500, 1k, 2k, 5k, 10k Hz as well as FLAT <sup>5</sup> , AUTO <sup>6</sup>	
	Amplitude Ratio at Cutoff Point	$-3 \pm 1 \text{ dB}$	
	Attenuation Characteristics	$-30 \pm 3 \text{ dB/oct.}$ <sup>7</sup>	
HPF	Cutoff Frequency	0.2, 1 Hz and OFF	
AD Conversion	Resolution	24 bits	
	Method	Synchronous sampling of all channels	
Indicator		Status LED, channel-status LED	
Other Functions	Input Resistance	Bridge resistance check function	
	Check Functions	Accuracy within $\pm 2\%$ Used for sensor connection checks	
	TEDS	Read the TEDS information and apply it to the measurement conditions. <sup>3</sup>	
Power Supply		Supplied by the CTRS-100A or CTRS-BATT010A	
Power Consumption		Approx. 2.1 W (When supplying 12 VDC)	
Operating Temperature		$-10$ to $50^{\circ}\text{C}$	
Operating Humidity		20 to 90% (Non-condensing)	
Storage Temperature		$-20$ to $60^{\circ}\text{C}$	
Vibration Resistance		49.0 m/s <sup>2</sup> (5 G), 5 to 200 Hz	
Shock Resistance		490 m/s <sup>2</sup> (50 G), 11 ms or less, half sine wave	
Dimensions		26.6 W $\times$ 92 H $\times$ 94 D mm (Excluding protrusions or protectors)	
Weight		Approx. 240 g	
Utility Nuts		Size: M4, 6 places	

\* The measuring unit specifications apply to the state in which the temperature has stabilized after a preheating time of 30 minutes.

\*1 A separate bridge box is necessary.

\*2 When the sensor excitation is 2 VDC, the positive side of the sensor excitation is + 1 V and the negative side is - 1 V.

When the sensor excitation is 5 VDC, the positive side of the sensor excitation is + 2.5 V and the negative side is - 2.5 V.

\*3 Only when online control is performed by a PC.

\*4 When the bridge resistance is 350  $\Omega$ .

\*5 When FLAT is set, the cutoff frequency is set to approx. 25 kHz.

However, the cutoff-point amplitude ratio specification is not applied.

\*6 When AUTO is set, the cutoff frequency is set to approx. 1/4 the specified sampling frequency.

\*7 Excluding cutoff frequencies over 5 kHz

### [Standard Accessories]

- Stack-connector cap (female)
- Stack-connector cap (male)
- Input connector caps x4

### [Optional Accessories]

- 4109P-S32-7 (4-conductor shielded) N-129
- 4109P-S32-7 (6-conductor shielded) U-131
- 4109P-BNC plug U-132
- 4109P-BNC jack U-129
- 4109P-R05 jack U-134

## [Thermocouple Unit CTRS-CTA010A Specifications]

Item		Details
Channels		4
Input Connector <sup>*1</sup>	Connector Shape	Push-in spring connection
	Connection Capacity	Conductor cross section solid / flexible 0.2 mm <sup>2</sup> ...1.5 mm <sup>2</sup> Conductor cross section AWG / kcmil 24...16 Stripping length 8 mm
Measuring Targets		Thermocouples
Measuring Targets <sup>*2</sup>		K, T, J, N
Measuring Range		K -200.0 to 1370.0 $^{\circ}\text{C}$ T -200.0 to 400.0 $^{\circ}\text{C}$ J -200.0 to 1200.0 $^{\circ}\text{C}$ N -200.0 to 1300.0 $^{\circ}\text{C}$
Resolution		0.1 $^{\circ}\text{C}$
Accuracy	External Reference Junction Compensator	Above -100 $^{\circ}\text{C}$ Within $\pm 0.1\%$ of reading $\pm 0.4^{\circ}\text{C}$ Below -100 $^{\circ}\text{C}$ Within $\pm 0.2\%$ of reading $\pm 0.6^{\circ}\text{C}$
	Internal Reference Junction Compensator	Ambient temperature 15 $^{\circ}\text{C}$ to 35 $^{\circ}\text{C}$ Above -100 $^{\circ}\text{C}$ Within $\pm 0.1\%$ of reading $\pm 1.4^{\circ}\text{C}$ Below -100 $^{\circ}\text{C}$ Within $\pm 0.2\%$ of reading $\pm 1.6^{\circ}\text{C}$ Ambient temperature -10 $^{\circ}\text{C}$ to 50 $^{\circ}\text{C}$ Above -100 $^{\circ}\text{C}$ Within $\pm 0.1\%$ of reading $\pm 2.4^{\circ}\text{C}$ Below -100 $^{\circ}\text{C}$ Within $\pm 0.2\%$ of reading $\pm 2.6^{\circ}\text{C}$
Sampling System		Scanning
Inside Sampling Frequencies		Approx. 0.5 Hz, approx. 2.0 Hz
Indicator		State indicator LED
Check Functions		Burnout check
Withstand Voltage		500VAC for 1min. between input and case (Output)
Power Supply		Supplied by the CTRS-100A or CTRS-BATT010A
Power Consumption		Approx. 0.7 W (When supplying 12 VDC)
Operating Temperature		$-10$ to $50^{\circ}\text{C}$
Operating Humidity		20 to 90% (Non-condensing)
Storage Temperature		$-20$ to $60^{\circ}\text{C}$
Vibration Resistance		49.0 m/s <sup>2</sup> (5 G), 5 to 200 Hz
Shock Resistance		490 m/s <sup>2</sup> (50 G), 11 ms or less, half sine wave
Dimensions		26.6 W $\times$ 92 H $\times$ 94 D mm (Excluding protrusions or protectors) 26.6 W $\times$ 92 H $\times$ 127 D mm (Excluding protrusions or protectors, including the temperature measuring adapter)
Weight		Approx. 240 g, not including the temperature measuring adapter Approx. 260 g, include the temperature measuring adapter
Utility Nuts		Size: M4, 6 places

\* The measuring unit specifications apply to the state in which the temperature has stabilized after a preheating time of 30 minutes.

### [Standard Accessories]

- Stack-connector cap (female)
- Stack-connector cap (male)
- Temperature measuring adapter CT-3A-4

### [Optional Accessories]

- Temperature measuring adapter CT-3A-4

## [Battery Unit CTRS-BATT010A Specifications]

Item		Details
Type of Battery		Lithium-ion battery United Nations Recommendations on the Transport of Dangerous Goods UN 38.3 safety tests: Passed The UN 38.3 safety test certification and a certificate of Safe Transport of Chemical Goods (Test Report) issued by the Shanghai Research Institute of Chemical Industry, China: Received
Input (DC IN)		10 to 30 VDC Connector: ECP.1S.302.CLL (LEMO) Compatible plug: FFA.1S.302.CLA** (LEMO) ** stands for the collet type, size number, etc.
Output		Voltage 10 VDC Current Maximum: 2.5 A (Ambient temperature: 0 to 40°C) Maximum: 1.5 A (Ambient temperature: -10 to 0°C) Maximum: 2.0 A (Ambient temperature: 40 to 50°C)
Operating Switch		Battery-check switch Press once : Remaining battery power check The battery-check LED indicates the remaining battery power. Hold down (For approx. one second) : Battery integrity check The battery-check LED indicates the integrity.
Indicator		Status LEDs 1 During external-power operation: lit up in blue During battery operation: lit up in purple (The LED flashes purple when the remaining battery power is less than 30%.) When an error occurs: flashes red Battery-check LEDs: 3 When checking the remaining battery power: ●/●/● 100 to 70% (Lit up in blue) ●/●/- 69 to 30% ●/-/- 29 to 0% * Flashes red at 5% or less When checking the integrity: ●/●/● Good (Lit up in purple) ●/●/- Caution ●/-/- Replacement required Flash red (all 3) When an error occurs: (● : Lit up, - : Off) Flash red (all 3)
Charging Time*1	When Charging the Battery Alone	4.5 h or less (Ambient temperature 10 to 40°C) 7.0 h or less (Ambient temperature 0 to 10°C)
	When Supplying Power to the System and Charging the Battery at the Same Time	7.0 h or less (Ambient temperature 10 to 40°C) 10.0 h or less (Ambient temperature 0 to 10°C) <sup>2</sup>
Discharge Time		During 2.5 A (25 W) output: 60 minutes or more During 0.5 A (5 W) output: 300 minutes or more * When using a new battery at an ambient temperature of 25 ±10°C (Reference) The power consumption of each unit is as follows: CTRS-100A 3.5 W CTRS-CDV010A 2.1 W CTRS-SYNC010A 0.3 W Because the total power consumption in the case of analog measurement on 32 channels + the use of synchronous unit is approx. 18.5 W, operation for 80 minutes or more is possible.
Operating Temperature	Charging	0 to 40°C
	Discharging	-10 to 50°C
Operating Humidity		20 to 90% (Non-condensing)
Storage Temperature		-20 to 50°C * In the case of long-term storage for one month or more, avoid high temperatures or humidity, and store the unit at 40°C or less.
Vibration Resistance		49.0 m/s <sup>2</sup> (5 G), 5 to 200 Hz
Shock Resistance		490 m/s <sup>2</sup> (50 G), 11 ms or less, half sine wave
Dimensions		53.2 W × 92 H × 94 D mm (Excluding protrusions or protectors)
Weight		Approx. 570 g
Utility Nuts		Size: M4, 12 places
Battery Pack Replacement		Handled by Kyowa (Replacement by the user is not possible.)

\*1 If the battery is hot, it may stop charging before it is fully charged for safety reasons. This is not a malfunction.

\*2 Depending on the environment, charging may stop before the battery is fully charged for safety reasons. This is not a malfunction.

### [Standard Accessories]

·Stack-connector cap (male)

### [Optional Accessories]

·CTRS AC adapter UIA345-12-L-JP (For U.S.A.: UN1345-1238-L-US) ·CTRS DC power cable P-79 ·Connector cap BRA.1B.200.PCSG

## [Synchronization Unit CTRS-SYNC010A Specifications]

Item		Details
Connector		Synchronous input connector Synchronous output connector
Indicator		Status LED REMOTE LED
Operating Switch	4-bit DIP Switch	ETHERNET-USB communication switch: 1 bit Device ID setting: 2 bits Reserved: 1 bit
Synchronous Operation Function	Number of Unit that Can Be Connected	A maximum of four units can be connected in a cascade by using synchronous cable.
	Recorded Data	Recorded data can be saved to the SD card for each CTRS-100A as a separate file or to a PC (Only when online control is performed by the PC).
Ethernet Communication		Communication is possible by connecting a communication cable. * Ethernet communication is possible at a distance of up to 52.8 m by extending the communication cable by using an RJ-45 relay connector (Kyowa recommended items) and LAN cable (Kyowa recommended items).
Distance between Devices		2 m or less
Power Supply		Supplied by the CTRS-100A or CTRS-BATT010A
Operating Temperature		-10 to 50°C
Operating Humidity		20 to 90% (Non-condensing)
Storage Temperature		-20 to 60°C
Vibration Resistance		49.0 m/s <sup>2</sup> (5 G), 5 to 200 Hz
Shock Resistance		490 m/s <sup>2</sup> (50 G), 11 ms or less, half sine wave
Power Consumption		Approx. 0.3 W
Dimensions		26.6 W × 92 H × 94 D mm (Excluding protrusions or protectors)
Weight		Approx. 200 g
Utility Nuts		Size: M4, 6 places

### [Standard Accessories]

·Stack-connector cap (female)  
·Stack-connector cap (male)

### [Optional Accessories]

·CTRS sync cable N-130 ·Connector cap BRA.1B.200.PCSG ·LAN cable 50m LD-CTTB500  
·CTRS communication cable N-131 ·LAN cable 20m NWYC5E-STP-S-BL-20 ·RJ-45 relay adapter ADT-EX-STPN

## [Wireless LAN Unit CTRS-WLAN010A/011A Specifications]

Item		Details	
Model		CTRS-WLAN010A	CTRS-WLAN011A
Supported Functions		Collection of collected data, Setting of measurement conditions, Real-time monitoring <sup>*1</sup>	
Operating Switch		"WIRELESS": Enables or disables the wireless LAN unit operation. "SETUP": Use the "Easy connection function" <sup>*2</sup> . "RESET": Reset SSID and security key to factory default.	
Indicator		Status LED Wireless LAN status LED (2.4 GHz and 5 GHz)	
Radio Section	Compliance Standards	IEEE 802.11 a/b/g/n/ac	
	Frequency	2.4 GHz and 5 GHz	
	Channel	2.4 GHz: 1 to 13 ch 5 GHz: 36, 40, 44, 48 ch (W52) <sup>*3</sup>	2.4 GHz: 1 to 11 ch 5 GHz: 36, 40, 44, 48 ch (W52) <sup>*3</sup> 149, 153, 157, 161, 165 ch (W58) <sup>*3</sup>
	Security	WPA2-PSK(AES) WPA-PSK(AUTO/TKIP) <sup>*4</sup> None	
	Network Type	Access point mode	
	Number of Simultaneous Connections to a PC	1	
	Antenna	Built-in antenna	
	Country <sup>*5</sup>	Japan	U.S.
Other Functions		Easy connection function DHCP server function <sup>*6</sup>	
Power Supply		Supplied by the CTRS-100A or CTRS-BATT010A	
Power Consumption		Approx. 2.0 W (When supplying 12 VDC)	
Operating Temperature		-10 to 50°C	
Operating Humidity		20 to 90% (Non-condensing)	
Storage Temperature		-20 to 60°C	
Vibration Resistance		49.0 m/s <sup>2</sup> (5 G), 5 to 200 Hz	
Shock Resistance		490 m/s <sup>2</sup> (50 G), 11 ms or less, half sine wave	
Dimensions		26.6 W × 92 H × 94 D mm (Excluding protrusions or protectors)	
Weight		Approx. 200 g	
Utility Nuts		Size: M4, 6 places	

\*1 Depending on the radio wave environment of the installation location, the monitor may stop due to a decrease in the transfer rate of wireless LAN communication.

\*2 Communicate with WPS (Wi-Fi Protected Setup) compatible devices and use wireless LAN Easy to configure complex security settings. (Equivalent to WPS 2.0)

\*3 5 GHz band is for indoor use only. (Do not use outdoors)

\*4 When WPA-PSK (AUTO/TKIP) is selected, the "Easy connection function" cannot be used.

[Standard Accessories]

\*5 Not available in other countries.

\*6 The IP address of the wireless connection device (PC) can be set automatically.

·Stack-connector cap (male) ·Stack-connector cap (female)

## [Remote Control Unit CTRS-RCU010A Specifications]

Item		Details	
Operating Button Switch	REC	Start recording. Operating method: Press the button once.	
	STOP	Stop recording. Operating method: Press the button once or twice. <sup>*1</sup>	
	BAL	Execute a balance operation. Operating method: Press the button twice or hold it down. <sup>*1</sup>	
	READ	Read the condition settings from the SD card. Operating method: Hold down the button.	
	OPTION 1, OPTION 2	Use the control software to assign any function to these buttons for use. Operating method: Press the button once. ·Monitor ·Delete the latest data file ·Over reset ·PAUSE	
Indicator		Status LED Remaining-battery-power indicator LED Remaining-SD-card-space indicator LED Range-over indicator LED REC LED BAL LED READ LED OPTION 1 LED OPTION 2 LED	
Other Functions		Built-in buzzer Strap hole	
Operating Temperature		-10 to 50°C	
Operating Humidity		20 to 90% (Non-condensing)	
Storage Temperature		-20 to 60°C	
Vibration Resistance		49.0 m/s <sup>2</sup> (5 G), 5 to 200 Hz	
Shock Resistance		490 m/s <sup>2</sup> (50 G), 11 ms or less, half sine wave	
Power Consumption		Approx. 0.2 W	
Dimensions		46 W × 90 H × 20 D mm (Excluding protrusions)	
Weight		Approx. 120 g	
Utility Nuts		Size: M3, 6 places	

\* Hold down: To press and hold down a button for at least one second. Press twice: To press a button switch twice within 0.5 seconds.

\*1 This can be switched by using the control software.

## [Dynamic Data Acquisition Software DCS-100A Specifications for control of CTRS-100A]

Item		Details	
Operating Environment	OS	Windows® 8.1 or Windows® 10, English/Japanese 32, 64 bits support	
	CPU	Core i5 2GHz or more	
	Memory	If 32-bit OS, 2 GB or more If 64-bit OS, 4 GB or more	
	Display	1024×768 pixels or more	
Main Functions		Y-time graphs display Real-time measurement Measurement condition setting TEDS information	

\* If you already have DCS-100A, just update your DCS-100A for using it.

# Dimensions

**Compact Recorder CTRS-100A**

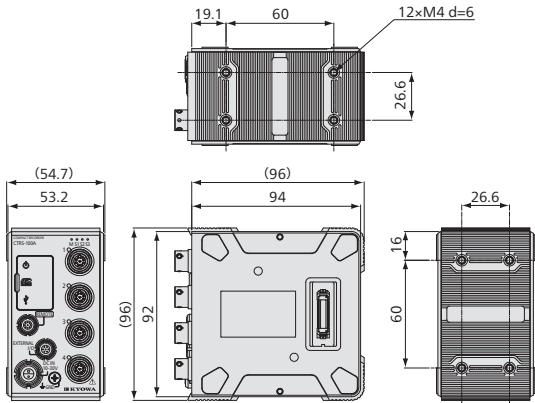

**Strain/Voltage Unit CTRS-CDV010A**

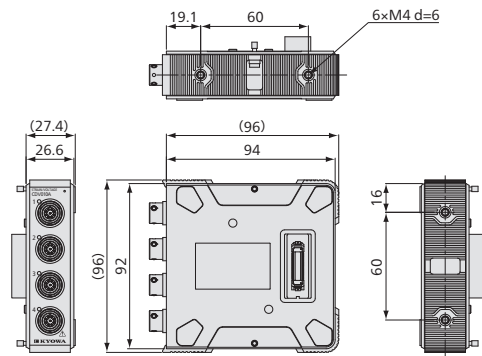

**Battery Unit CTRS-BATT010A**

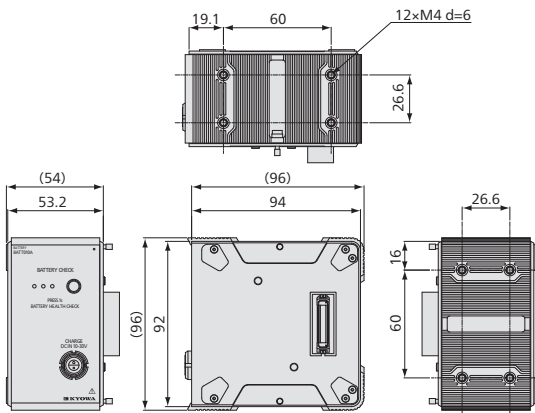

**Synchronization Unit CTRS-SYNC010A**

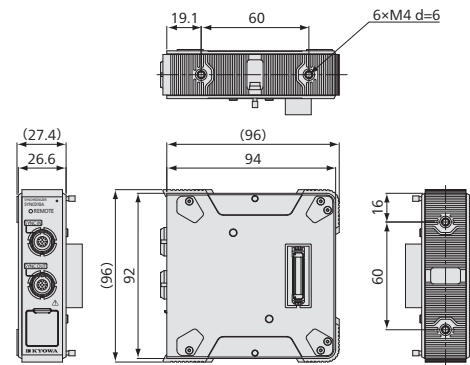

**Wireless LAN Unit CTRS-WLAN010A/011A\*1**

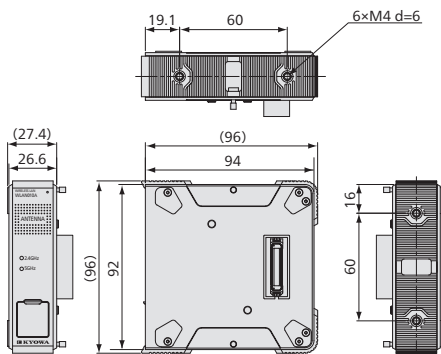

**Thermocouple Unit CTRS-CTA010A**

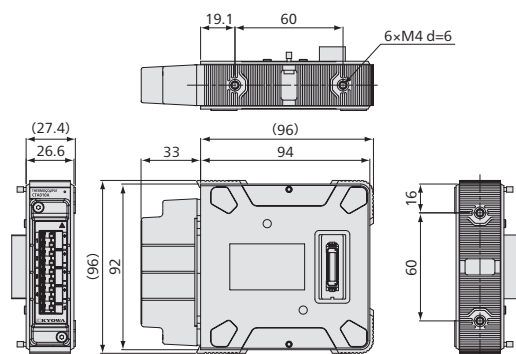

\*1 CTRS-WLAN011A is the same in dimensions.

**Remote Control Unit CTRS-RCU010A**

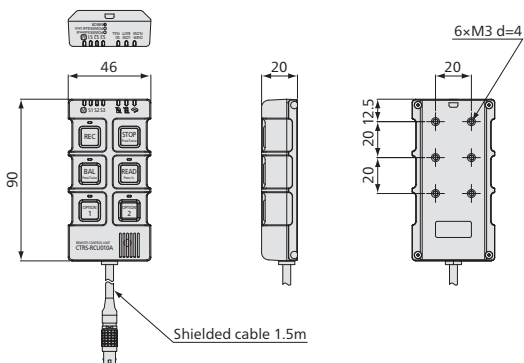

# You can count on Kyowa.

Feel free to contact us,  
if there is something you would like to know or  
do not understand about Kyowa products.



## Sales Network



### Other Countries or Regions

Please visit below URL.  
Website: [www.kyowa-ei.com](http://www.kyowa-ei.com)

### Americas Region

KYOWA AMERICAS, Inc.  
TEL: +1-248-348-0348  
E-mail: [sales@kyowa-americas.com](mailto:sales@kyowa-americas.com)  
Website: [www.kyowa-ei.us](http://www.kyowa-ei.us)

### China

KYOWA ELECTRONIC (SHANGHAI) TRADING CO., LTD.  
TEL: +86-21-6447-7770  
E-mail: [support-cn@d1.kyowa-ei.co.jp](mailto:support-cn@d1.kyowa-ei.co.jp)  
Website: [www.kyowa-ei.cn](http://www.kyowa-ei.cn)

### Thailand

KYOWA DENGYO (THAILAND) CO., LTD.  
TEL: +66-2-117-3760  
E-mail: [sales-thailand@kyowa-ei.co.th](mailto:sales-thailand@kyowa-ei.co.th)  
Website: [www.kyowa-ei.co.th](http://www.kyowa-ei.co.th)

### India

KYOWA ELECTRONIC INSTRUMENTS CO., LTD. (India Branch)  
TEL: +91-124-427-7227  
Website: [www.kyowa-ei.com](http://www.kyowa-ei.com)

## KYOWA ELECTRONIC INSTRUMENTS CO., LTD.

Overseas Sales Department:  
3-5-1, Chofugaoka, Chofu, Tokyo 182-8520 Japan  
TEL: +81-42-489-7220 FAX: +81-42-488-1122  
E-mail: [kyowaoverseas.hp@d1.kyowa-ei.co.jp](mailto:kyowaoverseas.hp@d1.kyowa-ei.co.jp)  
Website: [www.kyowa-ei.com](http://www.kyowa-ei.com)



### Safety Precautions

- Be sure to observe the safety precautions given in the instruction manual, in order to ensure correct and safe operation.
- Do not use in locations subject to significant water, dampness, steam, dust, or flammable gases.  
Doing so may lead to fire, electrical shock, or malfunction.

- Specifications and designs are subject to change without notice.
- Please contact us if using the detailed products for special applications.
- Detailed company and product names are the trademarks or registered trademarks of their respective owners.
- The warranty details can be found on the "Product Warranty" attached to the product and on the following website.  
[www.kyowa-ei.com/eng/company/quality/warranty.html](http://www.kyowa-ei.com/eng/company/quality/warranty.html)
- Unauthorized use or reproduction of contents of this catalog are prohibited.

