



INSTRUMENTS  
**TECHNO  
TEST**

# INSTRUCTION MANUAL

## RMH-310A

### DIGITAL STRAIN RECORDER

Thank you for purchasing KYOWA's product RMH-310A Digital Strain Recorder.

Read this Instruction Manual carefully in order to make full use of the high performance capabilities of the product.

Do not use the product in methods other than described in this Manual.

Windows are trademarks of Microsoft Corporation, U.S.A. and other countries.

Generally, company names and trade names described in this Instruction Manual are trademarks or registered trademarks of the companies.

This Instruction Manual may not be copied or reproduced, in whole or part, without consent of KYOWA.

Copyright © Kyowa Electronic Instruments Co., Ltd. All rights reserved.

The contents of the Instruction Manual and specifications of the software are subject to change without prior notice.

Kyowa Electronic Instruments Co., Ltd. assumes no liability for any damage resulting from the use of the software.

## CONTENTS

<b>STANDARD ACCESSORIES</b> .....	1
<b>OPTIONAL ACCESSORIES</b> .....	1
<b>SAFETY PRECAUTIONS (Do not forget to read the safety precautions prior to use.)</b> .....	2
<b>PRIOR TO USE</b> .....	2
<b>SAFETY SYMBOLS</b> .....	2
<b>NOTATIONS USED IN THE INSTRUCTION MANUAL</b> .....	5
<b>QUOTATIONS</b> .....	5
<b>INFORMATIONAL NOTES</b> .....	5
<b>IMPORTANT PRECAUTIONS WHEN USING RMH-310A</b> .....	5
<b>1 OUTLINE OF PRODUCT</b> .....	6
<b>1-1 OUTLINE OF PRODUCT</b> .....	6
<b>1-2 SYSTEM CONFIGURATION</b> .....	7
<b>2 CONTROLS AND INDICATORS</b> .....	8
<b>2-1 FRONT PANEL</b> .....	8
<b>3 HOW TO USE</b> .....	9
<b>3-1 OPERATION FLOW</b> .....	9
<b>3-2 OPERATING STATUS</b> .....	9
<b>3-3 OPERATION PROCEDURES</b> .....	10
<b>3-4 GROUNDING</b> .....	11
<b>4 CONNECTING</b> .....	12
<b>4-1 TO CONNECT THE POWER SUPPLY</b> .....	12
4-1-1 To open the battery cover .....	12
4-1-2 To connect cables .....	12
4-1-3 Pin assignment .....	12
<b>4-2 TO CONNECT STRAIN GAGE SENSORS</b> .....	13
<b>4-3 TO COMPENSATE TEMPERATURES OF TRANSDUCERS WITH TEMPERATURE MEASURING FUNCTIONS</b> .....	14
<b>4-4 TO CONNECT THERMOCOUPLES</b> .....	14
<b>4-5 TO SELECT BATTERIES</b> .....	16
<b>5 MENU LIST</b> .....	17
<b>6 SETTING CONDITIONS</b> .....	18
<b>6-1 TO SET CONDITIONS</b> .....	18
6-1-1 RMH-310A key operations .....	18
6-1-2 By loading the USB memory .....	18
<b>6-2 BASIC ITEMS</b> .....	19
<b>6-3 BASIC OPERATIONS</b> .....	20
6-3-1 Safety precautions .....	20
6-3-2 By loading the USB memory .....	21
<b>6-4 BY PRESSING RMH-310A KEYS</b> .....	23
6-4-1 To set the last channel No. .....	23
6-4-2 To set sensor names .....	25
6-4-3 To set titles .....	27
6-4-4 To set calibration constants .....	28
6-4-5 To set units .....	30
6-4-6 To set measuring point names .....	31
6-4-7 To set measuring modes .....	33
6-4-8 To set initial values .....	34
6-4-9 To measure initial values .....	36
6-4-10 To set RTD resistances .....	38
6-4-11 To set interval times .....	40

6-4-12 To set the number of measurements .....	42
<b>7 STARTING/STOPPING MEASUREMENTS.....</b>	<b>44</b>
<b>7-1 BASIC OPERATIONS .....</b>	<b>44</b>
7-1-1 To start interval measurements .....	44
7-1-2 To stop interval measurements .....	46
<b>8 RETRIEVING DATA.....</b>	<b>47</b>
<b>8-1 BASIC OPERATIONS .....</b>	<b>47</b>
<b>9 OTHER FUNCTIONS.....</b>	<b>50</b>
<b>9-1 REAL-TIME MONITOR FUNCTION .....</b>	<b>50</b>
<b>9-2 MAINTENANCE MENU .....</b>	<b>51</b>
9-2-1 To check conditions.....	51
9-2-2 Self-diagnosis function .....	52
9-2-3 To set the built-in clock.....	54
9-2-4 To retrieve backup data .....	56
9-2-5 To check versions.....	57
<b>10 TROUBLE SHOOTING .....</b>	<b>58</b>
<b>11 SPECIFICATIONS.....</b>	<b>61</b>
<b>11-1 OUTSIDE DRAWING .....</b>	<b>63</b>

## STANDARD ACCESSORIES

The following accessories are packed with the RMH-310A.

When unpacking, check the contents to ensure that all accessories are enclosed.

Read in the beginning	1	
Battery cable	1	
Warranty and Test Certificate	1 each	
USB memory(File system FAT 32)	1	
Supplementary tool (for converting data format and creating measuring conditions)	1 set	} *2
Instruction manual, specifications, outside drawing	1 set	

\*1 Check the expiration date of the backup battery, on the RMH-310A side panel.

Do not use the product after the expiration date. Or, it may cause data corruption or built-in clock to reset.

\*2 The supplementary tool and instruction manual are saved in the attached USB memory.

You are also able to download them from our website.

<http://www.kyowa-ei.com/>

## OPTIONAL ACCESSORIES

Battery	RB-5A (Ah, C size lithium battery×3) RB-10A (10Ah, C size lithium battery×6)
USB memory	The accessory USB memory is an industrial USB memory with extended temperature range. Some commercially available USB memories may not work due to incompatibility and temperature issues. For recommendations, contact Kyowa or our representatives. Format information: File system FAT 32, Allocation unit size 4096 bytes.

SAFETY PRECAUTIONS (Do not forget to read the safety precautions prior to use.)



PRIOR TO USE

For safe use of the product, do not forget to read the "Safety Precautions" prior to use.

Kyowa Electronic Instruments Co., Ltd. assumes no liability for any damage resulting from the user's failure to comply with the safety precautions.

SAFETY SYMBOLS

For safety operation of the product, the following symbol marks are used in the Instruction Manual.

 DANGER	Improper operation of the system will result in death or severe injury of the operator.
 WARNING	Improper operation of the system may result in death or severe injury of the operator.
 CAUTION	Improper operation of the system may result in injury of the operator and physical damage of the system.

 DANGER
<ul style="list-style-type: none"><li>● Do not short-circuit the positive (+) and negative (-) terminals of batteries. Or, it may generate heat or ignite due to excessive current.</li><li>● Do not heat or throw batteries into fire. Or, it may generate heat, ignite or explode.</li><li>● Connect the power connector properly. Or, it may generate heat or ignite due to excessive current.</li><li>● Do not charge the specified batteries (RB-5A, RB-10A). The batteries are not manufactured to allow charging. Or, it may cause explosion.</li></ul>

 WARNING

- To prevent a fire hazard, ensure that the power supply voltage specified for the product matches the local line voltage before connecting the system to the DC power.
- To prevent the risk of fire hazard or explosion, do not use the product in environment with inflammable gas, vapor, or dust.
- To prevent a fire hazard, if smoke is emitted from the product, immediately disconnect the adapter and stop using the product.
- Avoid measuring object applied with high voltage.  
Or, it may lower the performance and cause troubles.
- When the product is faulty, emitting smoke or offensive odor, or producing abnormal sound, immediately turn OFF the power.
- In case if any foreign matters or water are entered or the product is dropped, immediately turn OFF the power.
- Do not put liquid on the product.  
If the liquid is spilled into the product, it may cause trouble, fire hazard or explosion.
- Do not remodel the product.  
Or, it may cause explosion or fire hazard.
- When it started thundering, do not touch the product or cables.  
Or, it may cause electric shock.
- Place the product on a stable place.  
Or, the product may drop and damage surroundings.
- When using the product outdoors, store it in a waterproof case and securely fix it.  
Or, it may cause explosion, fire hazard, dropping and damaging surroundings.
- Do not charge the specified batteries (RB-5A, RB-10A).  
The batteries are not manufactured to allow charging.
- Do not disassemble the batteries.
- For input lightning surge protection, be sure to earth (ground) the ground terminal (S).
- Do not operate the product at a location with excessive vibration.

 CAUTION

- Before wiring, check the terminal array.
- Before moving the product, disconnect all cables.
- Use the product within temperature ranging from -20 to 50°C.  
Use at temperatures exceeding the specified range may lower the performance and cause trouble.  
If use under direct sunlight or in a cold place is inevitable, prepare a sunscreen or take proper measures to keep it warm.
- Use the product in the specified operating humidity range 10 to 95%RH.  
Use in a humid place exceeding the specified range or where it is exposed to splashing water may lower the performance and cause trouble.
- Do not use the product immediately after the change in the environment.  
Leave the product as it is until it becomes adaptable to the environment.  
Abrupt change in ambient temperature due to transportation, etc. may cause dew condensation, which may result in lower performance and troubles.
- Cover terminal blocks under dusty environment.  
Or, it may cause contact failure, insulation failure, and measurement errors. We recommend cleaning input terminals periodically.
- To prevent short-circuit trouble, fasten screws on a terminal block.
- Use the product under environment without excessive vibration or high impact.  
Or, it may cause trouble.
- Do not use the product in strong electromagnetic field.  
Use the product in a magnetic field environment where the PC may be used.  
Performance may be lowered and erroneous operation and troubles may result if it is used near a telemetry system, microwave oven, electronic furnace or any other equipment generating a strong magnetic field.
- Be sure to use the product within the specified power supply voltage range.  
6 to 15 VDC  
The power supply used for the product should not experience an instantaneous power failure and be free from noise.
- Do not pull cords and cables.  
Lay cords and cables with a certain allowance so that unreasonable force is not applied to the connections. Pulling or applying unreasonable force may cause trouble or interrupt the measurement.
- Do not disassemble or remodel the product. Or, it may cause electric shock or trouble.
- Do not insert foreign matters to USB connectors. Or, it may cause trouble.
- Use strain gage transducers (bridge resistance: 350 ohm). Or, it may cause measurement errors.
- Some commercially available USB memories may not work due to incompatibility and temperature issues. We recommend using the accessory USB memory or recommendations.
- Do not connect/disconnect the USB memory while retrieving data. Or, it may cause file system errors or bad sectors. The RMH-310A may not retrieve data due to file system errors or bad sectors.  
To fix file system errors or bad sectors, run an error check on the USB memory from the PC.  
Before using the USB memory, we recommend running an error check from the PC.
- The product keeps the measured data and operates the built-in clock by using the backup battery.  
After the expiration date has passed, contact Kyowa or our representatives. Our service center will replace the backup battery with a new one.

## NOTATIONS USED IN THE INSTRUCTION MANUAL

### QUOTATIONS

Names described on the panel surface are expressed in double quotation mark " ".

Example "SET" key

Items indicated on the menu are enclosed with [ ].

Example [Condition Settings]

### INFORMATIONAL NOTES

Certain notations are used as necessary to attract your attention to information that requires special care when handling the product, and to information provided for reference purposes.

#### Examples of Notations

##### NOTE

Essential precautions required when handling the product.

##### MEMO

Reference items required when handling the product.

### IMPORTANT PRECAUTIONS WHEN USING RMH-310A

##### NOTE

- 1 Do not connect/disconnect the USB memory while retrieving data.  
Or, the data in the USB memory or USB memory itself may be damaged.
- 2 Use the battery that has sufficient capacity. The current consumption is as follows.  
When in operation:           Approx. 100 mA  
When not in operation:       Approx. 100 $\mu$ A
- 3 Some commercially available USB memories may not work due to incompatibility and temperature issues.  
We recommend using the accessory USB memory or recommendations.

# 1 OUTLINE OF PRODUCT

## 1 - 1 OUTLINE OF PRODUCT

The RMH-310A is a battery-operated digital strain recorder featuring low power consumption.

The RMH-310A is suitable for unmanned, long-term measurement in remote places, mountainous regions and heavy snowfall districts where no power supply is available.

The RMH-310A measures 10-channel data by connecting strain gage civil engineering transducers, civil engineering transducers with temperature measuring function, strain gage transducers, and thermocouples (K-type and T-type).

The operation panel and display enable the user to set measuring conditions and perform measurement-related operation. The RMH-310A retrieves data by using the USB memory in binary format data files (.DA2) and text format files (.CSV).

Therefore, you are able to retrieve data on multiple sites easily, by using the USB memory only.

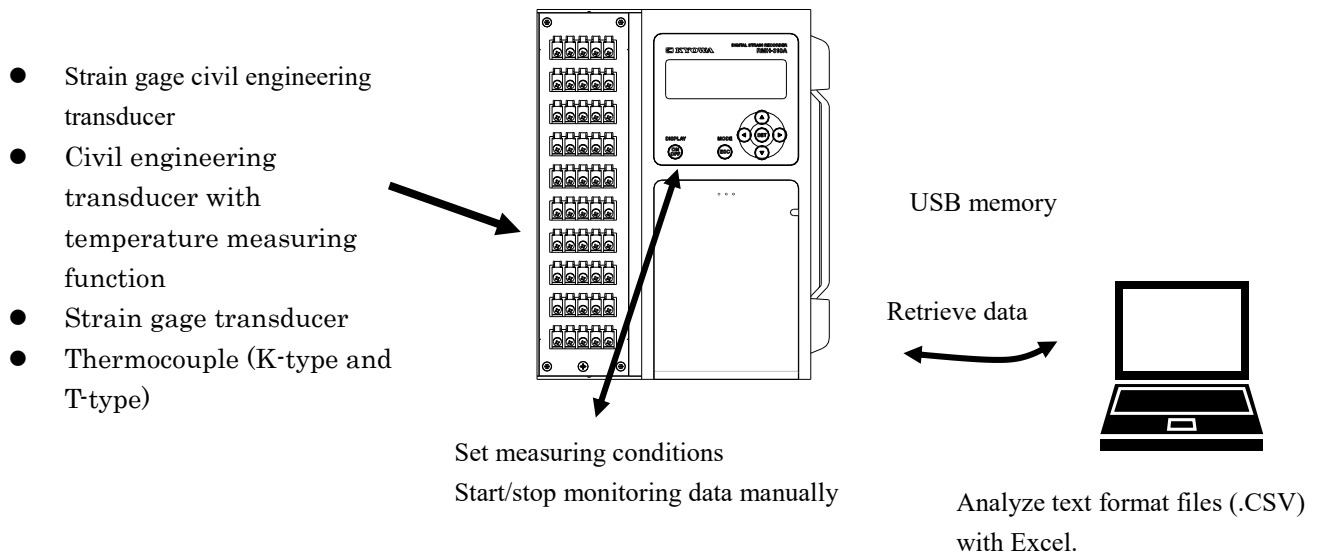

## 1 - 2 SYSTEM CONFIGURATION

Power supply	Use batteries (6 to 15 VDC). The current consumption is as follows. When in operation:       Approx. 100 mA When not in operation:    Approx. 100μA
USB memory	For retrieving data. We recommend using the accessory USB memory or recommendations.
PC	Make sure the PC has an USB interface for connecting the USB memory.

Input (sensor): 10 channels

- Strain gage civil engineering transducer (350 ohm)
- Civil engineering transducer with temperature measuring function (350 ohm)
- Strain gage transducer
- Thermocouple (K-type)
- Thermocouple (T-type)

For details, see “4 - 2 TO CONNECT STRAIN GAGE SENSORS.”

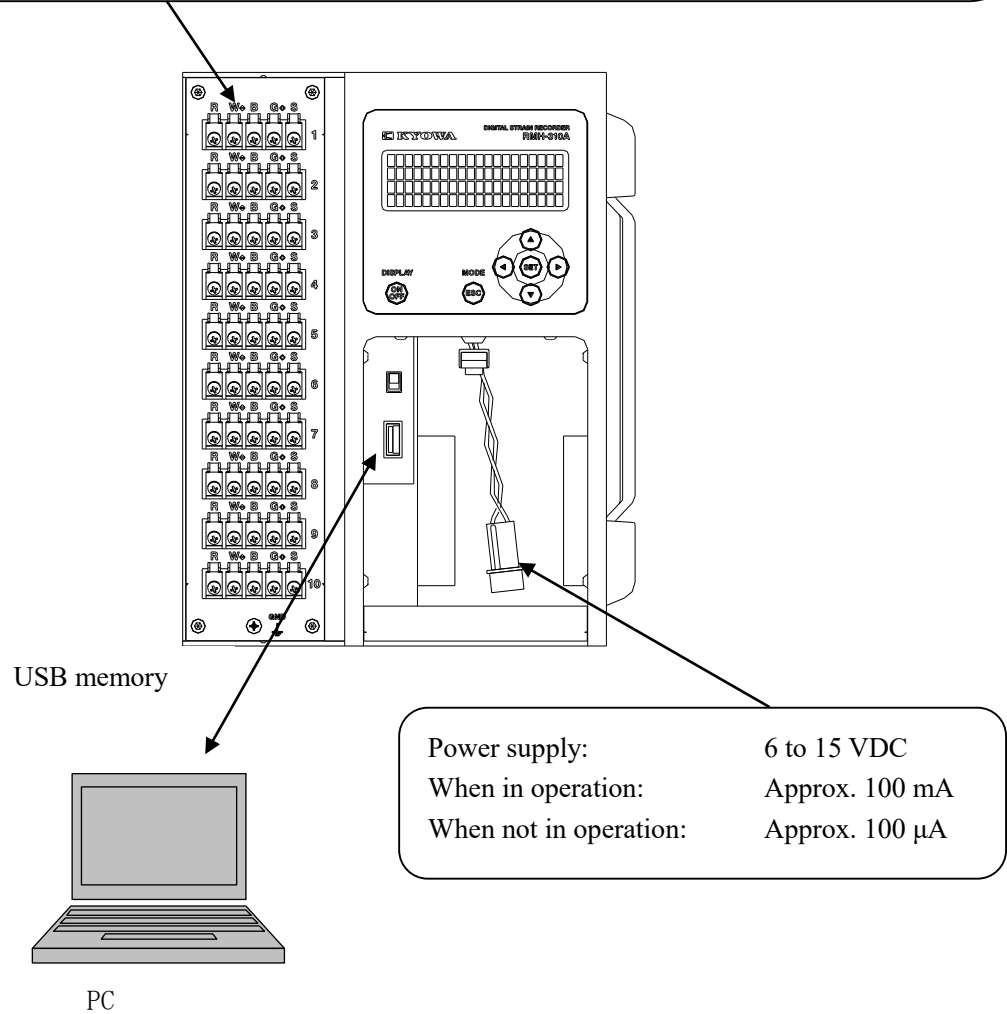

The above figure is the RMH-310A outside drawing without the battery cover.

## 2 CONTROLS AND INDICATORS

### 2-1 FRONT PANEL

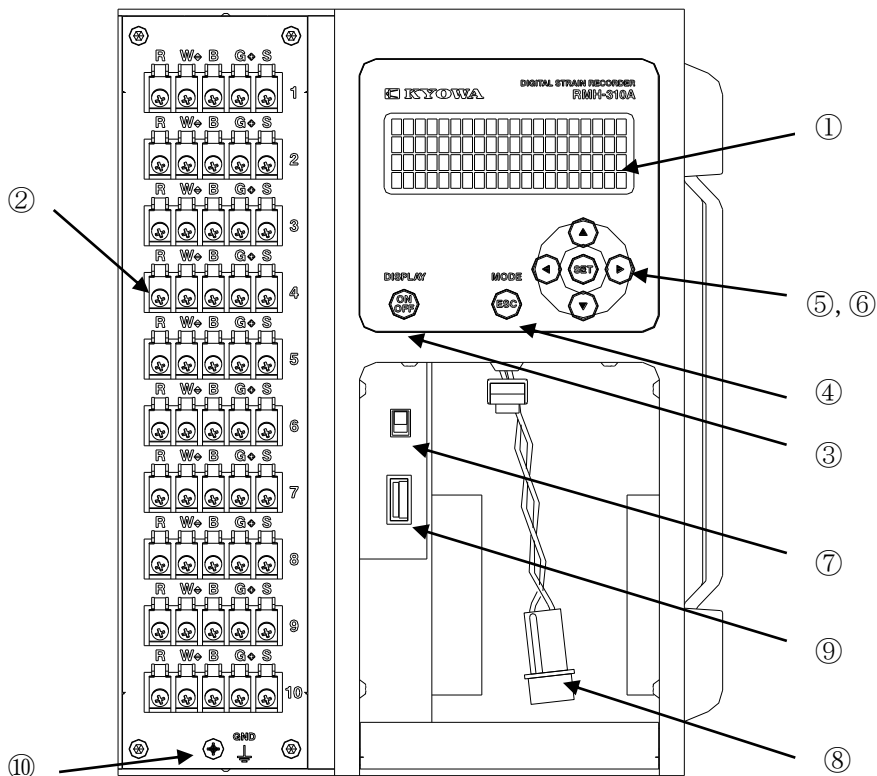

The above figure is the RMH-310A outside drawing without the terminal block cover and battery cover.

- |   |   |
|---|---|
| <ul style="list-style-type: none"> <li>① Display</li> <li>② Input terminal block</li> <li>③ “ON/OFF” key</li> <li>④ “ESC” key</li> <li>⑤ Operation keys: (&lt;, &gt;, ^, and v)</li> <li>⑥ “SET” key</li> <li>⑦ “POWER” switch</li> <li>⑧ POWER connector</li> <li>⑨ USB connector</li> <li>⑩ GND terminal</li> </ul> | <ul style="list-style-type: none"> <li>Connects sensors. (Soldering, screw-fixed terminal block, M3)<br/>Cover terminal blocks before measuring thermocouples.<br/>Leave the product as it is until the input terminal temperature is stable.<br/>Do not expose the product to air-conditioner wind or direct sunlight.</li> <li>Turns ON/OFF the display.</li> <li>Cancels the menu and changes the character mode.</li> <li>Selects a menu and changes the character or number.</li> <li>Determines the setting.</li> <li>“POWER” switch</li> <li>Connects the batteries.</li> <li>Connects the USB memory.<br/>Be aware of the orientation of the USB memory.</li> <li>GND terminal</li> </ul> |
|---|---|

#### MEMO

If you leave the RMH-310A for 2 minutes without a key operation, the RMH-310A will be POWER-OFF MODE.

### 3 HOW TO USE

#### 3-1 OPERATION FLOW

Operate the RMH-310A as follows.

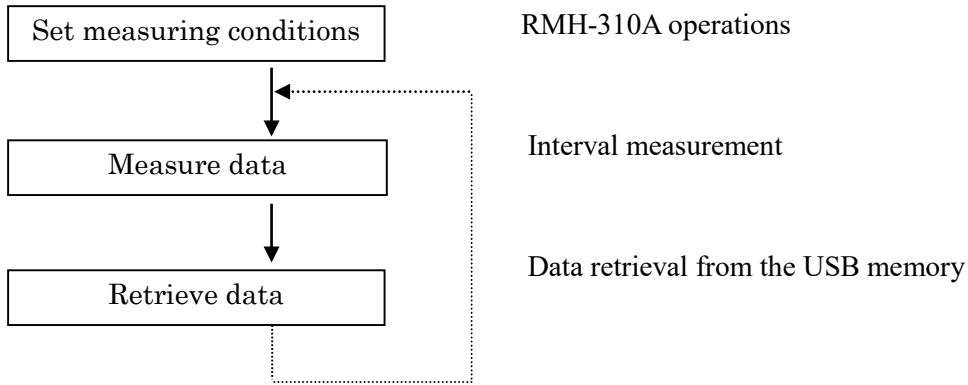

#### 3-2 OPERATING STATUS

The RMH-310A has 3 operating statuses as follows.

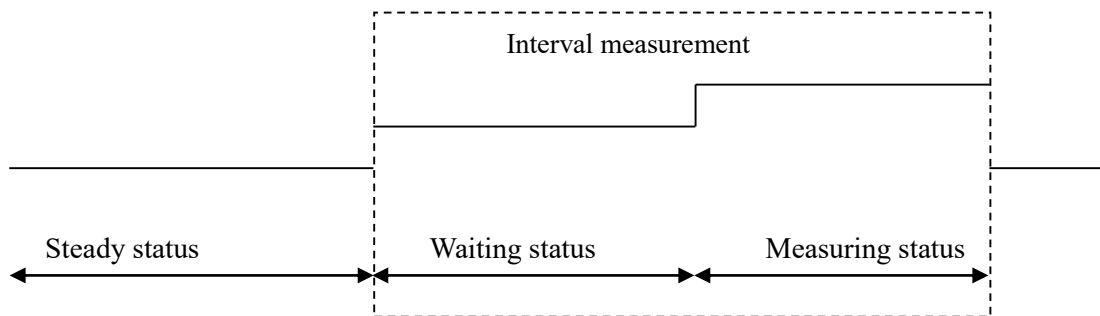

- Steady status      Not interval measurements.
- Waiting status      Not measuring data during interval measurements.
- Measuring status      Measuring data during interval measurements.

### 3 - 3 OPERATION PROCEDURES

This section describes necessary operations from installation to measurement.

Operate the RMH-310A as follows.

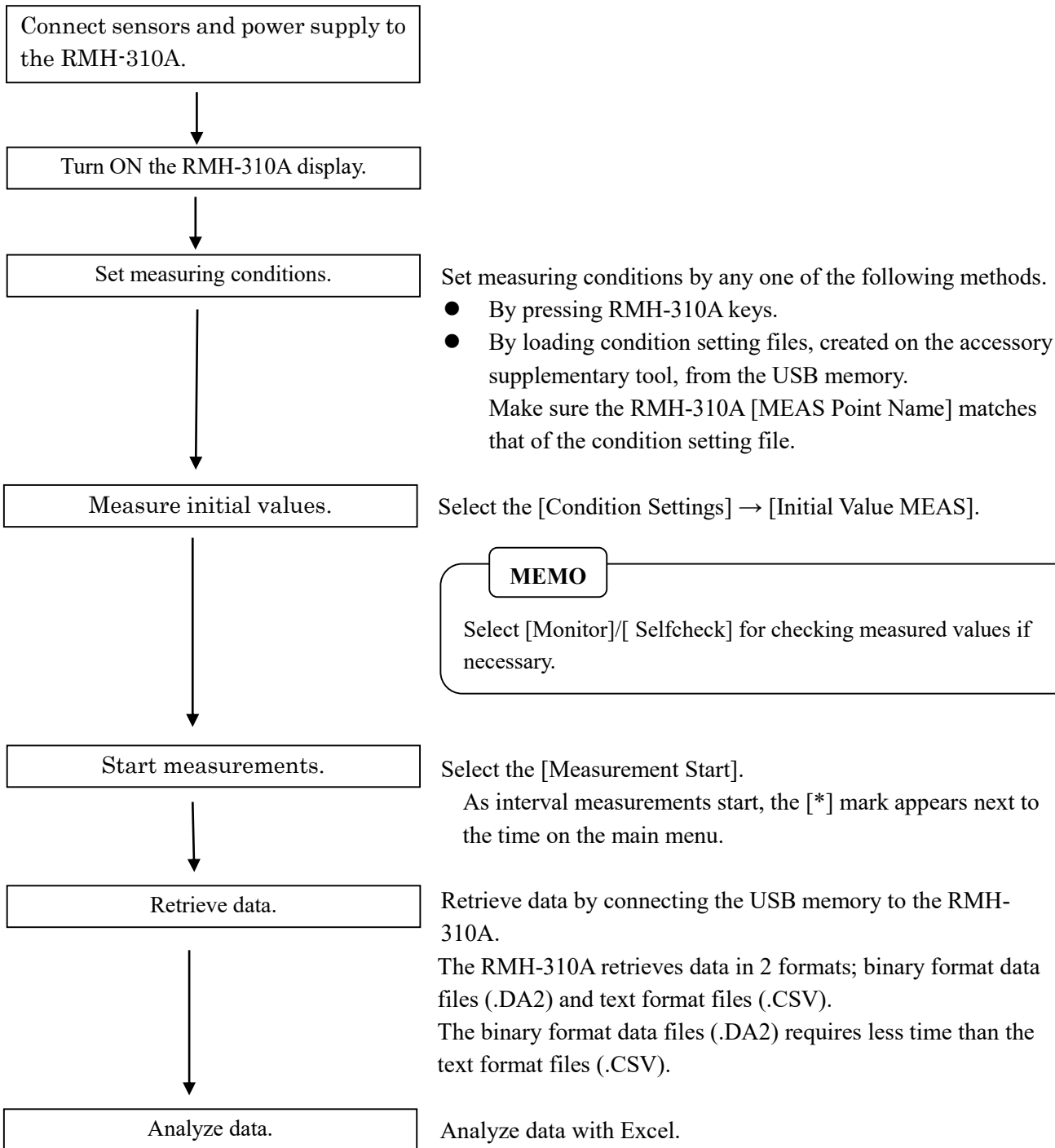

Text format files (.CSV)

Binary format data files (.DA2)

The RMH-310A loads data with Excel/Notepad.

The RMH-310A does not load data.

You are required to convert the binary format data files (.DA2) into the text format files (.CSV) on the accessory supplementary tool.

### 3-4 GROUNDING

Be sure to connect the GND terminal to the ground.

Be sure to use vinyl-coated cables (nominal cross section:  $0.75 \text{ mm}^2$ ).

(1) Example 1 When measuring target is grounded

After checking the measuring target (Specimen) is securely grounded, connect the GND terminal by referring to the following figure.

① Connect the measuring target (Specimen) to the RMH-310A GND terminal with the vinyl-coated cable.

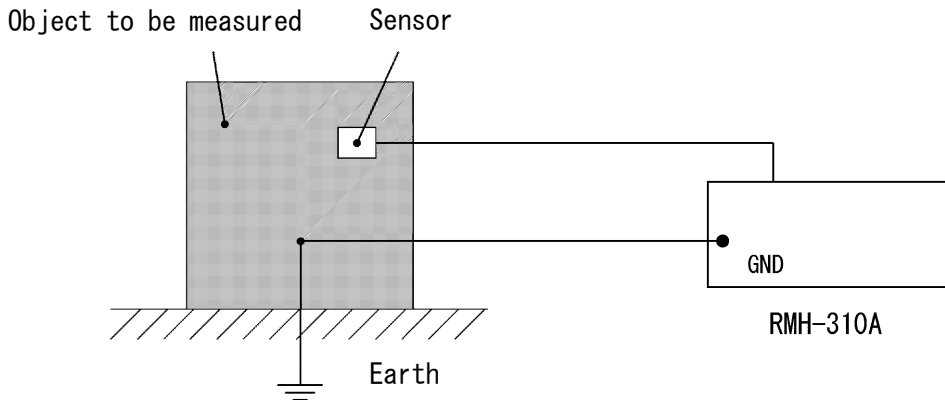

(2) Example 2 When measuring target is insulated from the earth

After checking the measuring target (Specimen) is securely insulated from the earth, connect the GND terminal by referring to the following figure.

① Connect the GND terminal of the RMH-310A and earth (ground) with the vinyl-coated cable.

② Connect the measuring target (Specimen) to the RMH-310A GND terminal with the vinyl-coated cable.

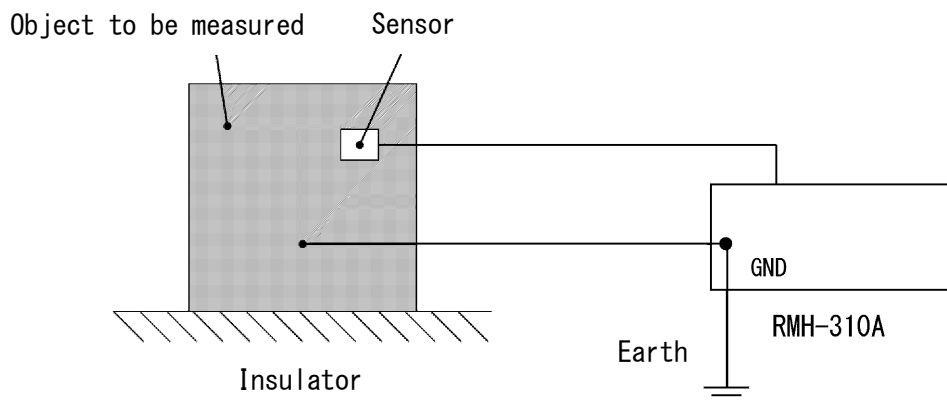

#### MEMO

The best approach varies with environmental conditions.

Try to connect GND terminals for decreasing noise and for stable measurements.

Basically single-point grounding is required.

Or, it may create loops and receive noise.

## 4 CONNECTING

### 4-1 TO CONNECT THE POWER SUPPLY

△ The RMH-310A power supply is 6 to 15 VDC.

#### 4-1-1 To open the battery cover

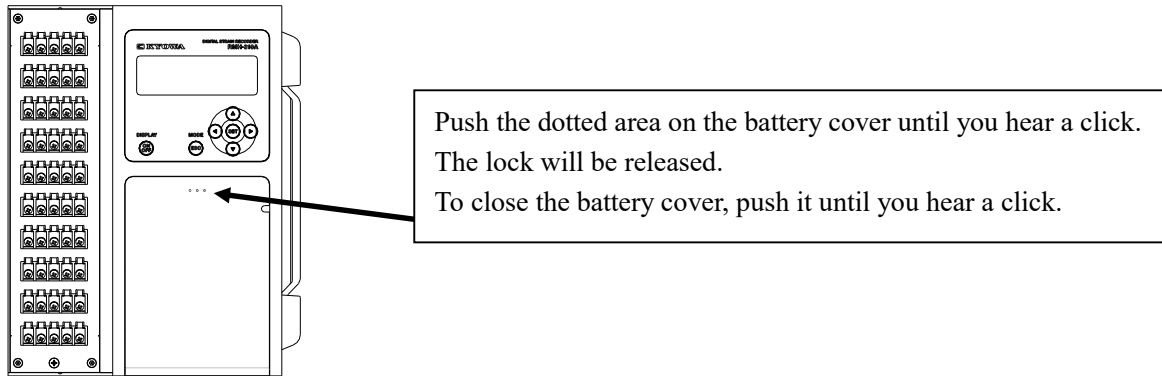

#### 4-1-2 To connect cables

Connect the power supply (6 to 15 VDC) to the POWER connector.

Red wire: +

Black wire: -

#### 4-1-3 Pin assignment

RMH-310A connector                      1-480319-0 (Tyco Electronics Japan G.K.)

Cable connector                              1-480318-0 (Tyco Electronics Japan G.K.)

Pin No.	Wire color	Signal content
1	Red	6 to 15 VDC
2	Black	GND

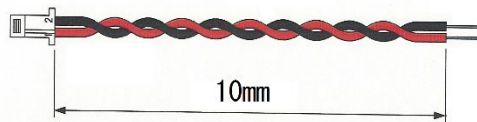

Accessory battery cable (outside drawing)

#### NOTE

- Connect the power connector properly.
- Do not disassemble the batteries. Or, it may cause accidents.
- Do not damage or short-circuit the batteries.
- Before connecting the power supply, check the power supply voltage (6 to 15 VDC).
- Do not connect the power supply reversed or supply excessive voltage.  
Or, the product may be damaged.

## 4-2 TO CONNECT STRAIN GAGE SENSORS

Connect a strain gage transducer or civil engineering transducer with temperature measuring function.

- Bared at the tip: Use screws or solder.  
 Solderless terminal: Use the 1.25-M3 or equivalent.  
 (Cable colors are Kyowa's standard color codes.)

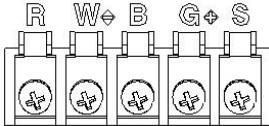

Terminal	Signal content
R	Red wire (Bridge excitation +)
W	White wire (Bridge output -)
B	Black wire (Bridge excitation -)
G	Green wire (Bridge output +)
S	Shield wire (Isolated from common mode signal and GND.)

Connector plug (PRC03-12A10-7M10.5):

Use the following input cable.

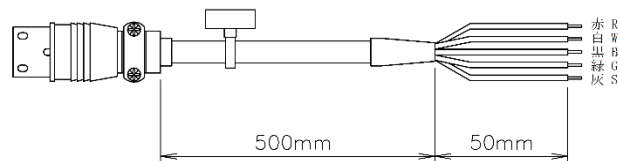

U-115 input cable

### NOTE

- Use strain gage transducers (bridge resistance: 350 ohm) and civil engineering transducers with temperature measuring function (bridge resistance: 350 ohm).  
Or, it may cause measurement errors.
- Locate the product far apart from power lines and wirings interfered with noise.
- When using the product under vibration, lay cords and cables with a certain allowance so that unreasonable force is not applied to the connections.  
Fix cables to keep them from moving due to vibration.  
Pulling or applying unreasonable force may cause trouble or interrupt the measurement.
- When the bridge excitation line of a sensor has a temperature property compensating resistor, the RMH-310A will not compensate the temperature property.

### 4 - 3 TO COMPENSATE TEMPERATURES OF TRANSDUCERS WITH TEMPERATURE MEASURING FUNCTIONS

The RMH-310A output temperature data based on an ideal Resistance Temperature Detector (RTD). However, the actual RTD has some errors. You are required to compensate temperature data as follows.

[Compensation formula]

$$\text{RMH-310A temperature} - (\text{So} - 10000) \times \beta = \text{Actual temperature}$$

(So: Zero-point,  $\beta$ : Temperature coefficient)

[Example]

Test Data Sheet                      So: 10205×0.01 ohm  
 Test Data Sheet                       $\beta$ : 0.0257°C/0.01 ohm  
 RMH-310A temperature:    20°C

Substitute the values into the compensation formula.

$$20^\circ\text{C} - (10205 - 10000) \times 0.0257 = 14.7^\circ\text{C}$$

The actual temperature is 14.7°C.

### 4 - 4 TO CONNECT THERMOCOUPLES

Connect thermocouples (K-type) as follows.

(Cable colors are Kyowa's standard color codes.)

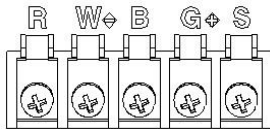

Terminal	Signal content
R	Not connected
W	White wire (Thermocouple -)
B	Not connected
G	Red/green wire (Thermocouple +)
S	Shield wire

Connect thermocouples (T-type) as follows.

(Cable colors are Kyowa's standard color codes.)

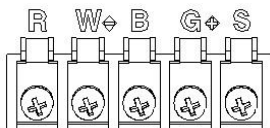

Terminal	Signal content
R	Not connected
W	White wire (Thermocouple -)
B	Not connected
G	Red/ brown (Thermocouple +)
S	Shield wire

**NOTE**

- Use K-type thermocouples and T-type thermocouples.  
Or, it may cause measurement errors.
- When using the product under vibration, lay cords and cables with a certain allowance so that unreasonable force is not applied to the connections.  
Fix cables to keep them from moving due to vibration.  
Pulling or applying unreasonable force may cause trouble or interrupt the measurement.
- Leave the product as it is until the input terminal temperature is stable.  
Cover terminal blocks before measuring thermocouples.  
Do not expose the product to air-conditioner wind or direct sunlight.  
Or, it may cause temperature errors.
- Place the product on a stable place.  
Or, it may cause temperature errors.
- Locate the product far apart from power lines and wirings interfered with noise.
- Use shielded twisted-pair cables for connecting thermocouples.  
Or, it may cause temperature errors.
- Do not directly connect thermocouples to the measuring target having potential larger than the ground.  
Or, it may cause trouble or temperature errors.

**MEMO**

When measured values are unstable, connect the RMH-310A GND terminal to the ground.

#### 4 – 5 TO SELECT BATTERIES

The RMH-310A uses batteries effectively since the RMH-310A turns ON the power during the measuring status and does not apply electric current during the waiting status.

The battery life varies with the type and ambient temperature.

You are able to calculate battery capacities as follows.

Note that the current consumption will not decrease significantly as you reduce the number of channels.

When in operation:	Approx. 100 mA
When not in operation:	Approx. 100μA

[Example 1]

The number of channels	10
Interval time	2 hours
Measuring time	12 months

You are able to calculate power consumptions (Ah) as follows.

$$\begin{aligned} & (\text{Power consumption when in operation} + \text{Power consumption when not in operation}) \div \text{Safety factor} \\ &= (0.1 \text{ A} \times 40 \text{ sec.} / 3600 \text{ sec.} \times 12 \text{ times} \times 30 \text{ days} \times 12 \text{ months} + 0.0001 \text{ A} \times 24 \text{ hours} \times 30 \text{ days} \times 12 \\ & \text{months}) \div \text{Safety factor} \\ &= (4.8 + 0.864) \div \text{Safety factor} \\ &= 5.664 \div \text{Safety factor (Ah)} \end{aligned}$$

Suppose the safety factor is 0.7, select 8.0914 (Ah) or larger.

[Example 2]

The number of channels	8
Interval time	1 hours
Measuring time	6 months

You are able to calculate power consumptions (Ah) as follows.

$$\begin{aligned} & (\text{Power consumption when in operation} + \text{Power consumption when not in operation}) \div \text{Safety factor} \\ &= (0.1 \text{ A} \times 40 \text{ sec.} / 3600 \text{ sec.} \times 24 \text{ times} \times 30 \text{ days} \times 6 \text{ months} + 0.0001 \text{ A} \times 24 \text{ hours} \times 30 \text{ days} \times 6 \text{ months}) \div \\ & \text{Safety factor} \\ &= (4.8 + 0.617) \div \text{Safety factor} \\ &= 5.417 \div \text{Safety factor (Ah)} \end{aligned}$$

Suppose the safety factor is 0.7, select 7.739 (Ah) or larger.

#### NOTE

~Safety factor~

Small self-discharge batteries (including lithium batteries)                      Safety factor: 0.7 to 0.8  
(The RB-5A and RB-10A are lithium batteries.)

Large self-discharge batteries (including lead storage batteries)                      Safety factor: 0.4 to 0.5

Charge rechargeable batteries every 6 months.

When the operating temperature is not ambient temperature (25°C) or using the batteries for a long time, lower the safety factor.

## 5 MENU LIST

The RMH-310A has the following menus.

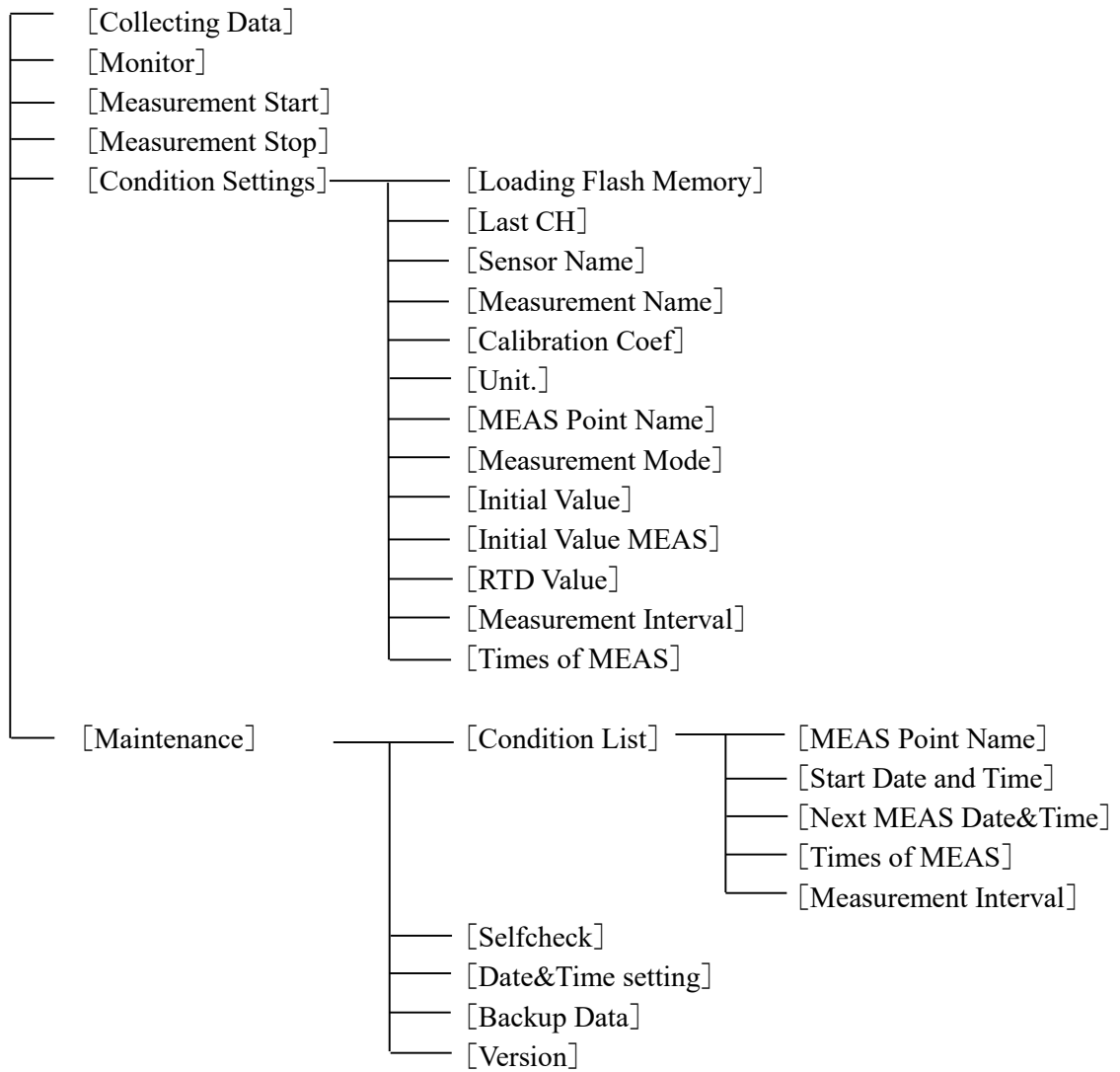

## 6 SETTING CONDITIONS

### 6-1 TO SET CONDITIONS

Set measuring conditions by any one of the following methods.

- By pressing RMH-310A keys.
- By loading condition setting files, created on the accessory supplementary tool, from the USB memory.

For supplementary tool, see separate volume of "RMH-310A DIGITAL STRAIN RECORDER INSTRUCTION MANUAL (SUPPLEMENTARY TOOL)".

#### 6-1-1 RMH-310A key operations

For details, see "6-4 BY PRESSING RMH-310A KEYS."

#### 6-1-2 By loading the USB memory

- (1) Connect the USB memory into the USB connector on the PC.
- (2) Save the measuring conditions on the USB memory by using the supplementary tool.  
For supplementary tool, see separate volume of "RMH-310A DIGITAL STRAIN RECORDER INSTRUCTION MANUAL (SUPPLEMENTARY TOOL)".
- (3) Disconnect the USB memory from the PC.
- (4) Connect the USB memory into the RMH-310A.
- (5) Load the measuring conditions on the RMH-310A.

For details, see "6-3-2 By loading the USB memory."

#### NOTE

- To set measuring conditions by loading the USB memory, use the supplementary tool. The supplementary tool is saved in the attached USB memory.
- To set measuring conditions by loading the USB memory, make sure the RMH-310A [MEAS Point Name] matches that of the condition setting file.

\* [MEAS Point Name] = Measuring point name = Measuring-point No.

## 6-2 BASIC ITEMS

The RMH-310A has the following basic items.

Item	Setting contents	Operation keys	Reference
Loading USB	To load condition setting files, created on the accessory supplementary tool, from the USB memory.	Condition Settings → Loading Flash Memory	6-3-2
Last channel No.	To set the number of channels.	Condition Settings → Last CH	6-4-1
Sensor name	To set sensor names.	Condition Settings → Sensor Name	6-4-2
Title	To set titles.	Condition Settings → Measurement Name	6-4-3
Calibration constant	To save calibration constants for converting measured values into physical quantities.	Condition Settings → Calibration Coef	6-4-4
Unit	To save units of physical quantities.	Condition Settings → Unit	6-4-5
Measuring point name	To set measuring point names for identifying units.	Condition Settings → MEAS Point Name	6-4-6
Measuring mode	To set measuring modes.	Condition Settings → Measurement Mode	6-4-7
Initial value	To set initial values.	Condition Settings → Initial Value	6-4-8
		Condition Settings → Initial Value MEAS	6-4-9
RTD resistance	To save resistances of civil engineering transducers with temperature measuring function at 0°C.	Condition Settings → RTD Value	6-4-10
Interval time	To set interval times during automatic measurements.	Condition Settings → Measurement Interval	6-4-11
The number of measurements	To set the number of measurements during automatic measurements.	Condition Settings → Times of MEAS	6-4-12

## 6 – 3 BASIC OPERATIONS

### 6-3-1 Safety precautions

#### NOTE

You are not able to change conditions during measurements.

When you select a sub-item on the [Condition Settings] menu, the following error message appears.

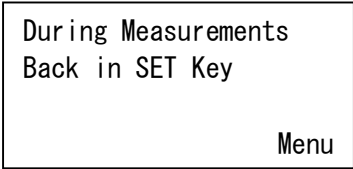
A rectangular box with a thin black border containing the text "During Measurements", "Back in SET Key", and "Menu" arranged vertically.

During Measurements  
Back in SET Key  
Menu

To cancel, press the “SET” key.

Before changing conditions, make sure the RMH-310A is stopped.

### 6-3-2 By loading the USB memory

Load condition setting files, created on the accessory supplementary tool, from the USB memory. For supplementary tool, see separate volume of "RMH-310A DIGITAL STRAIN RECORDER INSTRUCTION MANUAL (SUPPLEMENTARY TOOL)".

(1) To startup the supplementary tool

Startup the supplementary tool.

(2) To save the measuring conditions on the USB memory

- ① Connect the USB memory into the USB connector on the PC.
- ② Save the measuring conditions according to windows.
- ③ Disconnect the USB memory from the PC.

(3) To load measuring conditions on the RMH-310A.

- ① Connect the USB memory into the RMH-310A.
- ② Turn ON the RMH-310A display.  
Select the [Condition Settings] → [Loading Flash Memory].  
The RMH-310A starts loading measuring conditions.  
The following message appears.

Loading  
Condition File

[NOTE] You are not able to cancel the operation while loading measuring conditions.

- ③ As the RMH-310A completes loading, the following message appears.  
Press the "SET" key to go back to the previous menu.

Complete  
the setting  
Back in SET Key  
Menu

(4) To turn OFF the RMH-310A display

- ① Disconnect the USB memory.  
Turn OFF the RMH-310A display.

**NOTE**

- When condition setting files have an error, the following error message appears.

Input Value Err  
Back in SET Key  
Menu

Press the “SET” key to go back to the previous menu.

Note that the RMH-310A sets all items (excluding the error items) while loading data.

When the measurement start time is the current time or has passed, the above error message also appears.

- When the USB memory is not connected, the following message appears.

No Flash Memory  
Back in SET Key  
Menu

Press the “SET” key to go back to the previous menu.

Connect the USB memory.

Load the USB memory again.

Note that the above error message appears when the USB memory is not able to be loaded due to the incompatibility and failure.

- When the RMH-310A [MEAS Point Name] does not match that of the condition setting file, the following error message appears.

No Setting File  
Back in SET Key  
Menu

Press the “SET” key to go back to the previous menu.

Make sure the RMH-310A [MEAS Point Name] matches that of the condition setting file.

Load the USB memory again.

For details, see “6-4-6 To set measuring point names.”

- When the following messages appear, format the USB memory on the PC.

Memory Unavailable  
Back in SET Key  
Menu

Format Err  
Back in SET Key  
Menu

When the same messages appear, you are not able to use the USB memory.

Use other USB memories.



②After the completion, the following message appears.

Saved Settings Back in SET Key  <u>Menu</u>
--

③Press the “SET” key to go back to the [Measurement Name] menu.

**NOTE**

The RMH-310A measures continuous channel No. from CH01.

[Example]

Suppose the last channel No. is [5].

The RMH-310A measures the CH01 to CH05.

You are not able to skip any channels.



(3) Press the “SET” key to complete settings.

① As you press the “SET” key, the following message appears.

```
Save Settings?  
Select    < > Key  
  
Y/N
```

② Move the cursor by pressing the “<” key and “>” key.

Press the “SET” key for determination.

To save settings: [Y]

To go back to the [Sensor Name] menu: [N]

After the completion, the following message appears.

Press the “SET” key to set the next channel.

```
Saved Settings  
Next CH in SET Key  
  
Next
```

```
Sensor Name    ABC  
Character Change ESC  
2ch  
abcdefg
```

③ After setting all channels, press the “SET” key to go back to the [Sensor Name] menu.

```
Saved Settings  
Back in SET Key  
  
Menu
```

### 6-4-3 To set titles

This section describes how to enter titles.

(1) Select the [Condition Settings] → [Measurement Name].

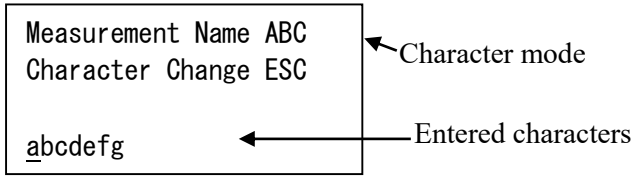

(2) Enter titles.

Range: 20

Key operations and available characters are the same as that of the sensor names.

(3) Press the “SET” key to complete settings.

① As you press the “SET” key, the following message appears.

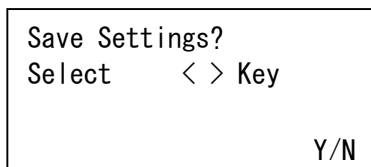

② Move the cursor by pressing the “<” key and “>” key.

Press the “SET” key for determination.

To save settings: [Y]

To go back to the [Measurement Name] menu: [N]

After the completion, the following message appears.

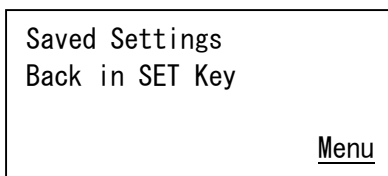

③ Press the “SET” key to go back to the [Measurement Name] menu.

#### 6-4-4 To set calibration constants

This section describes how to enter calibration constants.

The calibration constants on this section are just notes.

Note that the RMH-310A will not monitor/save measured values based on the notes.

You are able to use the notes during data procession, after retrieving data.

(1) Select the [Condition Settings] → [Calibration Coef].

```
Calibration Coef
Value Change Up&Down
1ch
                000001.234
```

Enter calibration constants.

Range: 10

To move the cursor “<”key and “>” key

To select numbers “^” key and “v” key

#### NOTE

Available characters are described as follows.

- Numbers 0 to 9
- Symbols +, -, .

(3) Press the “SET” key to complete settings.

① As you press the “SET” key, the following message appears.

```
Save Settings?
Select < > Key
                Y/N
```

② Move the cursor by pressing the “<” key and “>” key.

Press the “SET” key for determination.

To save settings: [Y]

To set the next channel: [N]

After the completion, the following message appears.

```
Save Settings?
Select < > Key
                Y/N
```

When the RMH-310A is not able to recognize numbers, the following error message appears.

Press the “SET” key to go back to the [Calibration Coef] menu.

```
Input Value Err
Back in SET Key
                Return
```

- ③ After the completion, the following message appears.

Press the “SET” key to set the next channel.

```
Saved Settings
Next CH in SET Key

Next
```

```
Calibration Coef
Value Change Up&Down
2ch

000001.234
```

- ④ After setting all channels, press the “SET” key to go back to the [Calibration Coef] menu.

```
Saved Settings
Back in SET Key

Menu
```

**NOTE**

When the RMH-310A is not able to recognize numbers, the following error message appears.

```
Input Value Err
Return
```

Press the “SET” key to go back to the [Calibration Coef] menu.

Re-enter the values.

The calibration constants on this section are just notes.

Note that the RMH-310A will not monitor/save measured values based on the notes.

You are able to use the notes during data procession, after retrieving data.

### 6-4-5 To set units

This section describes how to enter units.

The items on this section are just notes.

Note that the RMH-310A will monitor/save measured values in  $\mu\text{m}/\text{m}$ .

You are able to use the notes during data procession, after retrieving data.

(1) Select the [Condition Settings] → [Unit.].

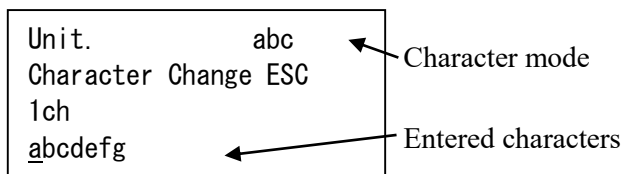

(2) Enter units.

Range: 8

Key operations and available characters are the same as that of the sensor names.

(3) Press the “SET” key to complete settings.

① As you press the “SET” key, the following message appears.

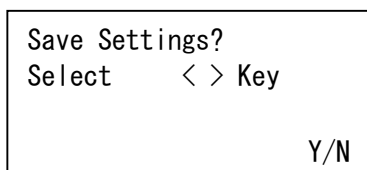

② Move the cursor by pressing the “<” key and “>” key.

Press the “SET” key for determination.

To save settings: [Y]

To go back to the [Unit] menu: [N]

After the completion, the following message appears.

Press the “SET” key to set the next channel.

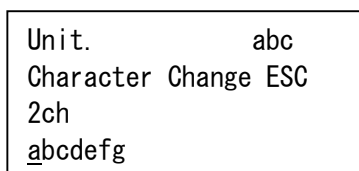
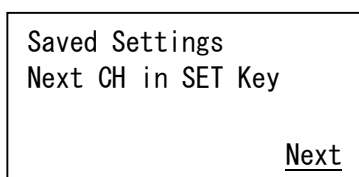

③ After setting all channels, press the “SET” key to go back to the [Unit] menu.

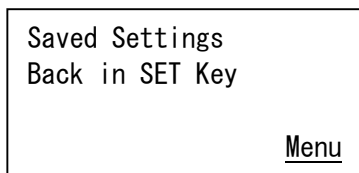

## 6-4-6 To set measuring point names

This section describes how to enter measuring point names.

The measuring point names are designed for identifying units.

When using the USB memory, the RMH-310A uses them as apart of file names.

The RMH-310A also uses the measuring point names as the [MEAS Point Name] for loading the condition setting files from the USB memory.

(1) Select the [Condition Settings] → [MEAS Point Name].

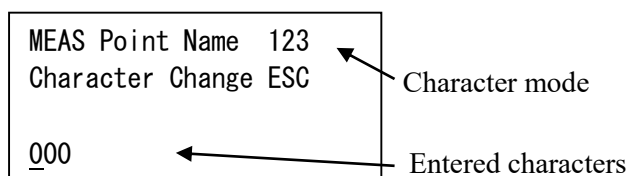

(2) Enter measuring point names.

Range: 3

Key operations and available characters are the same as that of the sensor names.

When the RMH-310A [MEAS Point Name] does not match that of the condition setting file, the [No Setting File] appears.

### NOTE

Available characters are described as follows.

- Alphabet (uppercase letter)      A to Z      Mode: ABC
- Alphabet (lowercase letter)      a to z      Mode: abc
- Numbers      0 to 9      Mode: 123
- Katakana (half width)      ア to ヲ, ッ, °      Mode: アイウ

You are not able to use the following characters.

(ア, イ, ウ, エ, オ, ヲ, ッ, ヤ, ャ, ュ, ヨ, ヲ)

The diacritical marks dakuten and handakuten are treated as separate characters.

(3) Press the “SET” key to complete settings.

① As you press the “SET” key, the following message appears.

Save Settings? Select < > Key  Y/N
---

② Move the cursor by pressing the “<” key and “>” key.

Press the “SET” key for determination.

To save settings: [Y]

To go back to the [MEAS Point Name] menu: [N]

After the completion, the following message appears.

Saved Settings Back in SET Key  <u>Menu</u>
--

③ Press the “SET” key to go back to the [MEAS Point Name] menu.

6-4-7 To set measuring modes

This section describes how to set measuring modes. The RMH-310A has the following 5 modes.

- Strain mode [Strain]
- Temperature (RTD) mode [Temperature(RTD)]
- Strain + temperature (RTD) mode [Strain + Temperature]
- K-type thermocouple mode [Temperature(K)]
- T-type thermocouple mode [Temperature(T)]

(1) Select the [Condition Settings] → [Measurement Mode].

```

Measurement Mode
Select    < > Key
1ch
                                Strain
    
```

(2) Select the measuring mode.

Move the cursor by pressing the “<” key and “>” key.

The measuring mode changes as follows.

[Strain] → [Temperature(RTD)] → [Strain + Temperature] → [Temperature(K)] → [Temperature(T)]

(3) Press the “SET” key to complete settings.

① As you press the “SET” key, the following message appears.

```

Save Settings?
Select    < > Key
                                Y/N
    
```

② Move the cursor by pressing the “<” key and “>” key.

Press the “SET” key for determination.

To save settings: [Y]

To set the next channel: [N]

After the completion, the following message appears.

Press the “SET” key to set the next channel.

```

Saved Settings
Next CH in SET Key
                                Next
    
```

```

Measurement Mode
Select    < > Key
2ch
                                Strain
    
```

③ After setting all channels, press the “SET” key to go back to the [Measurement Mode] menu.

```

Saved Settings
Back in SET Key
                                Menu
    
```

### 6-4-8 To set initial values

This section describes how to set arbitrary initial values.

Before displaying/saving values, the RMH-310A subtracts the initial values from the measured values.

(1) Select the [Condition Settings] → [Initial Value].

```
Initial Value
Value Change Up&Down
1ch
                                012345
```

(2) Enter initial values.

Range: -32767 to 32767

To move the cursor “<”key and “>” key

To select numbers “^” key and “v” key

#### NOTE

Available characters are described as follows.

- Numbers: 0 to 9
- Symbols: -

To subtract: Add anything in front of initial values.

To add: Add - (minus) in front of initial values.

(3) Press the “SET” key to complete settings.

① As you press the “SET” key, the following message appears.

```
Saved Settings
Next CH in SET Key
                                Next
```

② Move the cursor by pressing the “<” key and “>” key.

Press the “SET” key for determination.

To save settings: [Y]

To set the next channel: [N]

After the completion, the following message appears.

After the completion, the following message appears.

Press the “SET” key to set the next channel.

```
Saved Settings
Next CH in SET Key
                                Next
```

```
Initial Value
Value Change Up&Down
2ch
                                012345
```

- ③ After setting all channels, press the “SET” key to go back to the [Initial Value] menu.

Saved Settings  
Back in SET Key  
Menu

**NOTE**

When the RMH-310A is not able to recognize numbers or when the initial values exceed its range, the following error message appears.

Input Value Err  
Back in SET Key  
Return

(The RMH-310A is not able to recognize numbers)

Setting Range Err  
Back in SET Key  
Return

(The initial values exceed its range)

Press the “SET” key to go back to the [Initial Value] menu.

Re-enter the values.

**NOTE**

~Measuring range and initial value range~

- Measuring range      Strain:  $\pm 20000 \mu\text{m/m}$
- Initial value range    -32767 to 32767

When the strain or initial value exceeds its range, the measured value will be 999999.

[Example] Strain: 20000, Initial value: 20000 → Indicating value: 00000

\* The RMH-310A subtracts initial values.

[Example] Strain: 20000, Initial value: 30000 → Indicating value: -10000

[Example] Strain: 25000, Initial value: 00000 → Indicating value: 999999

[Example] Strain: 00000, Initial value: 35000 → Indicating value: 999999

\* Actually you are not able to enter the initial value.

### 6-4-9 To measure initial values

This section describes how to measure initial values.

Before displaying/saving values, the RMH-310A subtracts the initial values from the measured values.  
The RMH-310A saves the measured value as the initial value.

(1) Select the [Condition Settings] → [Initial Value MEAS].

(2) Measure initial values.

The following message appears.

Move the cursor by pressing the “<” key and “>” key.

Press the “SET” key for determination.

```
MEAS Initial Value?
Select   < > Key
1ch
                                     Y/N
```

To measure initial values: [Y]

To measure the next channel: [N]

As the RMH-310A completes measurements, the initial value appears.

```
Initial Value
1ch
                                     12345
```

(3) Press the “SET” key to complete settings.

① As you press the “SET” key, the following message appears.

```
Failed to Measure
Next CH in SET Key
                                     Next
```

② Move the cursor by pressing the “<” key and “>” key.

Press the “SET” key for determination.

To save settings: [Y]

To measure the next channel: [N]

After the completion, the following message appears.

```
Save Settings?
Select   < > Key
                                     Y/N
```

- ③ Press the “SET” key to measure the next channel.

Saved Settings  
Next CH in SET Key  
  
Next

MEAS Initial Value  
Select < > Key  
2ch  
  
Y/N

Initial Value  
  
2ch  
  
12345

- ④ After setting all channels, press the “SET” key to go back to the [MEAS Initial Value] menu.

Saved Settings  
Back in SET Key  
  
Menu

#### MEMO

##### How to use initial values

- ① Suppose the load is 1000  $\mu\text{m}/\text{m}$  when installing a sensor.
- ② Measure an initial value.  
The RMH-310A saves the initial value (1000  $\mu\text{m}/\text{m}$ ).  
The indicating value and measured value become 0  $\mu\text{m}/\text{m}$ .
- ③ After interval measurements  
Before displaying/saving values, the RMH-310A subtracts the initial values from the measured values.  
This procedure helps you to know the changes intuitively.

You are also able to use this procedures for subtracting the ZERO balance of sensors.  
When you enter the initial values manually (see 6-4-8 To set initial values), note that the RMH-310A subtracts the entered initial values.

6-4-10 To set RTD resistances

This section describes how to save RTD resistances.

The items on this section are just notes.

Note that the RMH-310A will not monitor/save measured values based on the notes.

After retrieving data, compensate temperature.

For details, see “ 4 - 3 TO COMPENSATE TEMPERATURES OF TRANSDUCERS WITH TEMPERATURE MEASURING FUNCTIONS.”

(1) Select the [Condition Settings] → [RTD Value].

```

RTD Value
Value Change Up&Down
1ch
                                100.00
    
```

(2) Enter the RTD resistances at 0°C.

Range      Integral: 3 digits (including symbols)

            Decimal: 2 digits

To move the cursor    “<”key and “>” key

To select numbers     “^” key and “v” key

**NOTE**

Available characters are described as follows.

- Numbers: 0 to 9
- Symbols: +, .

(3) Press the “SET” key to complete settings.

① As you press the “SET” key, the following message appears.

```

Save Settings?
Select      < > Key
                                Y/N
    
```

② Move the cursor by pressing the “<” key and “>” key.

Press the “SET” key for determination.

To save settings:            [Y]

To set the next channel:    [N]

After the completion, the following message appears.

```

Saved Settings
Next CH in SET Key
                                Next
    
```

```

RTD Value
Value Change Up&Down
2ch
                                100.00
    
```

- ③ After setting all channels, press the “SET” key to go back to the [RTD Value] menu.

Saved Settings  
Back in SET Key  
Menu

**NOTE**

When the RMH-310A is not able to recognize numbers, the following error message appears.

Input Value Err  
Back in SET Key  
Return

Press the “SET” key to go back to the [RTD Value] menu.  
Re-enter the values.



**NOTE**

When the interval times are 00:00, error message appears.

Setting Range Err  
Back in SET Key

Return

Press the “SET” key to go back to the [Measurement Interval] menu.  
Re-enter the values.



**NOTE**

When the entered characters exceed the range, error message appears.

Saved Settings  
Back in SET Key

Menu

Press the “SET” key to go back to the [Times of MEAS] menu.

Re-enter the values.

## 7 STARTING/STOPPING MEASUREMENTS

### 7-1 BASIC OPERATIONS

7-1-1 To start interval measurements

(1) Select the [Measurement Start] on the main menu.

(2) Enter measurement start times.

Start Date and Time Value Change Up&Down  'YY/MM/DD hh:mm
--

To move the cursor

“<”key and “>” key

The cursor moves Year/Month/Day/Hour/Minute.

To increase numbers

“^” key

To decrease numbers

“v” key

(3) Press the “SET” key to go back to the [Measurement Mode] menu.

① As you press the “SET” key, the following message appears.

② The [Measurement Start] menu appears.

Measure has Start Back in SET Key  <u>Menu</u>
---

As interval measurements start, the [\*] mark appears next to the time on the main menu.

**NOTE**

- When the RMH-310A has data, the following message appears.  
Move the cursor by pressing the “<” key and “>” key.  
Press the “SET” key for determination.

There is Data.  
Or Delete?  
  
Y/N

To clear data and go back to the [Date&Time setting] menu: [Y]  
To go back to the [Measurement Start] menu: [N]

- When the RMH-310A is measuring data, the following message appears.  
Press the “SET” key to go back to the [Measurement Start] menu.

During Measurements  
Back in SET Key  
  
Menu

- When the measurement start time is the current time or has passed, the following error message appears.  
Press the “SET” key to go back to the [Date&Time setting] menu.

Time has Passed  
Back in SET Key  
  
Return

- When the measurement start time does not exist (example: June, 31), the following error message appears.  
Press the “SET” key to go back to the [Date&Time setting] menu.

Date Invalid  
Back in SET Key  
  
Return

7-1-2 To stop interval measurements

(1) Select the [Measurement Start] on the main menu.

② The following message appears.

Move the cursor by pressing the “<” key and “>” key.

Press the “SET” key for determination.

```
Measurement Stop?
Select    < > Key
                                     Y/N
```

To stop measuring data: [Y]

To go back to the [Measurement Stop] menu: [N]

(3) The following message appears.

```
Measurement Stop
Back in SET Key
                                     Menu
```

(4) Press the “SET” key to go back to the [Measurement Stop] menu.

As interval measurements stop, the [\*] mark disappears next to the time on the main menu.

**NOTE**

When the RMH-310A is already stopped, the following message appears.

Press the “SET” key to go back to the [Measurement Stop] menu.

```
Measurement Stopped
Back in SET Key
                                     Menu
```

## 8 RETRIEVING DATA

### 8-1 BASIC OPERATIONS

This section describes how to retrieve data on site, by using the USB memory.

The RMH-310A retrieves data in 2 formats; binary format data files (.DA2) and text format files (.CSV).

The RMH-310A has the largest current consumption when retrieving data.

Before retrieving data, make sure the RMH-310A battery has the enough voltage and current-carrying capacity. Or, the RMH-310A will be turned OFF.

(1) Connect the USB memory into the RMH-310A.

(2) Turn ON the RMH-310A display.

(3) Retrieve data.

- ① Select the [Data Collection] on the main menu.
- ② The following message appears.  
Select the CSV/BINARY.  
Press the “SET” key for determination.

Please Select Format  
Select < > Key

CSV/BINARY

Press the “ESC” key to go back to the [Data Collection] menu.

- ③ As the RMH-310A starts retrieving data, the following message appears.

Collecting Data  
50%

- ④ As the RMH-310A completes retrieving data, the following message appears.  
Press the “SET” key to go back to the [Collecting Data] menu.

Data Collection  
is Complete  
Back in SET Key

Menu

MMDDpppa.txt  
Create the Above?

Y/N

MEMO

- Data file names are specified as shown below.
  - Text format files (.CSV): *YYMMppp.txt*
  - Binary format data files (.DA2): *YYMMppp.r01*  
(*YY*: Created year, *MM*: Created month, *ppp*: Measuring point name)
- When the USB memory has same name files, you are able to save every file by suffixing [a] to [z] at the end of every file name.

MMDDpppa.txt  
Create the Above?  
  
Y/N

Cannot Created at  
Same Name File  
  
Menu

Move the cursor by pressing the “<” key and “>” key.

Press the “SET” key for determination.

To retrieve data and save it with the specified file name: [Y]

To go back to the [Data Collection] menu: [N]

After pressing the [N], the following error message appears.

Press the “SET” key to go back to the [Data Collection] menu.

The RMH-310A will not retrieve data.

- File format and time required for retrieving data

The binary format data files (.DA2) requires less time than the text format files (.CSV).

Text format files (.CSV)           The RMH-310A loads data with Excel/Notepad.

Binary format data files (.DA2)   The RMH-310A does not load data.

You are required to convert the binary format data files (.DA2) into the text format files (.CSV) on the accessory supplementary tool.

For supplementary tool, see separate volume of "RMH-310A DIGITAL STRAIN RECORDER INSTRUCTION MANUAL (SUPPLEMENTARY TOOL)".

Suppose the RMH-310A measures max. 32000 data.

The time required for retrieving data is as follows.

Binary format data files (.DA2):       Approx. 17 minutes

Text format files (.CSV):                Approx. 56 minutes

The text format files (.CSV) requires much time than the binary format data files (.DA2) since the RMH-310A makes the CPU speed slow to prioritize the low power consumption and long-term measurement.

- Retrieving data and current consumption

The RMH-310A has the largest current consumption when retrieving data.

Before retrieving data, make sure the RMH-310A battery has the enough voltage and current-carrying capacity. Or, the RMH-310A will be turned OFF.

When the RMH-310A is turned OFF, the RMH-310A retrieves data incorrectly and create 0 kB file on the USB memory. Note that the RMH-310A still saves the measured data.

However, a power supply interruption while retrieving data may damage the RMH-310A and USB memory.

**NOTE**

- When the RMH-310A has no data, the following error message appears.  
Press the “SET” key to go back to the [Data Collection] menu.

There is No Data  
Back in SET Key  
Menu

- When the USB memory is not connected, the following message appears.

No Flash Memory  
Back in SET Key  
Menu

Press the “SET” key to go back to the [Data Collection] menu.  
Note that the RMH-310A will not retrieve data with the error message.  
Press the “SET” key to go back to the [Data Collection] menu.  
Retrieve data again.

- When the USB memory does not have the free space for the data file, the following error message appears.

Capacity Shortage  
Back in SET Key  
Menu

Press the “SET” key to go back to the [Data Collection] menu.  
Delete unnecessary files in the USB memory. Retrieve data again.

- When the following messages appear, format the USB memory on the PC.

Memory Unavailable  
Back in SET Key  
Menu

Format Err  
Back in SET Key  
Menu

When the same messages appear, you are not able to use the USB memory.  
Use other USB memories.

- When retrieving data by using the USB memory from the RMH-310A stored in cold environment below 0°C, always preheat the RMH-310A for several minutes and connect the USB memory for retrieving data.  
Some commercially available USB memories may not work due to temperature issues.  
(The accessory USB memory is able to be used above -20°C.)

## 9 OTHER FUNCTIONS

### 9-1 REAL-TIME MONITOR FUNCTION

The real-time monitor function checks measured values, based on the current RMH-310A conditions. As the real-time monitor function starts, the RMH-310A will update measured values every 12 seconds. The real-time monitor function keeps updating measured values until pressing the “SET” key or “ESC” or keeps updating measured values for 2 minutes until entering the POWER-OFF MODE. The real-time monitor function will not save measured data. You are able to check current measured values by using the real-time monitor function during interval measurements (waiting status only).

(1) Select the [Monitor] on the main menu.

The RMH-310A executes sensor checkings first. The sensor checking results appear for several seconds.

[OK]: Passed

[NG]: Error

To cancel the real-time monitor function, press the “SET” key or “ESC” key.

SENSOR >		SENSOR <	
1ch OK	4ch OK	7ch OK	10ch OK
2ch OK	5ch OK	8ch OK	
3ch OK	6ch OK	9ch OK	

Then, the RMH-310A executes the real-time monitor function. Measured values appear regardless of the sensor checking results.

① Measuring mode: Strain

Monitor >	Monitor < >	Monitor <
1ch 12345 $\mu \epsilon$	7ch 12345 $\mu \epsilon$	10ch 12345 $\mu \epsilon$
2ch 12345 $\mu \epsilon$	8ch 12345 $\mu \epsilon$	
3ch 12345 $\mu \epsilon$	9ch 12345 $\mu \epsilon$	

② Measuring mode: Temperature (RTD) mode, K-type thermocouple mode, T-type thermocouple mode

Monitor >	Monitor < >	Monitor <
1ch 12.3 °C	7ch 12.3 °C	10ch 12.3 °C
2ch 12.3 °C	8ch 12.3 °C	
3ch 12.3 °C	9ch 12.3 °C	

③ Measuring mode: Strain + temperature (RTD) mode

Monitor >	Monitor < >	Monitor <
1ch 12345 $\mu \epsilon$ 12.3 °C	7ch 12345 $\mu \epsilon$ 12.3 °C	10ch 12345 $\mu \epsilon$ 12.3 °C
2ch 12345 $\mu \epsilon$ 12.3 °C	8ch 12345 $\mu \epsilon$ 12.3 °C	
3ch 12345 $\mu \epsilon$ 12.3 °C	9ch 12345 $\mu \epsilon$ 12.3 °C	

Press the “SET” key or “ESC” key to go back to the [Monitor] menu.

#### NOTE

When measured values are 99999 $\mu\text{m}/\text{m}$  or 99.9°C, check sensor installations. Sensor cables may be broken.

## 9-2 MAINTENANCE MENU

### 9-2-1 To check conditions

This section describes how to check the current Measuring-point No., Measurement start time, Next measurement start time, The number of measurements (current total/pre-set total), and Interval time.

(1) Select the [Maintenance] → [Condition List].

Press the “SET” key

Change the target by pressing the “<” key and “>” key.

The target changes as follows.

[MEAS Point Name] → [Start Date and Time] → [Next MEAS Date&Time]  
→ [Times of MEAS] → [Measurement Interval]

To terminate checkings, press the “SET” key or “ESC” key.

The [Condition List] menu appears.

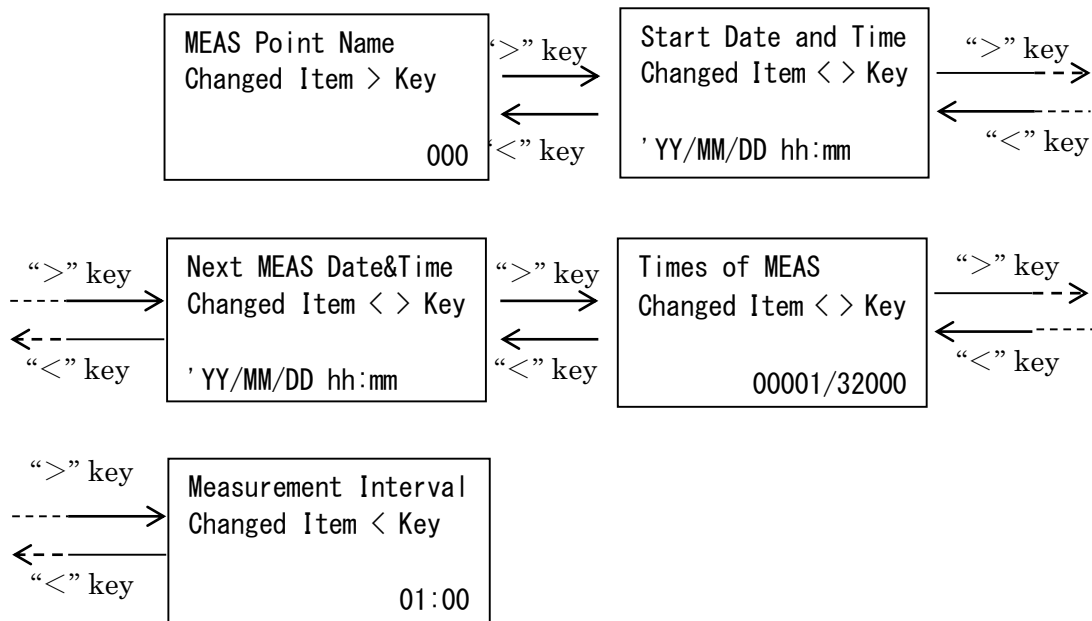

### 9-2-2 Self-diagnosis function

The self-diagnosis function checks the RMH-310A internal statuses.

The self-diagnosis function checks sensors, battery voltages, ROMs, and RAMs for displaying results.

(1) Select the [Maintenance] → [Self-Check].

Press the “SET” key.

The [Checking] appears during the self-diagnosis function.

(2) As the self-diagnosis function stops, the following windows appears.

Change the target by pressing the “<” key and “>” key.

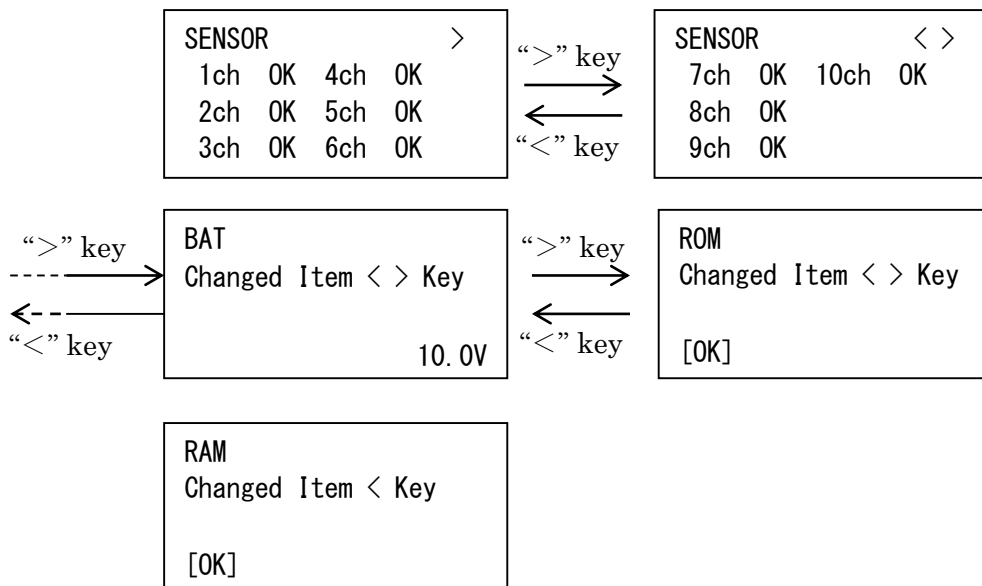

(3) Press the “SET” key or “ESC” key to go back to the [Self-Check] menu.

- SENSOR

Measures the bridge resistances of sensors for checking sensors.

[OK] Passed

[NG] A sensor is not connected.  
A resistance is not 350 ohm.  
A sensor cable is broken.  
A sensor is faulty.

Note that the measuring mode is “Strain mode” during the self-diagnosis function.

- BAT

Measures the current battery voltage.

The RMH-310A power supply is 6 to 15 VDC.

Do not connect the power supply, larger than the 15 VDC. Or, it may cause troubles.

Do not connect the power supply, lower than the 6 VDC. Or, the product will not operate properly.

The RMH-310A has the largest current consumption when retrieving data.

Before retrieving data, make sure the RMH-310A battery has the enough voltage and current-carrying capacity. Or, the RMH-310A will be turned OFF.

- ROM/RAM

Checks the information consistencies, saved in the built-in nonvolatile memory and volatile memory.

[OK] Passed

[NG] A ROM/RAM is faulty.  
Contact Kyowa or our representatives.

9-2-3 To set the built-in clock

This section describes how to set the RMH-310A built-in clock.

- (1) Select the [Maintenance] → [Set the Date&Time].

Press the “SET” key

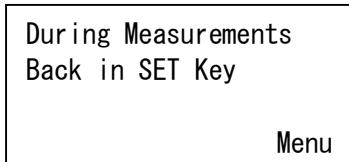

- (2) Enter the current date and time.

The cursor moves Year/Month/Day/Hour/Minute.

Suppose the current date and time is June 28, 2014.

Enter '14/06/28/12 : 30.

To move the cursor

“<”key and “>” key

To increase numbers

“^” key

To decrease numbers

“v” key

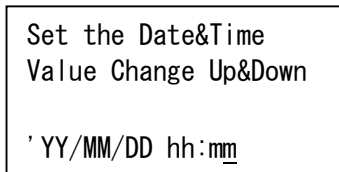

- (3) Press the “SET” key for determination.

The built-in clock starts from 00 second

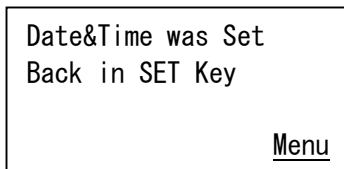

- (4) Press the “SET” key to go back to the [Set the Date&Time] menu.

**NOTE**

- You are not able to change date and time during measurements.  
When you select [Set the Date&Time] menu during measurements, the following error message appears.

Press the “SET” key to go back to the [Set the Date&Time] menu.

During Measurements  
Menu

- Leap year  
The RMH-310A divides the last 2 digits of the year by 4. If it divides exactly, the RMH-310A corrects the year as a leap year.  
Year range: 05 to 99  
The RMH-310A is able to correct the leap year between 2005 and 2099 automatically.

- Errors between the built-in clock and actual time are as follows.  
The built-in clock errors vary with ambient temperatures.  
-20°C: -3.7 to +7.8 sec/day  
+20 to 30°C: -1.6 to +2.5 sec/day  
+50°C: -3.5 to +0.6 sec/day

#### 9-2-4 To retrieve backup data

This section describes how to retrieve backup data.

Since the RMH-310A backs up the previous measured data automatically, you are able to retrieve the mistakenly cleared measured data again.

The RMH-310A outputs data in 2 formats; binary format data files (.DA2) and text format files (.CSV).

Note that the RMH-310A backs up the previous measured data.

The RMH-310A does not back up the measured data before last.

(1) Select the [Maintenance] → [Data backup].

Press the “SET” key

After this, see “8 - 1 BASIC OPERATIONS.”

## 9-2-5 To check versions

This section describes how to check versions.

(1) Select the [Maintenance] → [Version].

Press the “SET” key

Version 01.00
------------------

(2) Press the “ESC” key to go back to the [Version] menu.

## 1 0 TROUBLE SHOOTING

Trouble	Causes and checking items
The display does not work correctly.	<ul style="list-style-type: none"> <li>• The POWER connector is not securely connected.</li> <li>→ Securely connect the POWER connector.</li> <li>• The power supply voltage is exceeding the range of 6 to 15 VDC.</li> <li>→ Use the power supply voltage within 6 to 15 VDC.</li> <li>• The batteries are not connected correctly.</li> <li>→ Correctly connect the batteries.</li> <li>• The battery remaining capacity is not enough.</li> <li>→ Replace the battery having enough capacity.</li> </ul>
Self-diagnosis function results: SENSOR NG	<ul style="list-style-type: none"> <li>• The sensor is not correctly connected.</li> <li>→ Correctly connect the sensor.</li> <li>• The bridge resistance of the sensor is not 350 ohm.</li> <li>→ Replace the sensor with a new one. Use a sensor with the bridge resistance 350 ohm only.</li> <li>• The sensor is faulty.</li> <li>→ Replace the sensor with a new one.</li> <li>• Metals (excluding sensors) is touching terminal blocks.</li> </ul>
Operation stops and accepts no instruction at all.	<ul style="list-style-type: none"> <li>• The operation failed due to noise.</li> <li>→ Turn OFF the power and turn ON again.</li> </ul> <p>If the same phenomenon still generates due to noise, take appropriate countermeasures for removing the noise from operating environment, power supply, etc.</p>
The measured value varies.	<ul style="list-style-type: none"> <li>• The sensor is loosen.</li> <li>→ Securely fix the sensor.</li> </ul> <p>Check whether cables are broken. Note that you are not able to check whether cables are broken by using indicating values, since the RMH-310A scanning speed is slow. To check whether cables are broken, shake cables by measuring the sensor resistances with a circuit tester.</p> <ul style="list-style-type: none"> <li>• The operation failed due to noise.</li> <li>→ Take appropriate countermeasures for removing the noise.</li> </ul> <p>Be sure to connect the GND terminal to the ground. Connect the GND terminal of the RMH-310A and that of buildings. Be sure to use vinyl-coated cables (nominal cross section: 0.75 mm<sup>2</sup>). The best approach varies with environmental conditions. Try to connect GND terminals for decreasing noise and for stable measurements. Basically single-point grounding is required. Or, it may create loops and receive noise. When sensors are grounded: Disconnect the GND terminal of the RMH-310A. When sensors are not grounded: Connect the GND terminal of the RMH-310A.</p>

Trouble	Causes and checking items
The measured value varies.	<ul style="list-style-type: none"> <li>• When measuring temperatures with thermocouples</li> <li>→ Leave the product as it is until the input terminal temperature is stable.</li> <li>Cover terminal blocks before measuring thermocouples.</li> <li>Do not expose the product to air-conditioner wind or direct sunlight.</li> <li>Or, it may cause temperature errors.</li> <li>Place the product on a stable place.</li> <li>Or, it may cause temperature errors.</li> </ul>
The measured value is incorrect.	<ul style="list-style-type: none"> <li>• Correct sensors and correct cables are not connected.</li> <li>→ Check whether sensors and cables are broken or have insulation failure.</li> <li>    Check the RMH-310A settings (including the measuring mode) and wire connections.</li> <li>→ Check whether the measuring target has potential larger than the ground.</li> <li>Generally thermocouples measure minute potential differences.</li> <li>Before attaching thermocouples on metals having potential, cover the thermocouple ends by using thermally conductive insulators.</li> </ul>
The file size is "0 kB".	<ul style="list-style-type: none"> <li>• Failed to retrieve data.</li> <li>→ Retrieve data again.</li> <li>→ When the RMH-310A is turned OFF, the RMH-310A retrieves data incorrectly and create 0 kB file on the USB memory.</li> <li>Some commercially available USB memories may not work due to incompatibility issues.</li> <li>→ Use the accessory USB memory(Format: File system FAT 32, Allocation unit size 4096 bytes.).</li> </ul>
Failed to set data by using the USB memory.	<ul style="list-style-type: none"> <li>• The accessory supplementary tool is not used.</li> <li>→ Use the accessory USB memory and supplementary tool.</li> </ul>
Failed to retrieve data by using the USB memory.	<ul style="list-style-type: none"> <li>• The “Collecting Data” appears but the percentage does not increase at all.</li> <li>    The “Collected in Failed” appears after several minutes.</li> <li>    The 0 kB file appears on the USB memory.</li> <li>→ The USB memory has file system error or bad sector.</li> <li>    To fix file system errors or bad sectors, run an error check on the USB memory from the PC.</li> <li>    [Example: Windows 7]</li> <li>    Start &gt; Computer &gt;Removable disk &gt; Properties &gt; Tool &gt; Error Checking</li> <li> </li> <li>*Do not connect/disconnect the USB memory while retrieving data.</li> <li>Or, it may cause file system errors or bad sectors.</li> <li>However, you do not notice the errors on the PC because of the Operating System's supports.</li> <li>You are not able to fix file system errors or bad sectors on the RMH-310A. Before retrieving data from the RMH-310A at the remote area, we recommend running an error check from the PC in advance.</li> </ul>

Trouble	Causes and checking items
<p>Measured data disappear. Pre-set date and time disappear.</p>	<ul style="list-style-type: none"> <li>• The backup battery is not within the expiration date. The RMH-310A keeps the measured data and operates the built-in clock by using the backup battery. (Note that the backup battery is not RB-5A/RB-10A.) Check the expiration date of the backup battery, on the RMH-310A side panel. After the expiration date has passed, contact Kyowa or our representatives. Our service center will replace the backup battery with a new one. Backup battery replacement will be charged. (The expiration date of the backup battery is approx. 10 years from the date of manufacture.)</li> </ul>
<p>The measured value of a thermocouples is incorrect.</p>	<ul style="list-style-type: none"> <li>• Check whether the measuring mode is K-type thermocouple/T-type thermocouple.</li> <li>• Check whether thermocouple cables are broken.</li> <li>• Check whether the reference junction compensation works correctly as follows. Short-circuit the terminal W (-) and terminal G (+) by using a lead wire. Make sure the electromotive force is 0 V. Make sure the terminal block temperature (near the ambient temperature) appears as the indicating value.</li> </ul>

## 1 1 SPECIFICATIONS

(1) The number of channels	10
(2) Measuring target	Strain gage civil engineering transducer Civil engineering transducer with temperature measuring function Strain gage transducer Thermocouple (K-type and T-type)
(3) Applicable bridge resistance	350 ohm (full bridge system) [NOTE] When the bridge excitation line of a sensor has a temperature property compensating resistor, the RMH-310A will not compensate the temperature property.
(4) Cable length	Up to 2.0 km, 4-conductor (0.5mm <sup>2</sup> ) shielded cable
(5) Gage factor	2.00 fixed
(6) Bridge excitation	Approx. 2.19m ADC (constant current)
(7) Measuring range	Strain $\pm 20000 \mu\text{m/m}$ Temperature (civil engineering transducer with temperature measuring function) $-30.0 \text{ to } +70.0^\circ\text{C}$ Temperature (thermocouple) K: $-200 \text{ to } +1200^\circ\text{C}$ T: $-200 \text{ to } +350^\circ\text{C}$ * Thermocouple resistance: 1000 ohm or less
(8) Resolution	Strain $1 \mu\text{m/m}$ Temperature (civil engineering transducer with temperature measuring function) $0.1^\circ\text{C}$ Temperature (thermocouple) $0.1^\circ\text{C}$
(9) Measuring accuracy	Strain $\pm 0.1\% \text{F.S.}$ Temperature (civil engineering transducer with temperature measuring function) $\pm 0.5^\circ\text{C}$ Temperature (thermocouple) $\pm (0.1\% \text{rdg} + 1.0)^\circ\text{C}$ Accuracy of the internal reference junction compensation $\pm 2.0^\circ\text{C}$ (when the input terminal temperature is stable.)
*The accuracy of the internal reference compensation junction and accuracy of thermocouples are not included.	
(10) Temperature stability	Strain Zero point: Within $\pm 1 \mu\text{m/m}$ Sensitivity: Within $\pm 0.02\% / ^\circ\text{C}$ Temperature (civil engineering transducer with temperature measuring function) Zero point: Within $\pm 0.025\% \text{F.S.} / ^\circ\text{C}$ Sensitivity: Within $\pm 0.04\% / ^\circ\text{C}$ Temperature (thermocouple) Zero point: Within $\pm 0.025\% \text{F.S.} / ^\circ\text{C}$ Sensitivity: Within $\pm 0.04\% / ^\circ\text{C}$

(11) Measuring time	Within 40 seconds/10 channels (scanning method)
(12) Current for measuring temperature	Approx. 0.24mA ADC (constant current)
(13) Data storage	32000 data/channel
(14) Clock	Year (2 digits of the Gregorian calendar), month, day, hour, minute
(15) Interval measurement	1 to 59 minutes (1 minute step) 1 to 99 hours (1 hour step) (1 minute step/1 hour step)
(16) Check function	Self diagnosis the following items. Sensor checking Strain mode: Parallel resistance method Temperature (RTD) mode: Parallel resistance method Strain + temperature (RTD) mode: Parallel resistance method K-type thermocouple mode: Burnout checking T-type thermocouple mode: Burnout checking Battery voltage, memory checking
(17) Display	LCD (20 digits × 4 lines, no backlight)
(18) Display function	Displays the following items on the LCD. Measuring state, current time, retrieve data, real-time monitor, start/stop measurement, measuring conditions, self-diagnosis, date and time settings, retrieve backup data, and version.
(19) Operation	Operation keys (<, >, ^, and v), ON/OFF key, SET key, ESC key
(20) Interface	USB 2.0 (for saving data in an USB memory only)
(21) Power supply	6 to 15 VDC (RB-10A)
(22) Current consumption	When in operation: 100mA or less When not in operation: 100µA or less (at 6 VDC)
(23) Input terminal block	Soldering, screw-fixed terminal block, M3
(24) The number of measurements	7000 or more With the optional RB-10A (10Ah), 23°C, 10 minutes for interval measurements.
(25) Operating temperature range	-20 to 50°C (varies with the operating temperature range of the USB memory)
(26) Operating humidity range	10 to 95%RH
(27) Others	No dust and no induction noise from large-capacity motor, etc.
(28) Dimensions	170 (W) × 230 (H) × 60 (D) mm (excluding protrusions)
(29) Weight	2kg or less (excluding batteries)
(30) Accessories	Industrial USB memory with extended temperature range Battery cable (for the RB-10A)
(31) Others	With lightning surge protector The RMH-310A retrieves data in 2 formats; binary format data files (.DA2) and text format files (.CSV). The binary format data files (.DA2) requires less time than the text format files (.CSV). The supplementary tool is saved in the attached USB memory. The instruction manual, outside drawing, and specifications are saved in the attached USB memory.

1 1 - 1 OUTSIDE DRAWING

