

THE INFORMATION CONTAINED IN THIS DRAWING IS THE SOLE PROPERTY OF PLASTICASE ANY REPRODUCTION IN PART OR WHOLE WITHOUT THE WRITTEN PERMISSION OF PLASTICASE IS PROHIBITED.

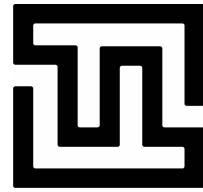

INSTRUMENTS
**TECHNO
TEST**

REVISIONS			
REV.	DESCRIPTION	DATE	APPROVED

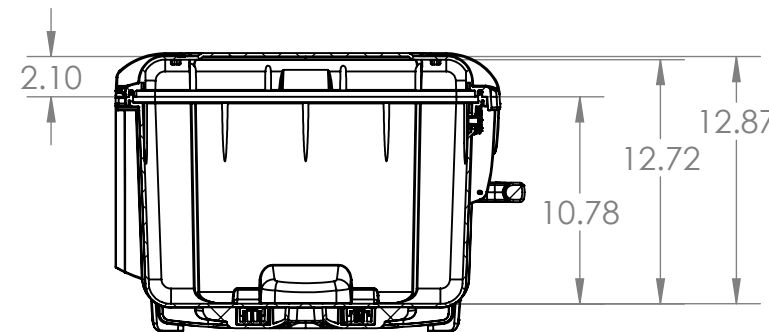
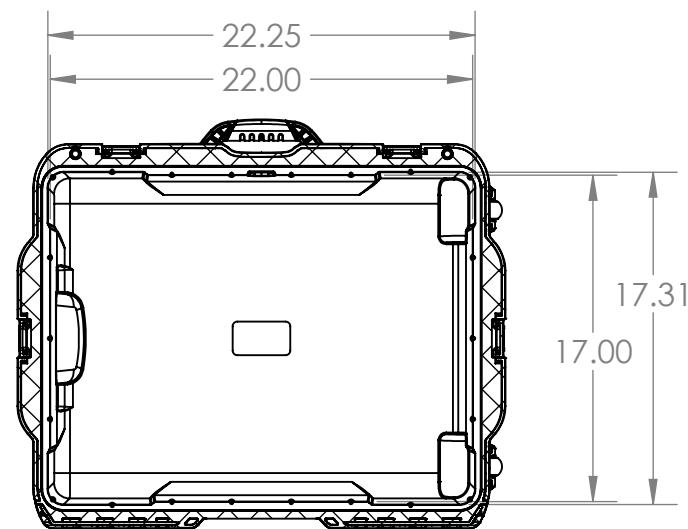
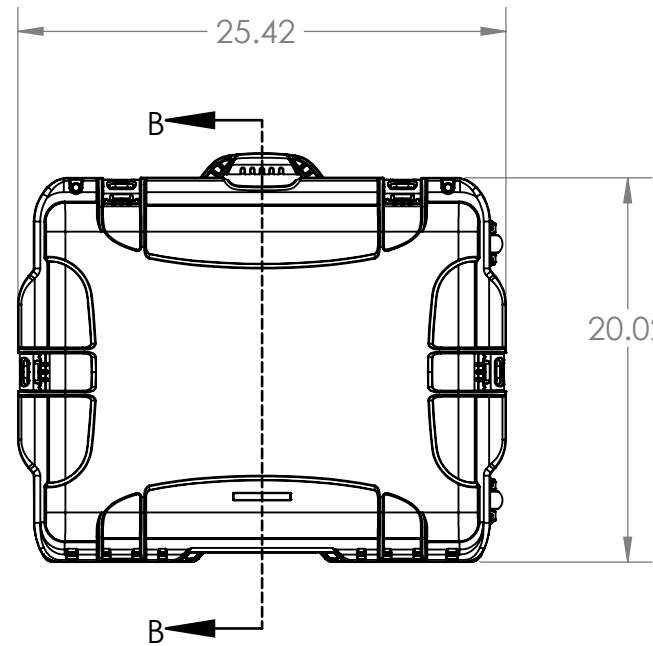
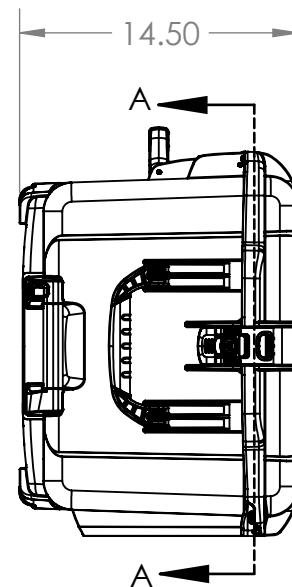
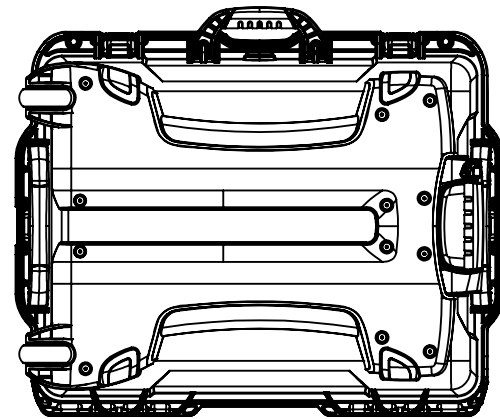
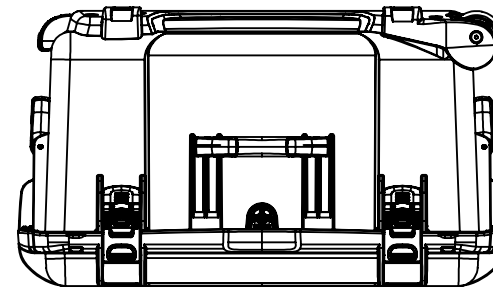

NANUK 960 Specifications

Case Weight Empty	19.22lbs / 8.72kg
Interior Length	22.00" / 559mm
Interior Width	17.00" / 432mm
Interior Height	12.87" / 327mm
Interior Lid Depth	2.10" / 54mm
Interior Base Depth	10.78" / 274mm
Exterior Length	25.42" / 646mm
Exterior Width	20.02" / 509mm
Exterior Height	14.50" / 368mm
Master Pack Qty.	1
Master Pack Wt.	N/A
Max Buoyancy	167.55 lbs / 76.0 kg

PARTS LIST

UNLESS OTHERWISE SPECIFIED DIMENSIONS ARE IN INCHES	CAD GENERATED DRAWING, DO NOT MANUALLY UPDATE		PLASTICASE
	APPROVALS	DATE	
	DRAWN P.L.O.	30/10/2013	
	CHECKED		
MATERIAL	RESP ENG		NANUK 960
FINISH --	MFG ENG		
DO NOT SCALE DRAWING	QUAL ENG		
SIZE B		DWG. NO.	REV.
SCALE 1:10		CAD FILE: 960_Assembly	SHEET 1 OF 1