

THE INFORMATION CONTAINED IN THIS DRAWING IS THE SOLE PROPERTY OF PLASTICASE ANY REPRODUCTION IN PART OR WHOLE WITHOUT THE WRITTEN PERMISSION OF PLASTICASE IS PROHIBITED.

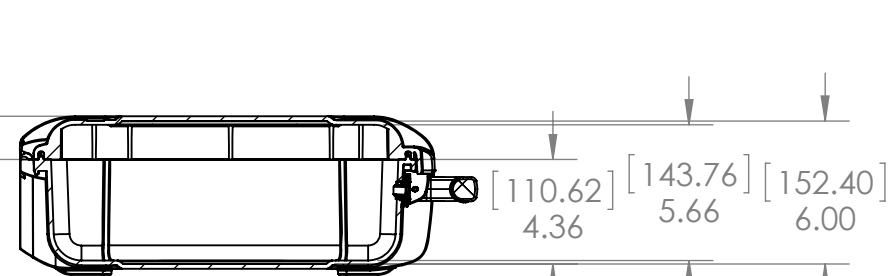

REVISIONS			
REV.	DESCRIPTION	DATE	APPROVED

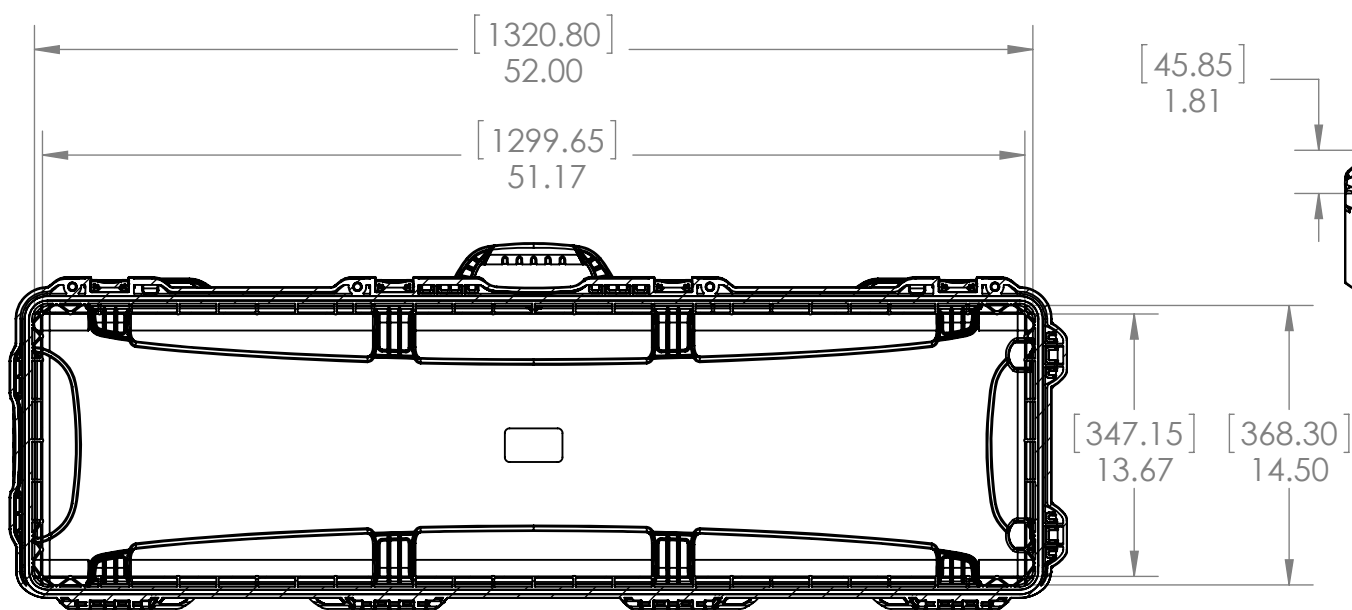
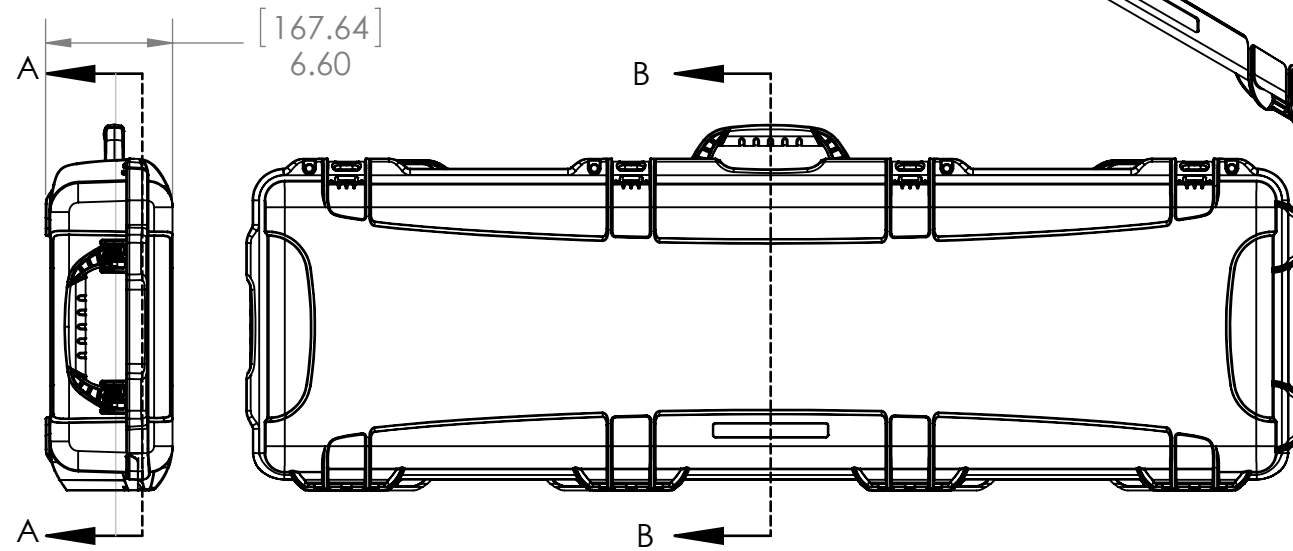
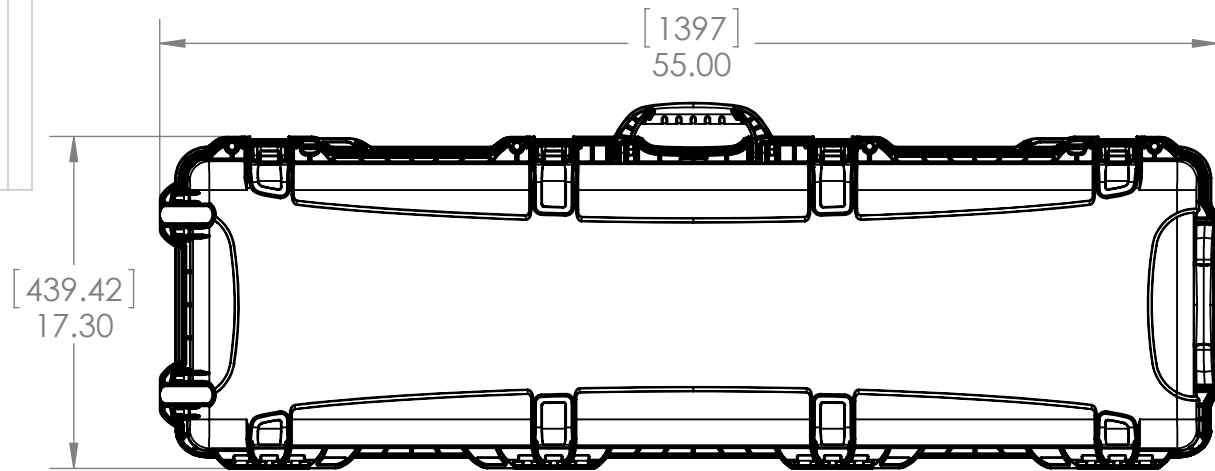
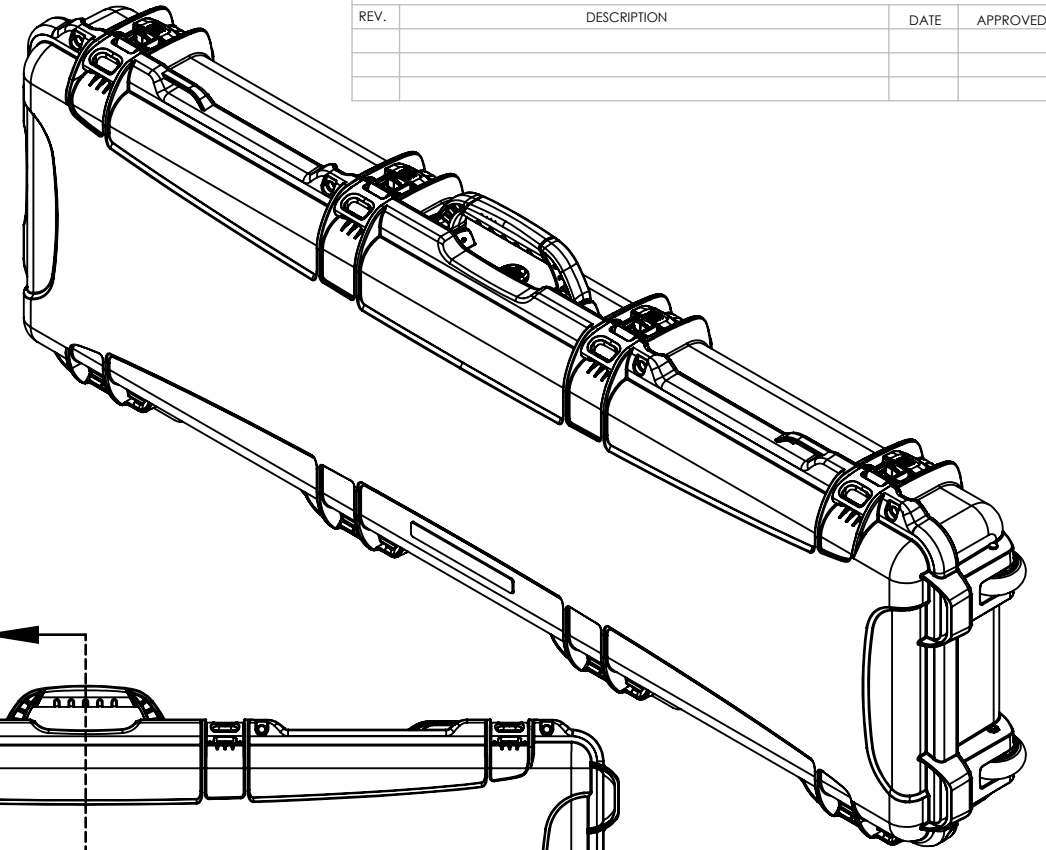
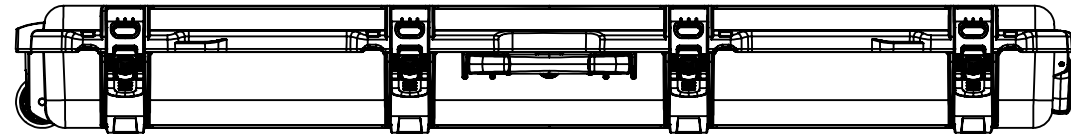

NANUK 995 Specifications	
Case Weight Empty	21.6lbs / 9.8kg
Interior Length	52" / 1321mm
Interior Width	14.5" / 368mm
Interior Height	6" / 152mm
Interior Lid Depth	1.6" / 41mm
Interior Base Depth	4.4" / 111mm
Exterior Length	55.1" / 1399mm
Exterior Width	17.3" / 440mm
Exterior Height	6.6" / 168mm
Master Pack Qty.	1
Master Pack Wt.	N/A
Max Buoyancy	N/A

SECTION A-A
SCALE 1:10

SECTION B-B
SCALE 1:8

PARTS LIST			
UNLESS OTHERWISE SPECIFIED DIMENSIONS ARE IN INCHES		CAD GENERATED DRAWING, DO NOT MANUALLY UPDATE	
APPROVALS		DATE	
DRAWN	P.L.O.	26/02/2015	
CHECKED			
RESP ENG			
FINISH		MFG ENG	
DO NOT SCALE DRAWING		QUAL ENG	
		PLASTICASE	
		NANUK 995	
SIZE	DWG. NO.	REV.	
B			
SCALE	1:12	CAD FILE:	995 Assembly-REV-BEN SHEET 1 OF 1