

THE INFORMATION CONTAINED IN THIS DRAWING IS THE SOLE PROPERTY OF PLASTICASE ANY REPRODUCTION IN PART OR WHOLE WITHOUT THE WRITTEN PERMISSION OF PLASTICASE IS PROHIBITED.

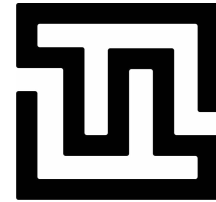

**INSTRUMENTS
TECHNO
TEST**

REVISIONS			
REV.	DESCRIPTION	DATE	APPROVED

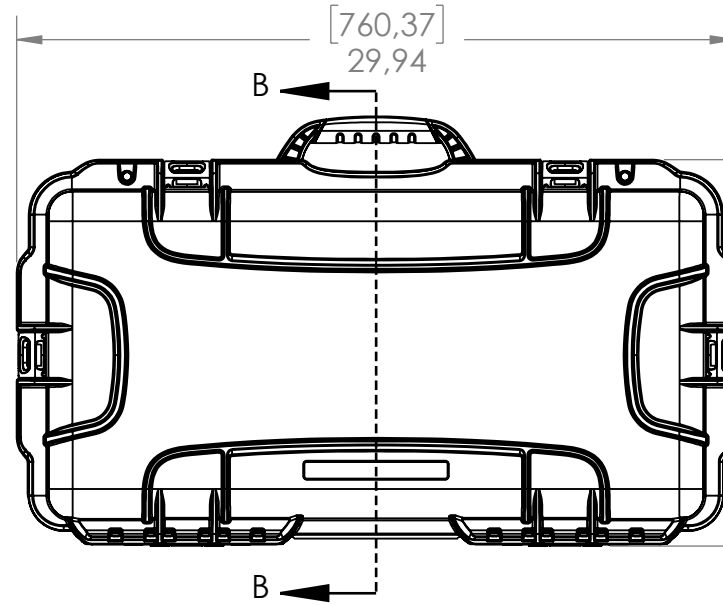
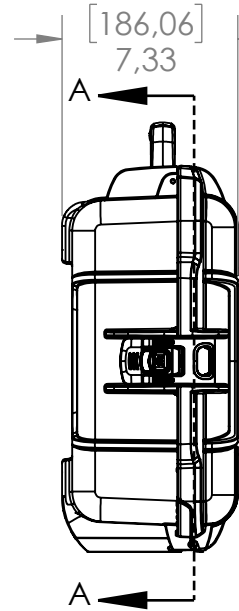
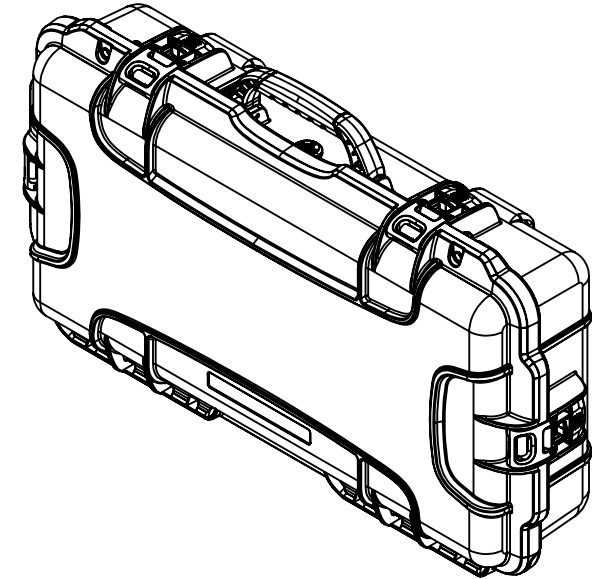
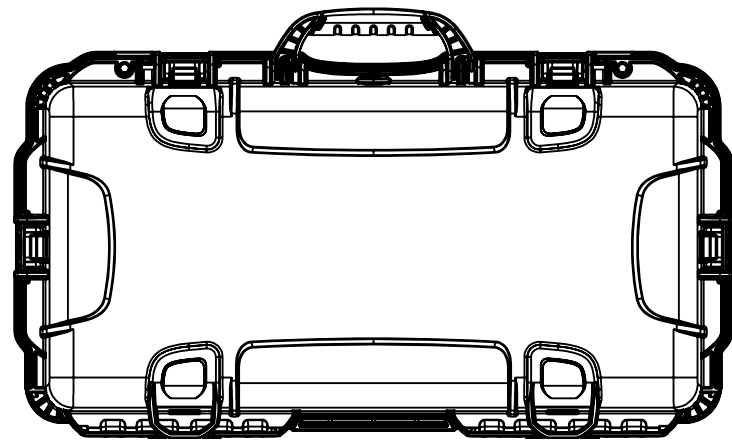
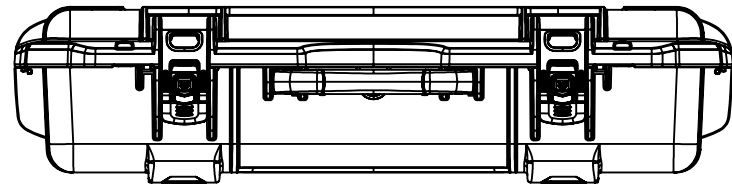

[408,86]
16,10

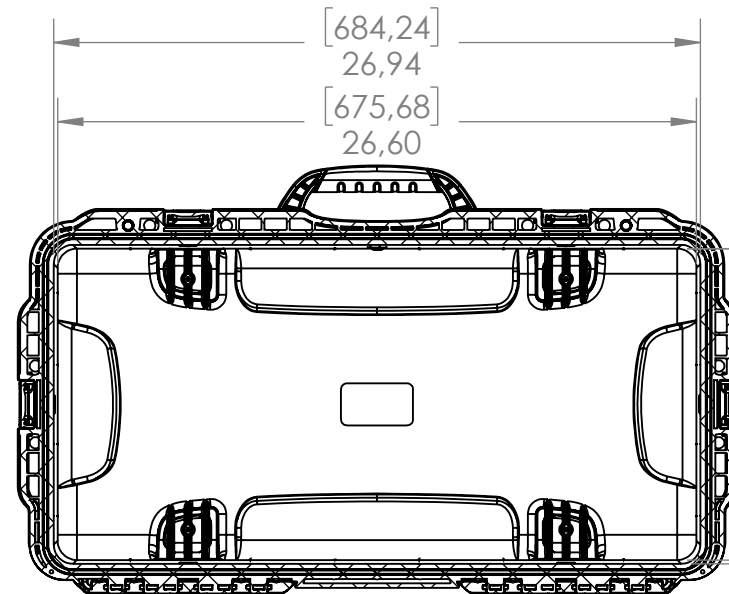

SECTION A-A
SCALE 1 : 8

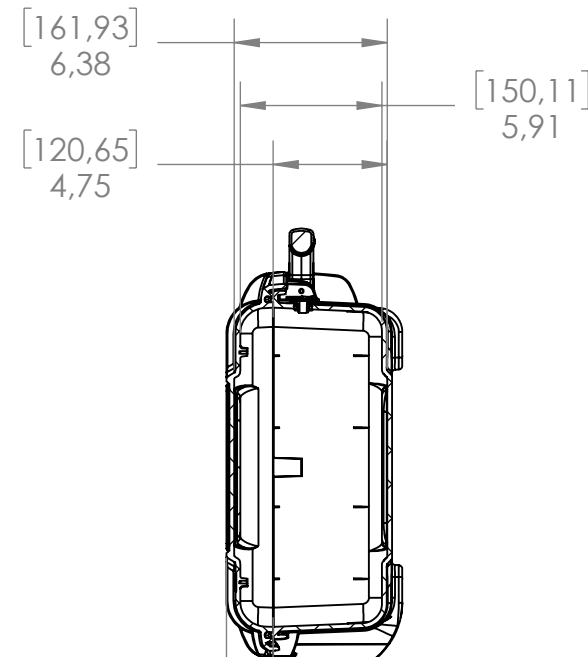

SECTION B-B
SCALE 1 : 8

NANUK 980 Specifications

Case Weight Empty	10.8lbs / 4.9kg
Interior Length	26.9" / 684mm
Interior Width	13.1" / 333mm
Interior Height	6.3" / 161mm
Interior Lid Depth	1.6" / 41mm
Interior Base Depth	5.91" / 150mm
Exterior Length	29.9" / 760mm
Exterior Width	16.1" / 408mm
Exterior Height	7.3" / 186mm
Master Pack Qty.	1
Master Pack Wt.	N/A
Max Buoyancy	N/A

PARTS LIST

UNLESS OTHERWISE SPECIFIED DIMENSIONS ARE IN INCHES	CAD GENERATED DRAWING, DO NOT MANUALLY UPDATE		PLASTICASE
	APPROVALS	DATE	
	DRAWN MK	2023-01-25	
	CHECKED		
MATERIAL	RESP ENG		NANUK 980
FINISH --	MFG ENG		
DO NOT SCALE DRAWING	QUAL ENG		
SIZE B		DWG. NO.	REV.
SCALE 1:12		CAD FILE: 980_Assembly_a.03	SHEET 1 OF 1