

THE INFORMATION CONTAINED IN THIS DRAWING IS THE SOLE PROPERTY OF PLASTICASE ANY REPRODUCTION IN PART OR WHOLE WITHOUT THE WRITTEN PERMISSION OF PLASTICASE IS PROHIBITED.

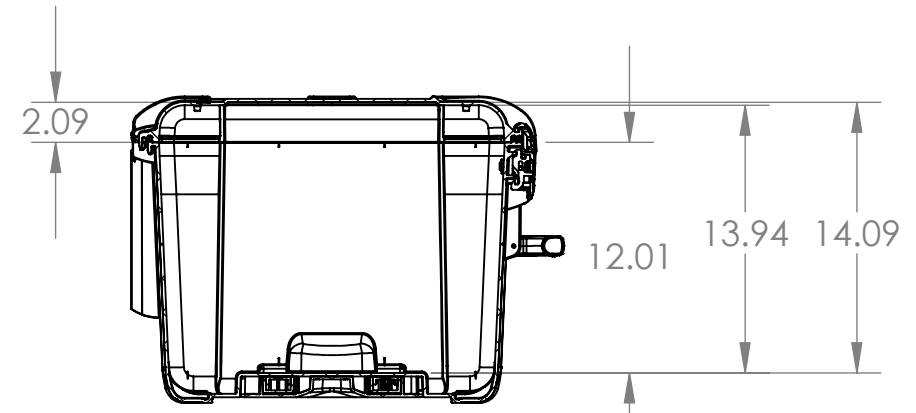

REVISIONS			
REV.	DESCRIPTION	DATE	APPROVED

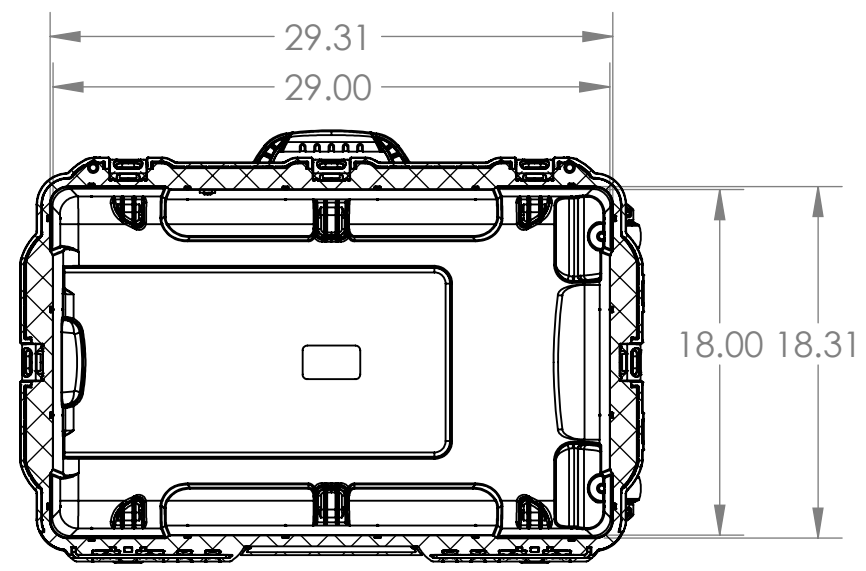
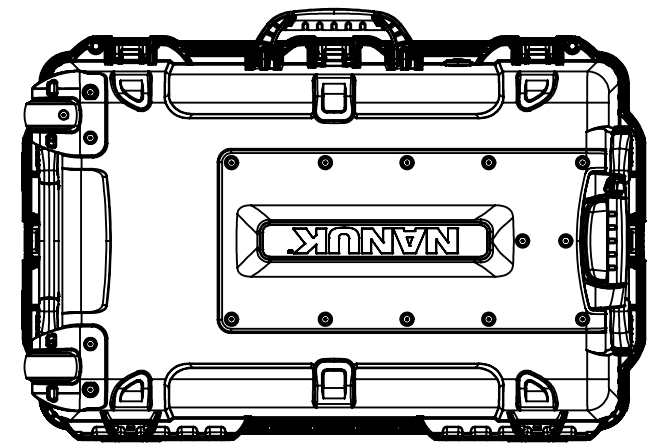
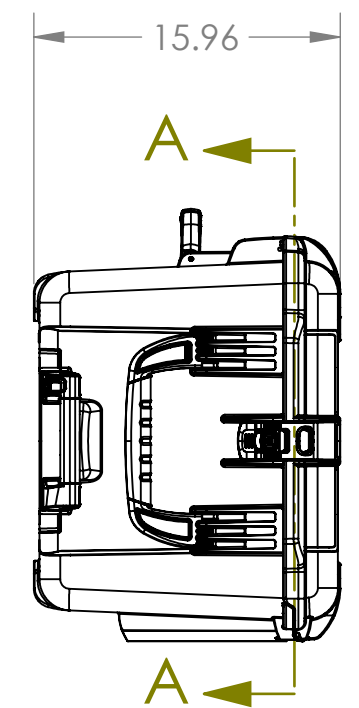
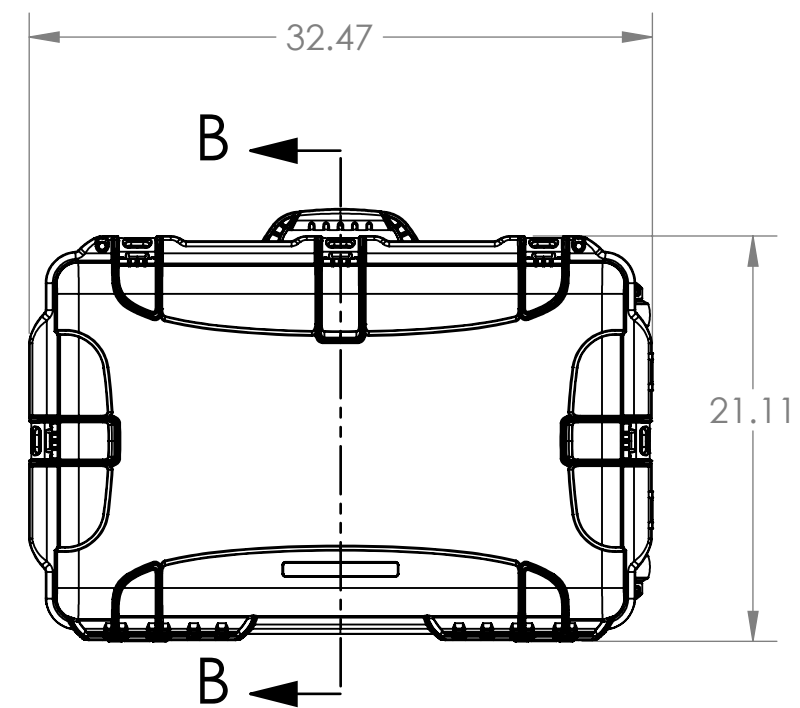
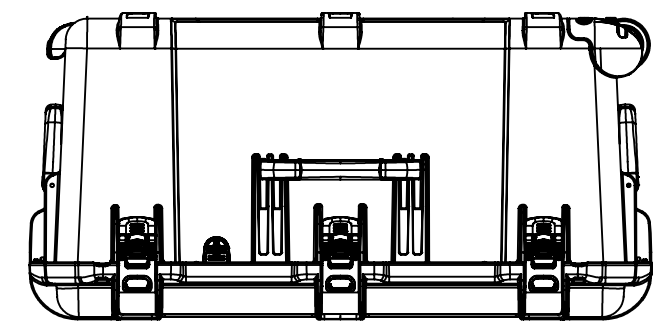
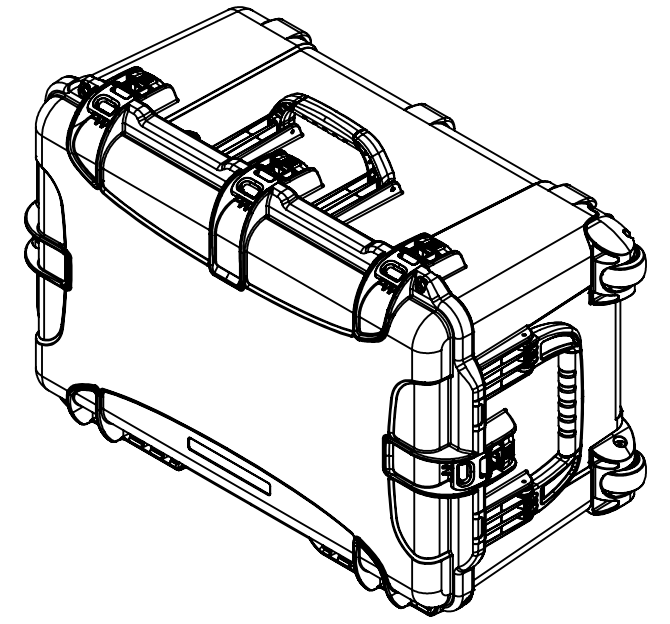

NANUK 965 Specifications	
Case Weight Empty	24.65 lbs / 11.18 kg
Interior Length	29.0" / 737 mm
Interior Width	18.0" / 457 mm
Interior Height	13.9" / 353mm
Interior Lid Depth	2.1" / 53 mm
Interior Base Depth	12.0" / 305 mm
Exterior Length	32.5" / 826 mm
Exterior Width	21.1" / 536 mm
Exterior Height	15.9" / 404 mm
Master Pack Qty.	1
Master Pack Wt.	TBD
Max Buoyancy	TBD

PARTS LIST			
UNLESS OTHERWISE SPECIFIED DIMENSIONS ARE IN INCHES	CAD GENERATED DRAWING, DO NOT MANUALLY UPDATE		
	APPROVALS	DATE	
MATERIAL	DRAWN	S.C.	31/10/2019
	CHECKED		
FINISH	RESP ENG		
	MFG ENG		
DO NOT SCALE DRAWING	QUAL ENG		

PLASTICASE

NANUK 965

SIZE B	DWG. NO.	REV.
SCALE 1:10	CAD FILE: 965_Assembly_p.00_14	SHEET 1 OF 1

SECTION A-A

SECTION B-B