

THE INFORMATION CONTAINED IN THIS DRAWING IS THE SOLE PROPERTY OF PLASTICASE ANY REPRODUCTION IN PART OR WHOLE WITHOUT THE WRITTEN PERMISSION OF PLASTICASE IS PROHIBITED.

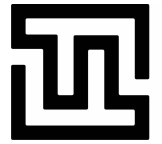

**INSTRUMENTS
TECHNO
TEST**

REVISIONS			
REV.	DESCRIPTION	DATE	APPROVED

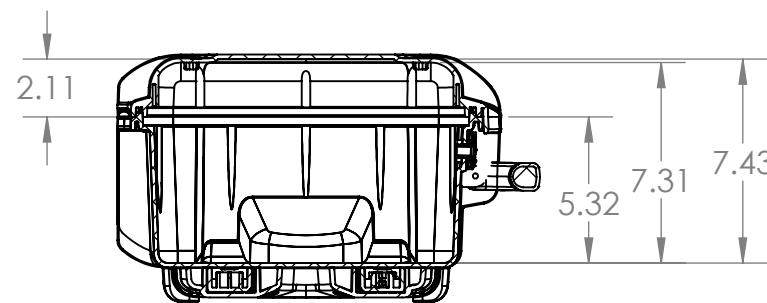
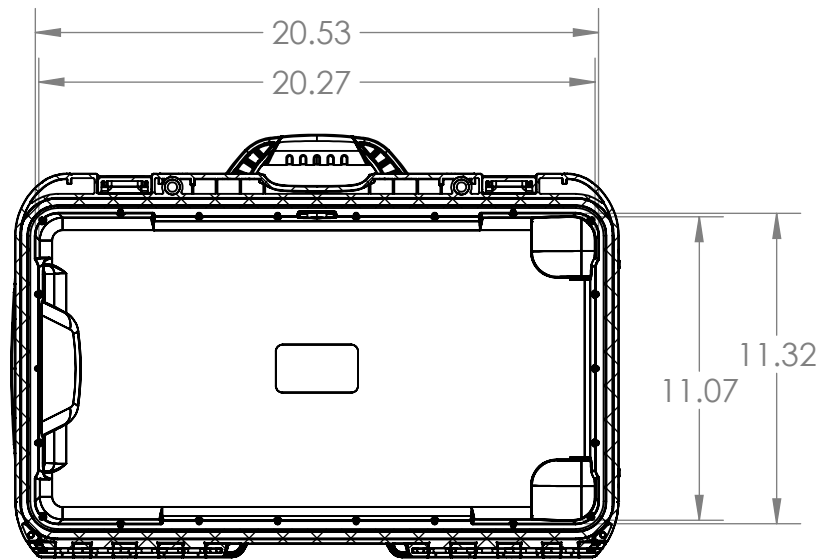
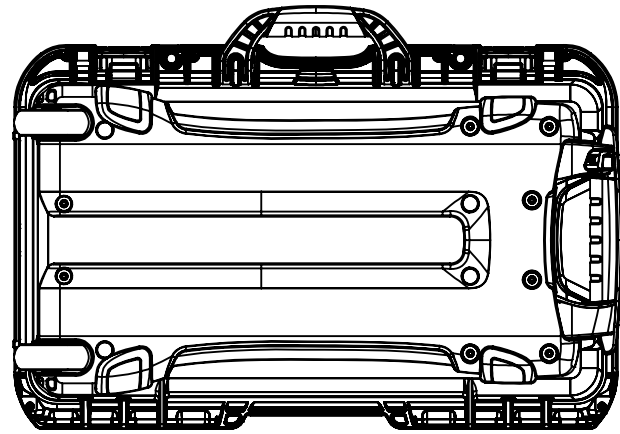
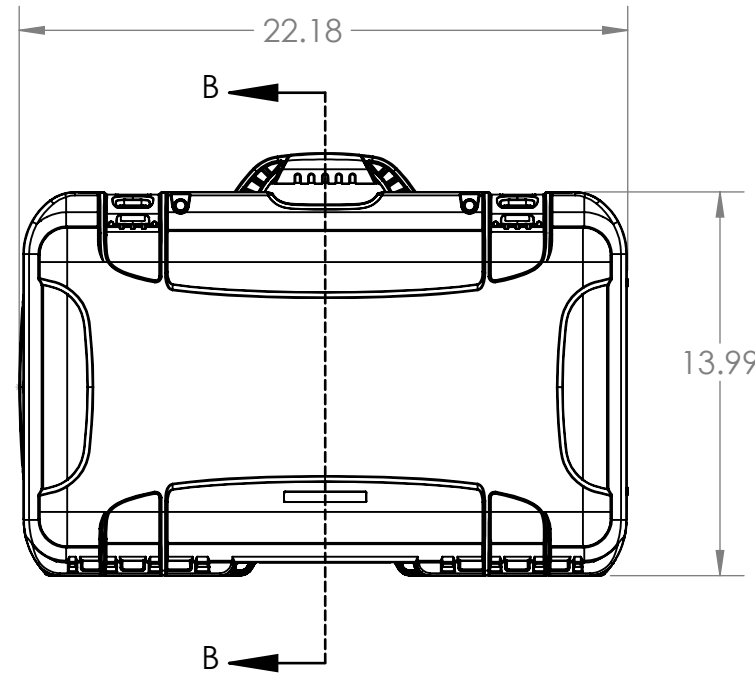
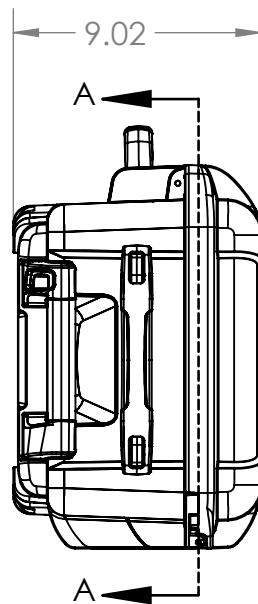
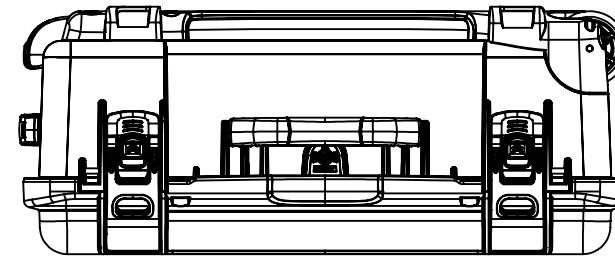

NANUK 935 Specifications

Case Weight Empty	11.6lbs / 5.2kg
Interior Length	20.27" / 515mm
Interior Width	11.07" / 281mm
Interior Height	7.43" / 189mm
Interior Lid Depth	2.11" / 54mm
Interior Base Depth	5.32" / 135mm
Exterior Length	22.18" / 563mm
Exterior Width	13.99" / 355mm
Exterior Height	9.02" / 229mm
Master Pack Qty.	1
Master Pack Wt.	12.7lbs / 5.7kg
Max Buoyancy	58 lbs / 26.44 kg

PARTS LIST

UNLESS OTHERWISE SPECIFIED DIMENSIONS ARE IN INCHES	CAD GENERATED DRAWING, DO NOT MANUALLY UPDATE		PLASTICASE
	APPROVALS	DATE	
	DRAWN P.L.O.	29/10/2013	
	CHECKED		
MATERIAL	RESP ENG		NANUK 935
FINISH --	MFG ENG		
DO NOT SCALE DRAWING	QUAL ENG		
	SIZE B	DWG. NO.	REV.
	SCALE 1:7	CAD FILE: 935_ass_8.2_Rev3 PC+ABS	SHEET 1 OF 1