

THE INFORMATION CONTAINED IN THIS DRAWING IS THE SOLE PROPERTY OF PLASTICASE ANY REPRODUCTION IN PART OR WHOLE WITHOUT THE WRITTEN PERMISSION OF PLASTICASE IS PROHIBITED.

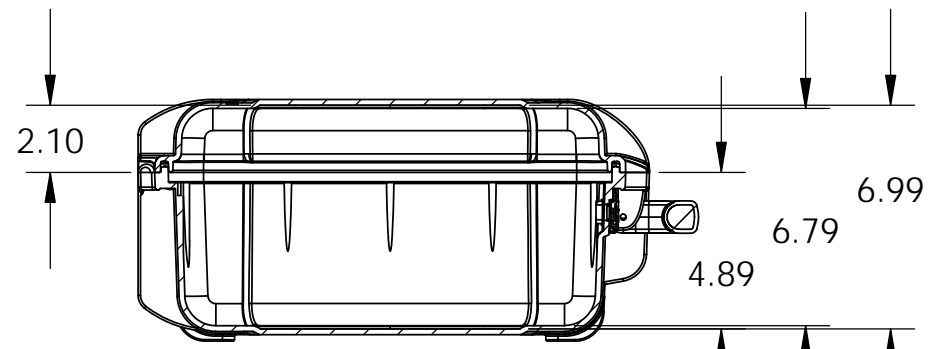

REVISIONS			
REV.	DESCRIPTION	DATE	APPROVED

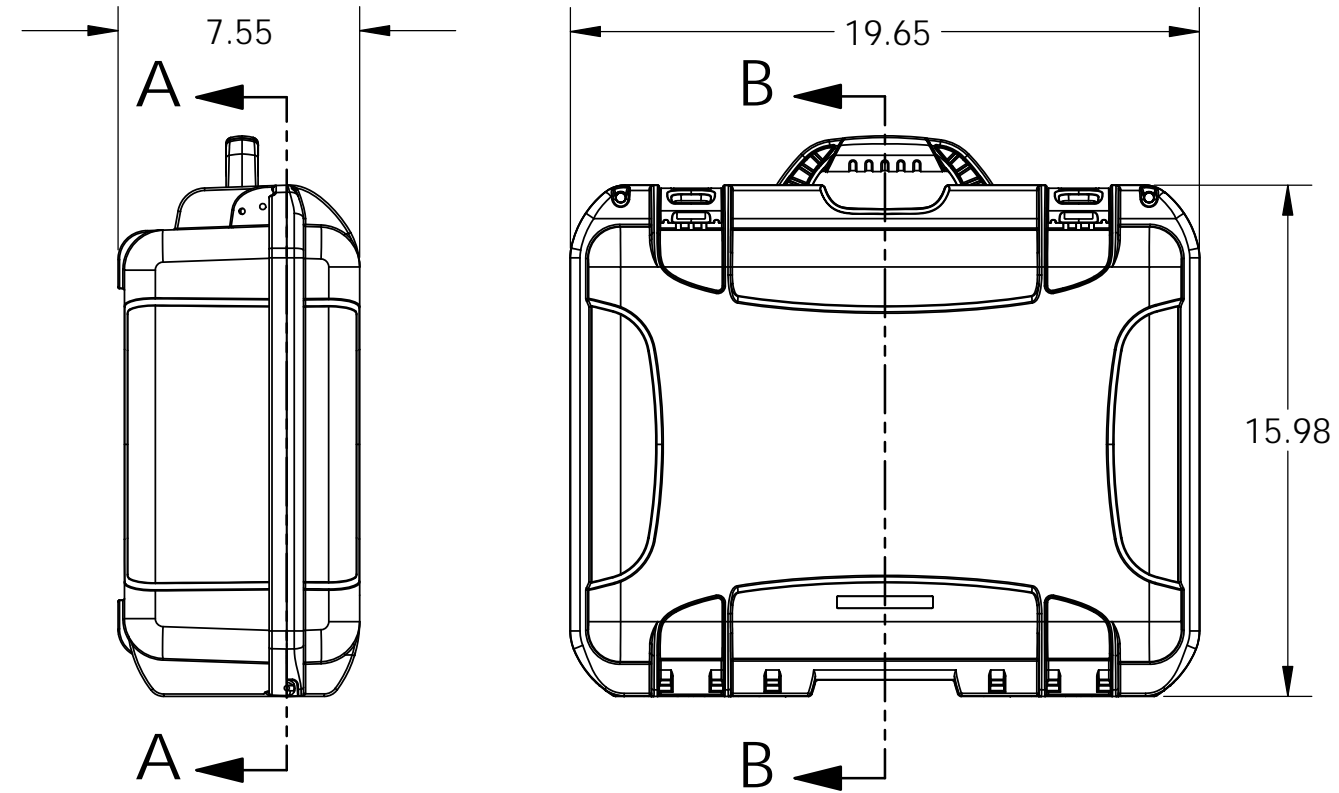
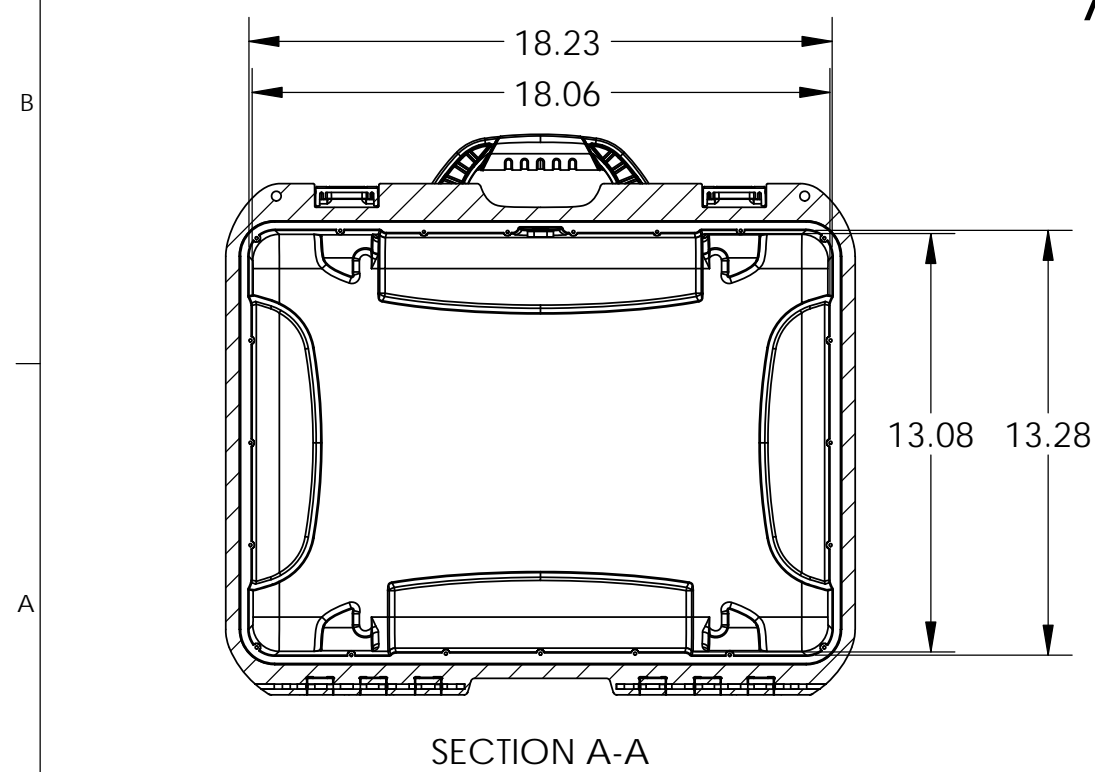
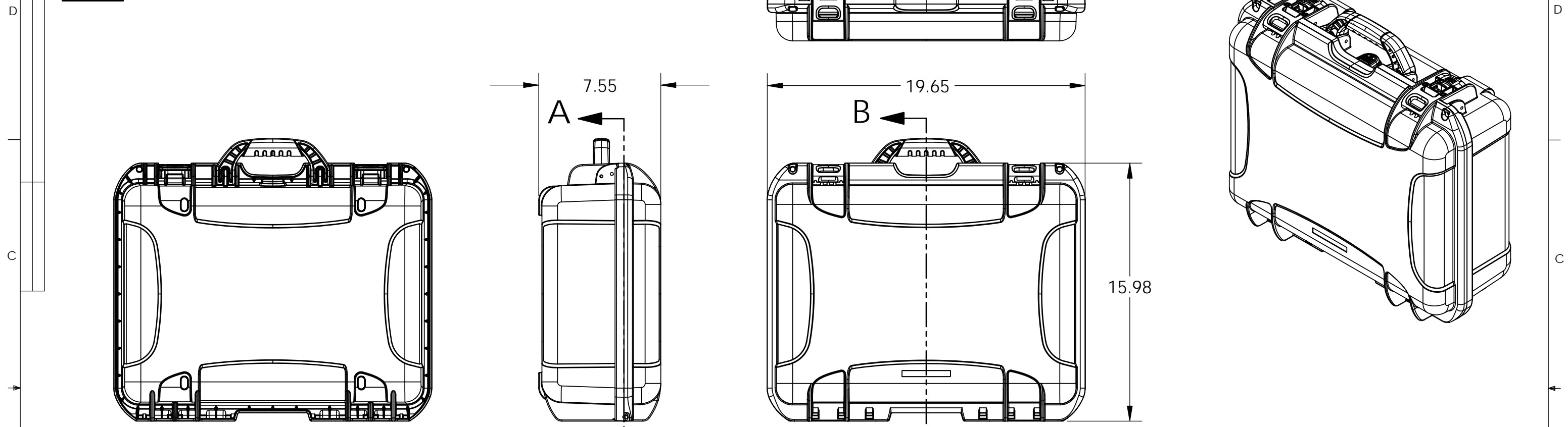

SECTION B-B

NANUK 930 Specifications	
Case Weight Empty	7.1lbs / 3.2kg
Interior Length	18.06" / 459mm
Interior Width	13.08" / 332mm
Interior Height	6.99" / 178mm
Interior Lid Depth	2.11" / 54mm
Interior Base Depth	4.89" / 124mm
Exterior Length	19.65" / 499mm
Exterior Width	15.98" / 406mm
Exterior Height	7.55" / 192mm
Master Pack Qty.	3
Master Pack Wt.	27.8lbs / 12.61kg
Max Buoyancy	65lbs / 29.48kg

PARTS LIST			
UNLESS OTHERWISE SPECIFIED DIMENSIONS ARE IN INCHES	CAD GENERATED DRAWING, DO NOT MANUALLY UPDATE		PLASTICASE NANUK 930
	APPROVALS	DATE	
	DRAWN B.C.	6/30/2011	
	CHECKED		
MATERIAL	RESP ENG		SIZE B DWG. NO. REV.
FINISH --	MFG ENG		
DO NOT SCALE DRAWING	QUAL ENG		
SCALE 1:6		CAD FILE: 930_ASSEMBLY	SHEET 1 OF 1