



plasticase

# NANUK

PROFESSIONAL PROTECTIVE CASES



INSTRUMENTS  
**TECHNO  
TEST**

## NANUK™ 910 DJI™ Osmo



### The **NANUK** CASE **ADVANTAGE** |

**Powerclaw latching system • Waterproof (IP67 rated) • Impact resistant NK-7 resin • Available in 8 COLORS • LIFETIME GUARANTEE**

Système de fermeture Powerclaw • Étanche (certifié IP67) • Résine NK-7 résistante aux chocs • Disponible dans 8 couleurs • Garantie à vie  
Sistema de enclavamiento Powerclaw • Impermeable (IP67 certificado) • Resina NK-7 resistente al impacto • Disponible en 8 colores • Garantía de por vida

**\*DJI Osmo not included.**

\*DJI Osmo per inclus \*DJI Osmo no incluido.

# NANUK™ 910 DJI™ Osmo



## 1. Osmo

## 2. Charger

Chargeur

Cargador

## 3. Batteries (x3)

Piles (x3)

Baterías (x3)

## 4. Shoulder Strap

Bandoulière

Bandolera

## 5. Smart Phone cavity

Emplacement pour téléphone intelligent

Ubicación para teléfono inteligente

## 6. AC Cable and accessories

Câble AC et accessoires

Cable y accesorios

## 7. Instructions manual

Manuel d'instructions

Manual de Instrucciones

## Available options

Options disponibles

Opciones disponibles

## TSA Padlock

Cadenas à combinaison TSA

Candado TSA



## Shoulder Strap

Bandoulière

Bandolera



## Dimensions | Dimensions | Dimensiones

### Exterior | Extérieure | Exteriore

L14.3" x W11.1" x H4.7" | L363mm x W282mm x H120mm

### Interior | Intérieure | Interiore

L13.2" x W9.2" x H4.1" | L336mm x W234mm x H104mm

### Weight (with foam) | Poids (avec la mousse) | Peso (con espuma)

3.5 lbs | 1.6 kg

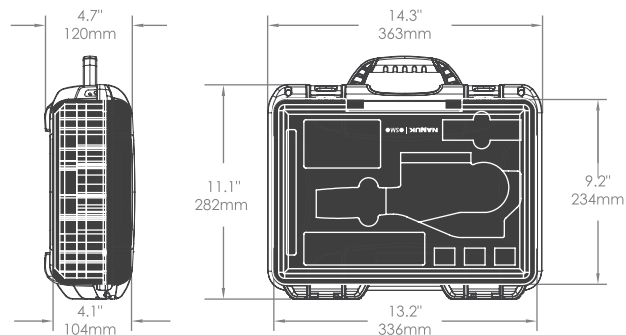

## Available colors | Couleurs disponibles | Colores disponibles

Black  
Noir  
Negro



Graphite  
Graphite  
Grafito



Lime  
Lime  
Lima



Olive  
Olive  
Oliva



Orange  
Orange  
Naranja



Silver  
Argent  
Plata



Tan  
Beige  
Beige



Yellow  
Jaune  
Amarillo

