

THE INFORMATION CONTAINED IN THIS DRAWING IS THE SOLE PROPERTY OF PLASTICASE ANY REPRODUCTION IN PART OR WHOLE WITHOUT THE WRITTEN PERMISSION OF PLASTICASE IS PROHIBITED.

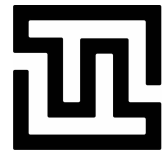

**INSTRUMENTS  
TECHNO  
TEST**

REVISIONS			
REV.	DESCRIPTION	DATE	APPROVED

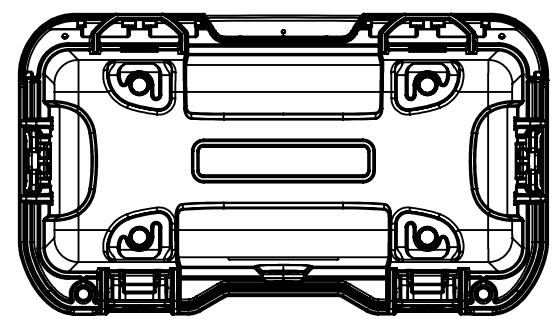
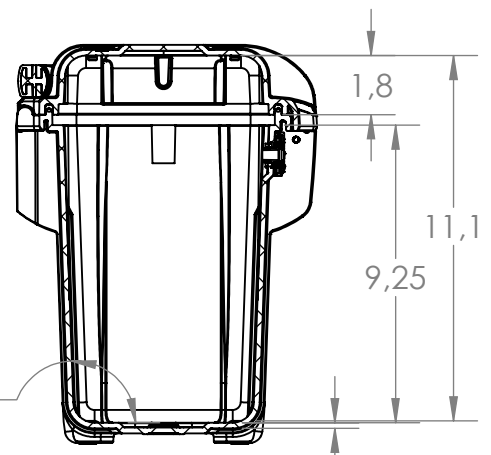
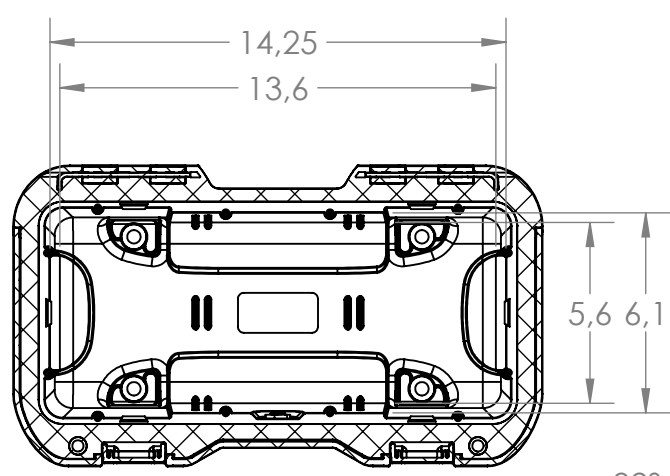
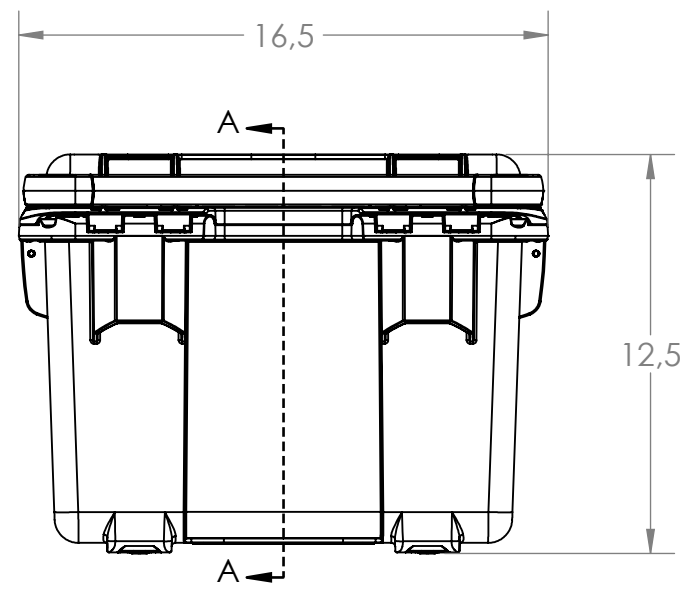
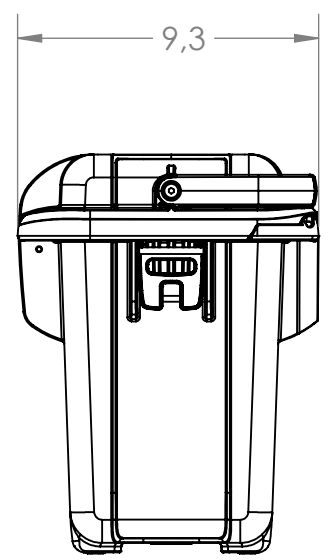
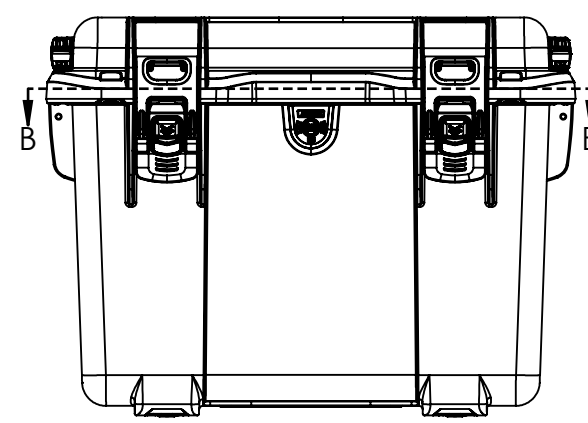

NANUK T30 Specifications	
<b>Case Weight Empty</b>	5.83lbs / 2.65kg
<b>Interior Length</b>	14.25" / 362 mm
<b>Interior Width</b>	6.1" / 155 mm
<b>Interior Height</b>	11.1" / 282mm
<b>Interior Lid Depth</b>	1.8" / 46 mm
<b>Interior Base Depth</b>	9.25" / 235 mm
<b>Exterior Length</b>	16.5" / 419 mm
<b>Exterior Width</b>	9.3" / 236 mm
<b>Exterior Height</b>	12.5" / 317 mm
<b>Master Pack Qty.</b>	TBD
<b>Master Pack Wt.</b>	TBD
<b>Max Buoyancy</b>	51lbs / 23.5kg

UNLESS OTHERWISE SPECIFIED DIMENSIONS ARE IN INCHES [mm]

MATERIAL

FINISH --

DO NOT SCALE DRAWING

CAD GENERATED DRAWING, DO NOT MANUALLY UPDATE

APPROVALS	DATE
DRAWN D.B.	2024-08-06
CHECKED	
RESP ENG	
MFG ENG	
QUAL ENG	

**NANUK GEAR PROTECTION**

**NANUK T30**

SIZE B	DWG. NO.	REV.
SCALE 1:6	CAD FILE: Main Assy T30_p.00	SHEET 1 OF 1

.2 WALL THICKNESS