

THE INFORMATION CONTAINED IN THIS DRAWING IS THE SOLE PROPERTY OF PLASTICASE ANY REPRODUCTION IN PART OR WHOLE WITHOUT THE WRITTEN PERMISSION OF PLASTICASE IS PROHIBITED.

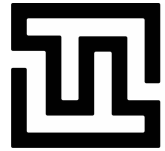

**INSTRUMENTS  
TECHNO  
TEST**

REVISIONS			
REV.	DESCRIPTION	DATE	APPROVED

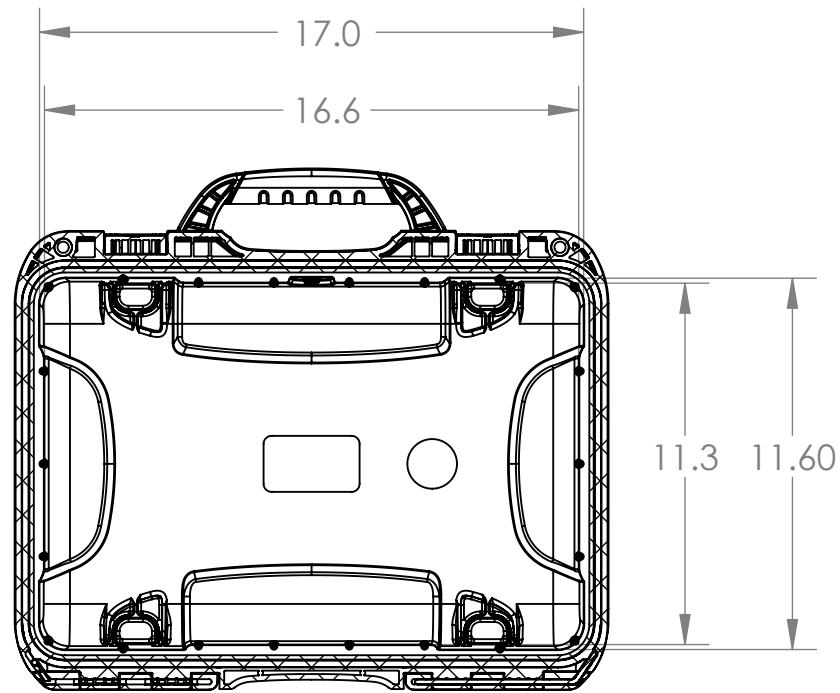
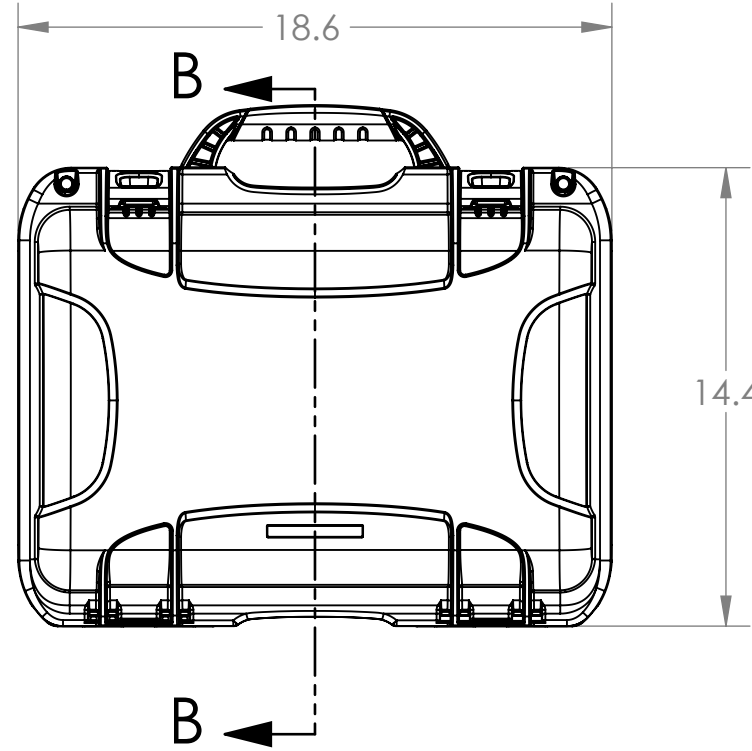
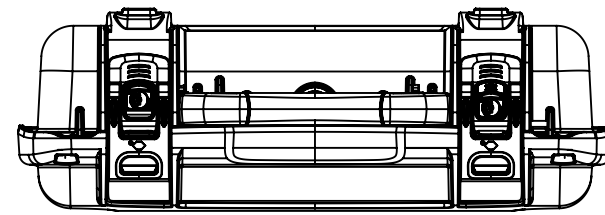
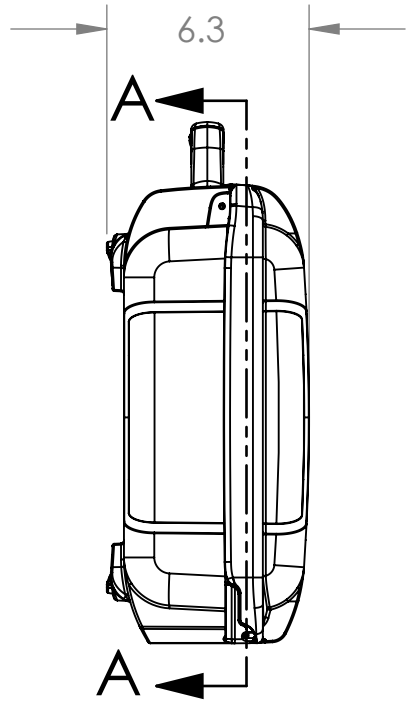
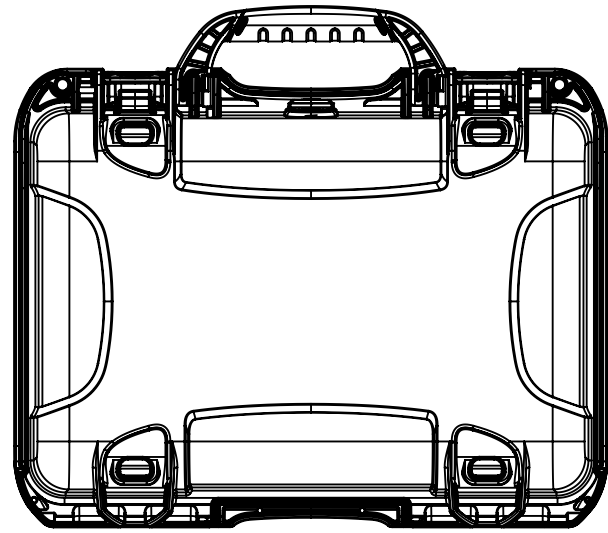

SECTION A-A

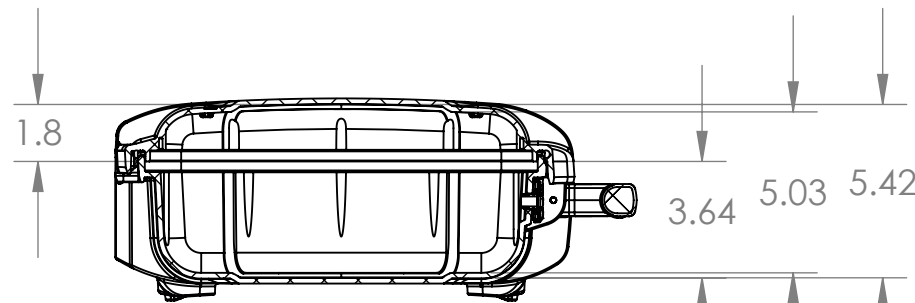

SECTION B-B

**NANUK 923 Specifications**

Case Weight Empty	5.9lbs / 2.7kg
Interior Length	16.6" / 422 mm
Interior Width	11.3" / 287 mm
Interior Height	5.4" / 137mm
Interior Lid Depth	1.8" / 46 mm
Interior Base Depth	3.6" / 91 mm
Exterior Length	18.6" / 472 mm
Exterior Width	14.4" / 366 mm
Exterior Height	6.3" / 160 mm
Master Pack Qty.	1
Master Pack Wt.	TBD
Max Buoyancy	TBD

PARTS LIST

UNLESS OTHERWISE SPECIFIED  
DIMENSIONS ARE IN INCHES

CAD GENERATED DRAWING,  
DO NOT MANUALLY UPDATE

PLASTICASE

APPROVALS  
DRAWN B.C.

DATE  
03/11/2016

NANUK 923

CHECKED  
RESP ENG

FINISH --  
MFG ENG

QUAL ENG

SIZE B DWG. NO. REV.

DO NOT SCALE DRAWING

SCALE 1:6 CAD FILE: 923\_Assembly SHEET 1 OF 1