

THE INFORMATION CONTAINED IN THIS DRAWING IS THE SOLE PROPERTY OF PLASTICASE ANY REPRODUCTION IN PART OR WHOLE WITHOUT THE WRITTEN PERMISSION OF PLASTICASE IS PROHIBITED.

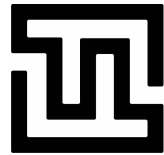

INSTRUMENTS  
**TECHNO  
TEST**

REVISIONS			
REV.	DESCRIPTION	DATE	APPROVED

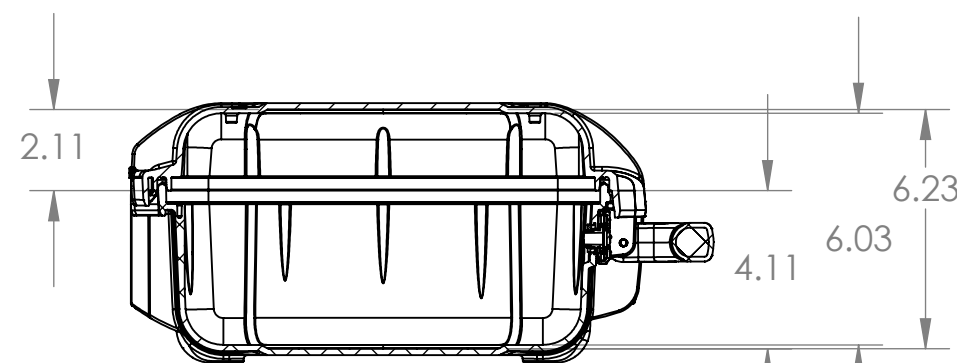
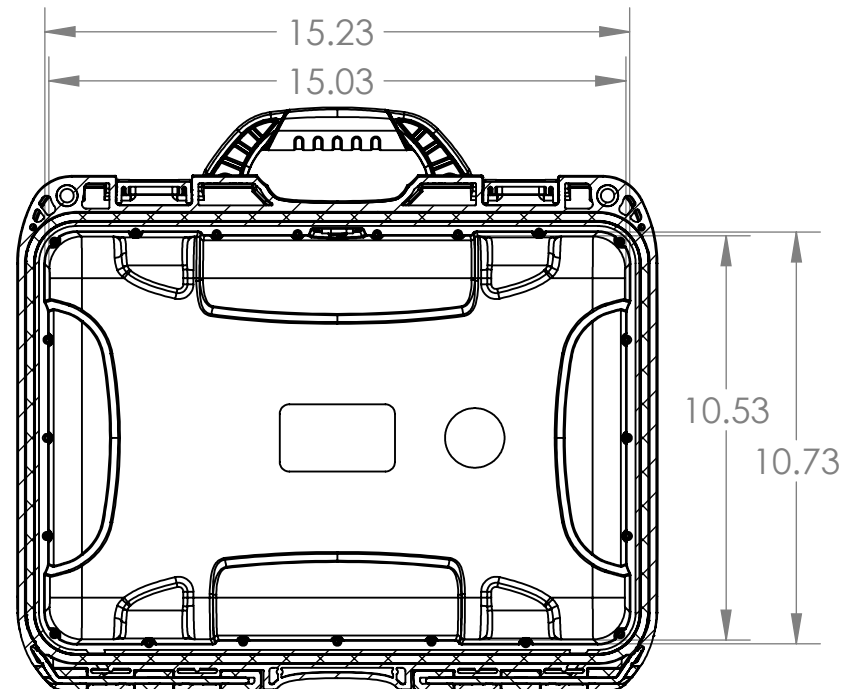
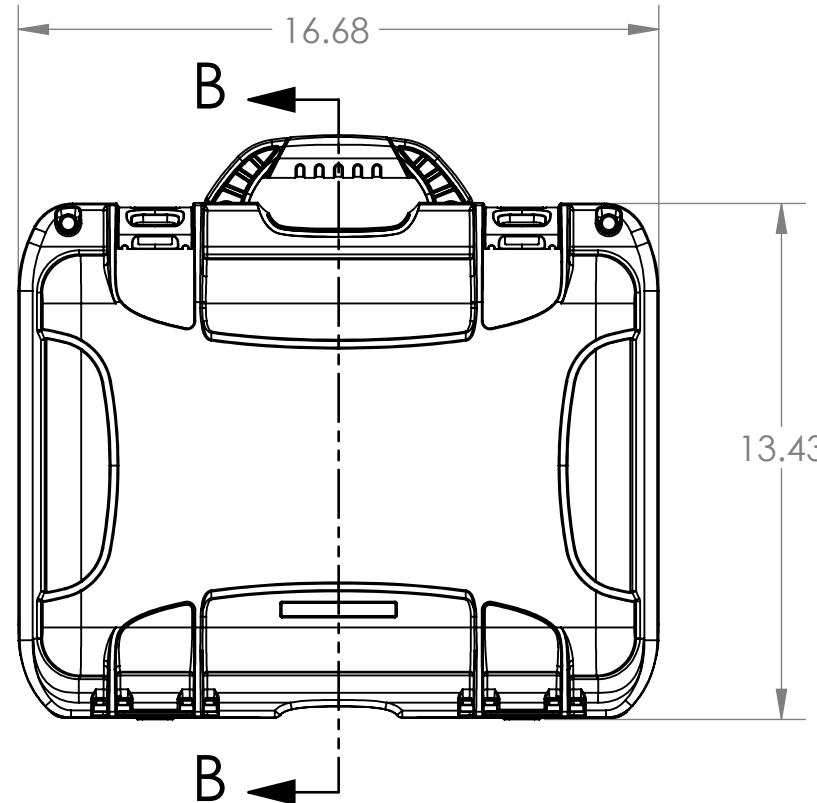
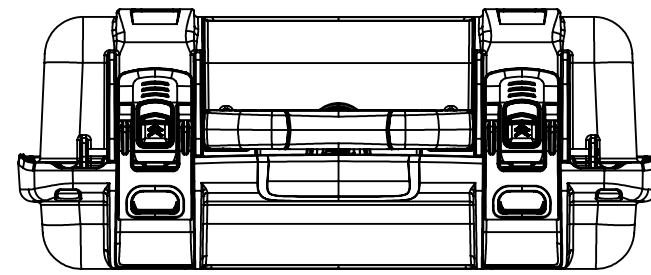
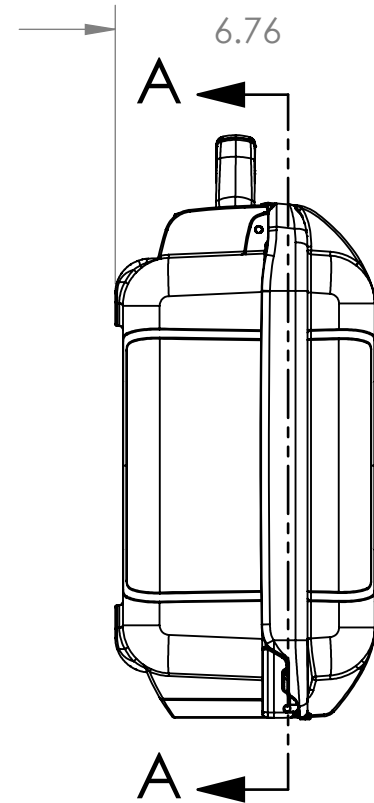
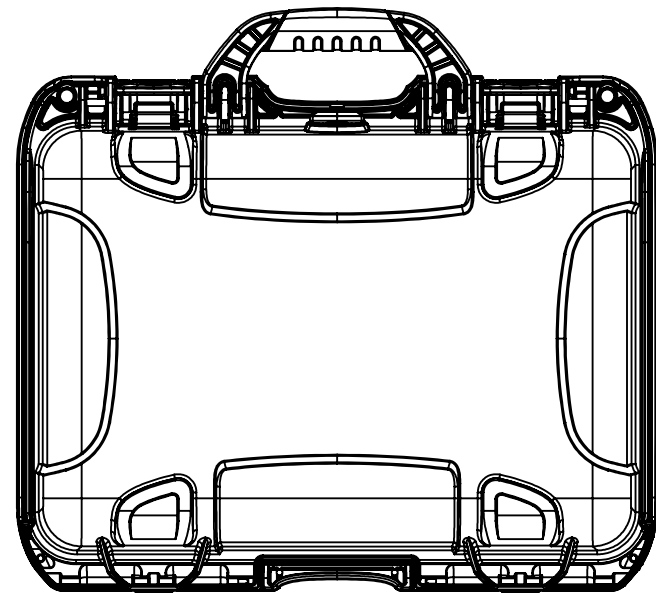

NANUK 920 Specifications	
Case Weight Empty	5.0lbs / 2.3kg
Interior Length	15.03" / 381mm
Interior Width	10.53" / 267mm
Interior Height	6.23" / 157mm
Interior Lid Depth	2.11" / 53mm
Interior Base Depth	4.11" / 104mm
Exterior Length	16.68" / 424mm
Exterior Width	13.43" / 340mm
Exterior Height	6.76" / 173mm
Master Pack Qty.	4
Master Pack Wt.	28.5lbs / 12.93kg
Max Buoyancy	40lbs / 18.14kg

SECTION A-A

SECTION B-B

PARTS LIST			
UNLESS OTHERWISE SPECIFIED DIMENSIONS ARE IN INCHES		CAD GENERATED DRAWING, DO NOT MANUALLY UPDATE	
APPROVALS		DATE	
DRAWN	S.C.	04/03/2020	
CHECKED			
RESP ENG			
MFG ENG			
QUAL ENG			
DO NOT SCALE DRAWING			
		PLASTICASE	
		NANUK 920_R1	
SIZE	DWG. NO.	REV.	
B			
SCALE	CAD FILE:	SHEET 1 OF 1	
1:5	920_R1_ASSEMBLY_p.00		