

THE INFORMATION CONTAINED IN THIS DRAWING IS THE SOLE PROPERTY OF PLASTICASE ANY REPRODUCTION IN PART OR WHOLE WITHOUT THE WRITTEN PERMISSION OF PLASTICASE IS PROHIBITED.

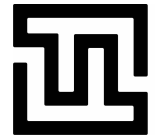

**INSTRUMENTS  
TECHNO  
TEST**

REVISIONS			
REV.	DESCRIPTION	DATE	APPROVED

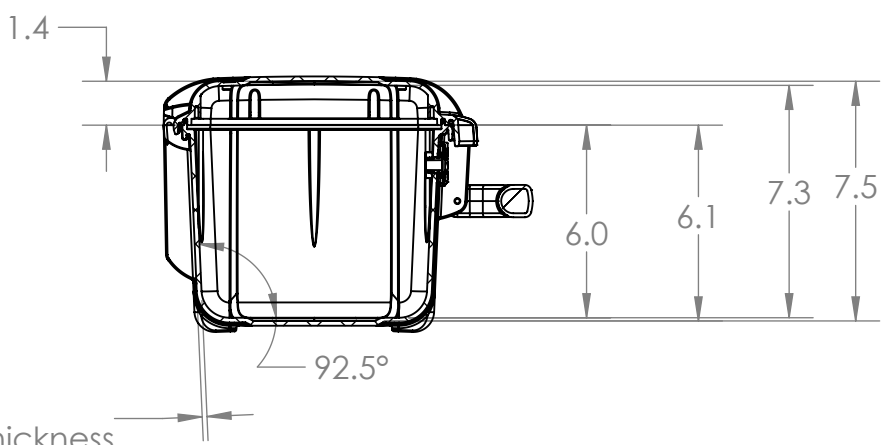
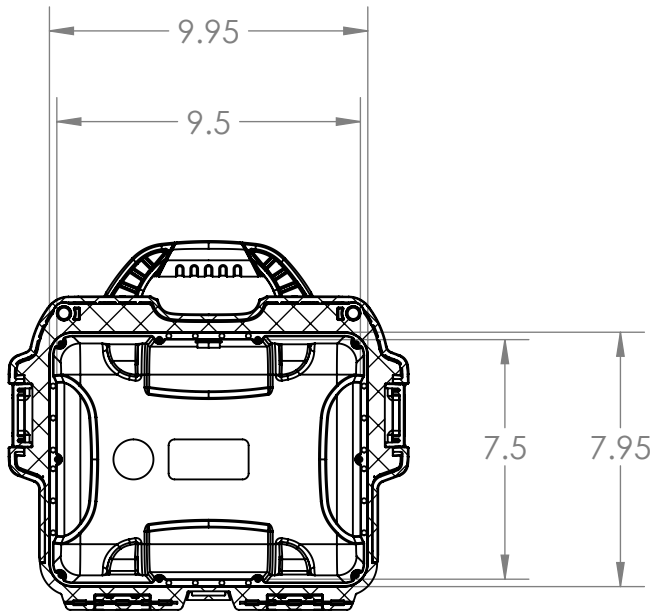
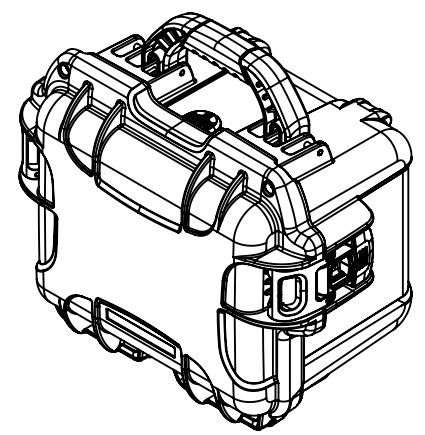
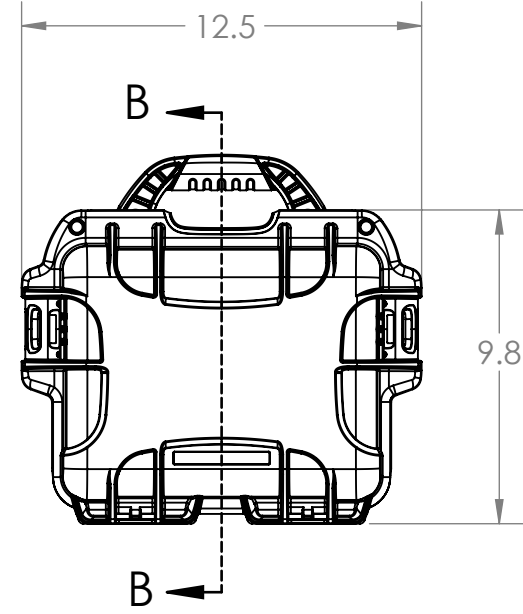
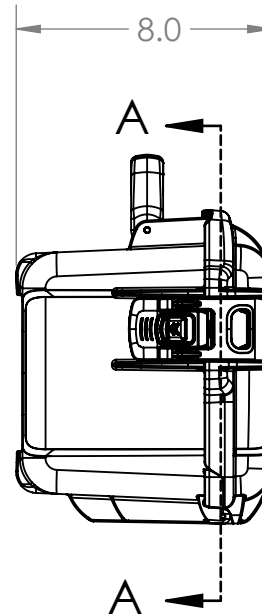
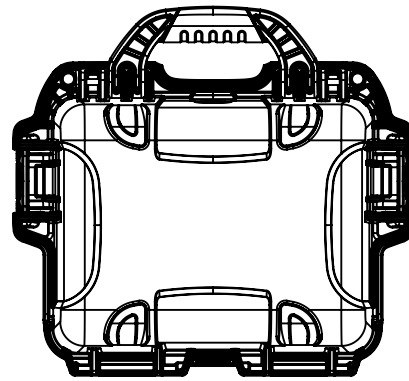

NANUK 908 Specifications	
Case Weight Empty	3.2lbs / 1.47kg
Interior Length	9.5" / 241 mm
Interior Width	7.5" / 191 mm
Interior Height	7.5" / 191mm
Interior Lid Depth	1.4" / 36 mm
Interior Base Depth	6.1" / 155 mm
Exterior Length	12.5" / 318 mm
Exterior Width	9.8" / 249 mm
Exterior Height	8.0" / 203 mm
Master Pack Qty.	4
Master Pack Wt.	16.6lbs / 7.5kg
Max Buoyancy	18lbs / 8.2kg

SECTION A-A

SECTION B-B

PARTS LIST			
UNLESS OTHERWISE SPECIFIED DIMENSIONS ARE IN INCHES [mm]	CAD GENERATED DRAWING, DO NOT MANUALLY UPDATE		PLASTICASE
	APPROVALS	DATE	
	DRAWN B.C.	8/2/2017	
	CHECKED		
MATERIAL	RESP ENG	NANUK 908	REV.
FINISH --	MFG ENG		
DO NOT SCALE DRAWING	QUAL ENG		
SIZE B	DWG. NO.	SCALE 1:6	CAD FILE: 908_ASSEMBLY
SHEET 1 OF 1			