

THE INFORMATION CONTAINED IN THIS DRAWING IS THE SOLE PROPERTY OF PLASTICASE ANY REPRODUCTION IN PART OR WHOLE WITHOUT THE WRITTEN PERMISSION OF PLASTICASE IS PROHIBITED.

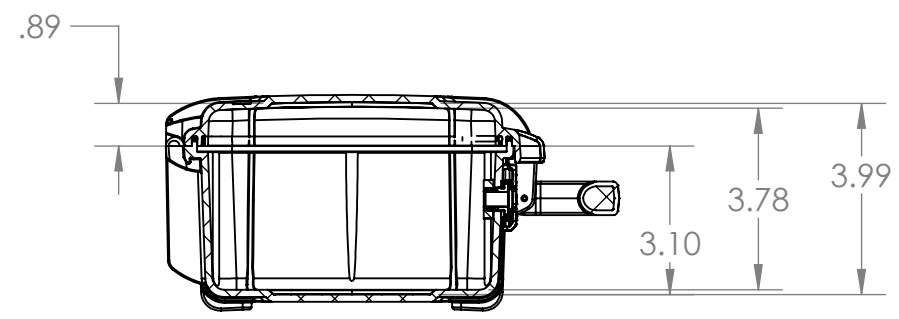

REVISIONS			
REV.	DESCRIPTION	DATE	APPROVED

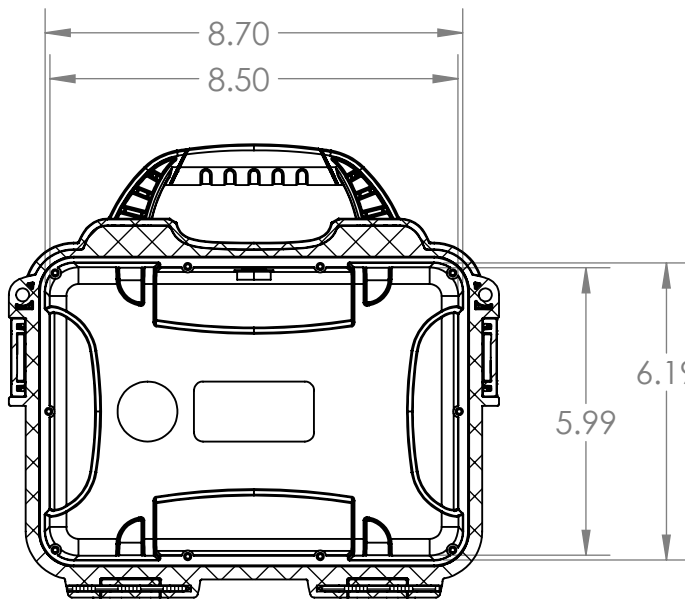
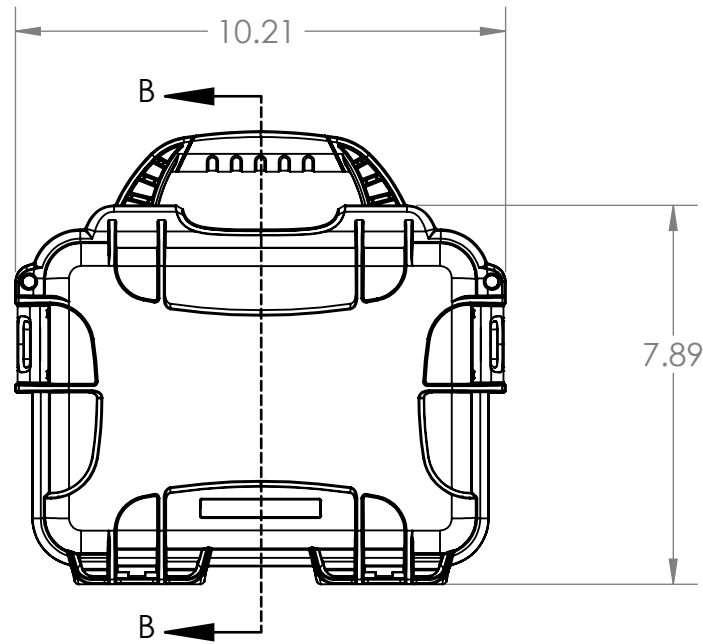
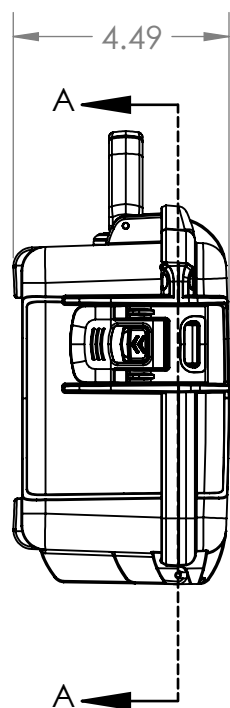
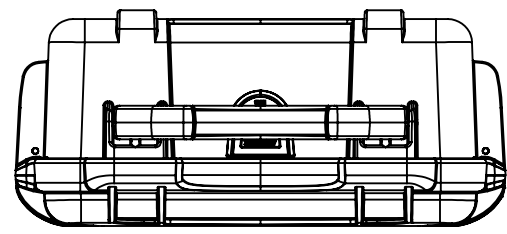
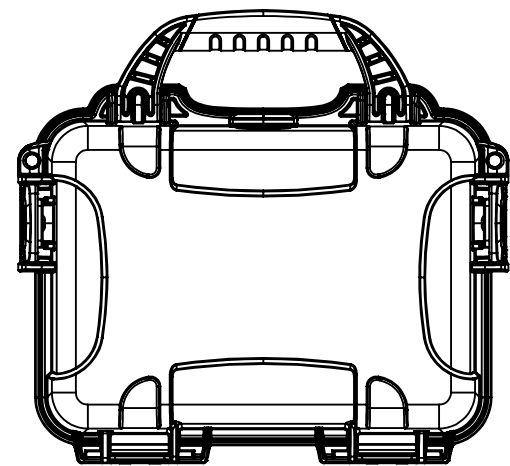

NANUK 904 Specifications	
Case Weight Empty	1.6lbs / 0.7kg
Interior Length	8.50" / 216mm
Interior Width	5.99" / 152mm
Interior Height	3.99" / 101mm
Interior Lid Depth	0.89" / 23mm
Interior Base Depth	3.10" / 79mm
Exterior Length	10.21" / 259mm
Exterior Width	7.89" / 200mm
Exterior Height	4.49" / 114mm
Master Pack Qty.	10
Master Pack Wt.	20.30lbs / 9.40kg
Max Buoyancy	7.28lbs / 3.30kg

PARTS LIST			
UNLESS OTHERWISE SPECIFIED DIMENSIONS ARE IN INCHES	CAD GENERATED DRAWING, DO NOT MANUALLY UPDATE		PLASTICASE
	APPROVALS	DATE	
MATERIAL	DRAWN	P.L.O.	NANUK 904
	CHECKED		
FINISH	RESP ENG		SIZE B
	MFG ENG		
DO NOT SCALE DRAWING	QUAL ENG		DWG. NO.
SCALE 1:4		CAD FILE: 904_ASSEMBLY_Curve	REV. SHEET 1 OF 1