

THE INFORMATION CONTAINED IN THIS DRAWING IS THE SOLE PROPERTY OF PLASTICASE ANY REPRODUCTION IN PART OR WHOLE WITHOUT THE WRITTEN PERMISSION OF PLASTICASE IS PROHIBITED.

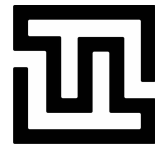

INSTRUMENTS
**TECHNO
TEST**

REVISIONS			
REV.	DESCRIPTION	DATE	APPROVED

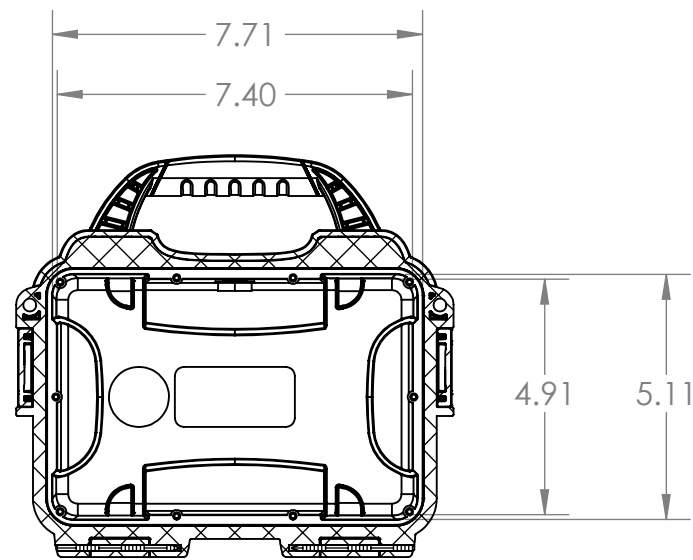
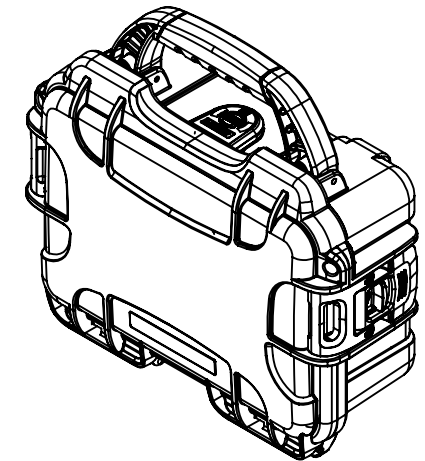
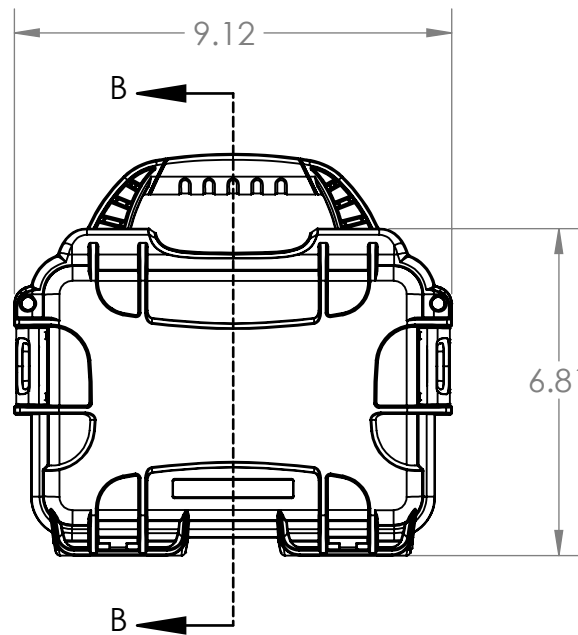
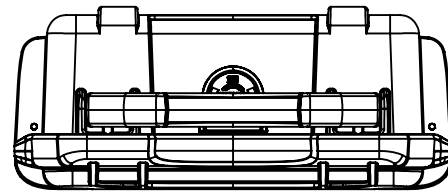
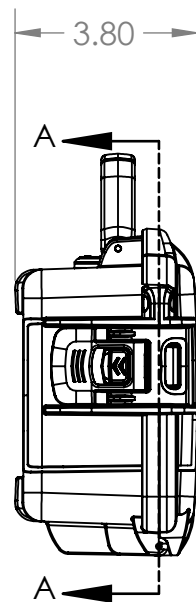
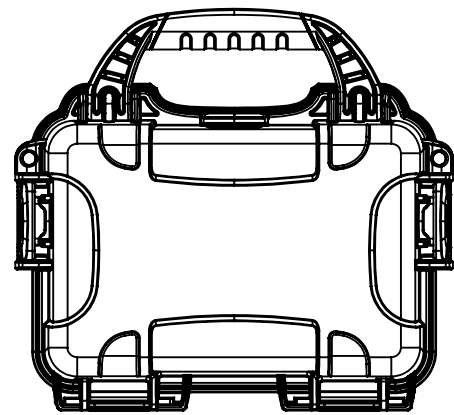

SECTION A-A

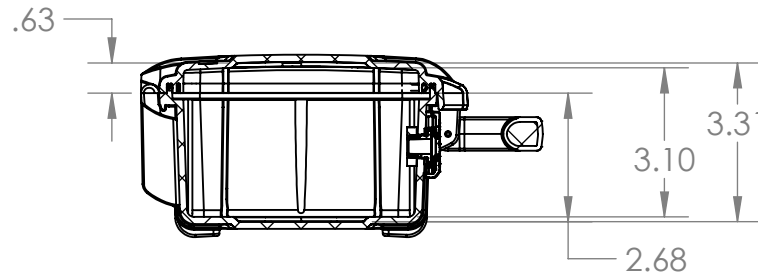

SECTION B-B

NANUK 903 Specifications

Case Weight Empty	1.3lbs / 0.6kg
Interior Length	7.40" / 188mm
Interior Width	4.91" / 125mm
Interior Height	3.31" / 84mm
Interior Lid Depth	0.63" / 16mm
Interior Base Depth	2.68" / 68mm
Exterior Length	9.12" / 232mm
Exterior Width	6.81" / 173mm
Exterior Height	3.80" / 97mm
Master Pack Qty.	10
Master Pack Wt.	16.05lbs / 7.28kg
Max Buoyancy	N/A

PARTS LIST

UNLESS OTHERWISE SPECIFIED DIMENSIONS ARE IN INCHES	CAD GENERATED DRAWING, DO NOT MANUALLY UPDATE		PLASTICASE
	APPROVALS	DATE	
	DRAWN P.L.O.	25/10/2013	
	CHECKED		
MATERIAL	RESP ENG		NANUK 903
FINISH --	MFG ENG		
DO NOT SCALE DRAWING	QUAL ENG		
	SIZE B	DWG. NO.	REV.
	SCALE 1:4	CAD FILE: 903_ASSEMBLY_Curve_REV\$SHEET 1 OF 1	