

INSTRUCTION MANUAL

SME SERIES

HANDY DATA LOGGER

Thank you for purchasing KYOWA's product Handy Data Logger SME series.
Read this Instruction Manual carefully in order to make full use of the high performance capabilities of the product.
Do not use the product in methods other than described in this Manual.

Generally, company names and trade names described in this Instruction Manual are trademarks or registered trademarks of the companies.

This Instruction Manual may not be copied or reproduced, in whole or part, without consent of KYOWA.

Copyright © KYOWA ELECTRONIC INSTRUMENTS CO., LTD. All rights reserved.

The contents of the Instruction Manual are subjected to change without prior notice.

-CONTENTS-

STANDARD ACCESSORIES.....	- 1 -
OPTIONS.....	- 1 -
SAFETY PRECAUTIONS	- 1 -
PRIOR TO USE	- 1 -
SAFETY SYMBOLS.....	- 1 -
NOTATIONS USED IN INSTRUCTION MANUAL	- 3 -
INFORMATIONAL NOTES.....	- 3 -
QUOTATIONS.....	- 3 -
IMPORTANT PRECAUTIONS WHEN USING SME SERIES.....	- 3 -
1. OUTLINE OF SME SERIES.....	- 4 -
1-1. OUTLINE OF SME SERIES.....	- 4 -
1-2. SYSTEM CONFIGURATION.....	- 5 -
2. PARTS AND FUNCTIONS.....	- 7 -
2-1. DESCRIPTION OF OPERATION PANEL.....	- 7 -
2-2. DESCRIPTION OF DISPLAY	- 8 -
3. HOW TO USE.....	- 11 -
3-1. BEFORE USING.....	- 11 -
3-2. INSERTING DRY CELL	- 11 -
3-3. INSERTING AND REMOVING SD CARD	- 12 -
3-4. POWER ON/OFF	- 13 -
3-5. INPUT SETTING.....	- 14 -
3-6. SENSOR CONNECTION.....	- 15 -
3-7. SAVING DATA.....	- 17 -
4. MEASUREMENT WITH NTB SERIES CONNECTED	- 19 -
5. MEASUREMENT WITH SMET-1A CONNECTED.....	- 21 -
5-1. REMOVING/REATTACHING D-SUB COVER.....	- 22 -
5-2. CONNECTING/DISCONNECTING SMET-1A	- 24 -
5-3. CONNECTING/DISCONNECTING THERMOCOUPLE.....	- 26 -
5-4. MEASURING TEMPERATURE BY USING A THERMOCOUPLE	- 28 -
5-5. BURNOUT CHECKING	- 29 -
6. USEFUL FUNCTIONS	- 31 -
6-1. OPERATION MODE OF SME SERIES	- 31 -
6-2. RESISTANCE VALUE CHECKING	- 33 -
6-3. INSULATION CHECKING	- 34 -
6-4. AUTO POWER OFF FUNCTION	- 35 -
6-5. RELATIVE VALUE MEASUREMENT	- 37 -
6-6. CALC. CAL COEF.(FOR DISPLAYING PHYSICAL QUANTITY)	- 39 -
6-7. READING/WRITING TEDS INFORMATION	- 41 -
6-8. INTERVAL MEASUREMENT.....	- 43 -
6-9. FILE OPERATION.....	- 45 -
6-10. FILE INCREMENT SETTING	- 51 -
6-11. SWITCHING REFERENCE JUNCTION COMPENSATION.....	- 52 -

7. MENU LIST.....	- 55 -
8. TROUBLE SHOOTING	- 56 -
9. SPECIFICATIONS.....	- 57 -
HANDY DATA LOGGER: SME—30A/31A.....	- 57 -
HANDY DATA LOGGER: SME—100A/101A.....	- 59 -
THERMOCOUPLE ADAPTER FOR SME: SMET-1A.....	- 61 -
10. OUTSIDE DRAWING.....	- 62 -

STANDARD ACCESSORIES

The Handy Data Logger SME series (hereinafter referred to as the SME series) and SMET-1A Thermocouple Adapter for SME (hereinafter referred to as the SMET-1A) come with the following accessories. When unpacking, check the contents to ensure that all accessories are enclosed.

	SME-30A/31A	SME-100A/101A	SMET-1A (optional)
CD-R (Instruction Manual: This file)	1	1	1
Input Cable	1	1	————
Size AA Alkaline Dry Cell	2	2	————
Communication Cable N-102 (Length: Approx. 1 m)	————	1	————
Term and Conditions of Product Warranty	1	1	1
Shoulder Strap	1	1	————
Wrist Strap	1	1	————
Tape for dry cell cover	1	1	————
Mounting screw	————	————	2

OPTIONS

AC Adapter (for 100 VAC, usable with the SME-31A and SME-101A)	:	SW-0522E
NTB-100A series, and NTB-201A	:	Refer to the NTB catalog.
SMET-1A	:	Refer to this file.

SAFETY PRECAUTIONS

The SME series and SMET-1A are designed in accordance with “9. SPECIFICATIONS.”

Do not use the SME series and SMET-1A in an environment exceeding the specifications. Or, failure of the SME series and SMET-1A may result.



PRIOR TO USE

For safe use of the SME series and SMET-1A, do not forget to read the <Safety Precautions> prior to use.

Kyowa Electronic Instruments Co., Ltd. assumes no liability for any damages resulting from user’s failure to comply with the safety precautions.

SAFETY SYMBOLS

For safety operation of the SME series and SMET-1A, the following symbol marks are used in the Instruction Manual.

 WARNING	Improper operation of the system may result in death or severe injury of the operator.
 CAUTION	Improper operation of the system may result in injury of the operator and physical damage of the system.

WARNING

- Do not short-circuit positive (+) and negative (-) terminals of the dry cell.
Or, it may produce fever or ignite due to a rush current.
- Do not heat or throw into fire.
Or, it may produce fever, ignite or explode.
- Correctly insert dry cells.
- If liquid leaking from the dry cell gets into your eyes, do not rub your eyes.
- Wash them well with clean water and consult with a doctor.
- If any liquid from the dry cell comes in contact with your skin, wash quickly with water.
- Do not recharge the alkaline dry cells since the AA size alkaline dry cells are primary dry cells.
- When using the AC adapter with the SME series compatible to the AC adapter, check the power voltage of the outlet before connecting.
- Avoid using in environment with inflammable gas, etc.
To prevent the risk of fire hazard or explosion, do not use the SME series and SMET-1A in environment with inflammable gas, vapor or dust.
- If any trouble occurs.
To prevent a fire hazard, if smoke is emitted from the SME series or SMET-1A, immediately stop using the SME series and SMET-1A.
When using the AC adapter, disconnect the AC adapter from the receptacle.
- Avoid measuring objects applied with high voltage.

CAUTION

- Use the SME series and SMET-1A in the specified operating temperature range 10 to 50°C.
Use at temperatures exceeding the specified range may lower the performance and cause troubles.
If use under direct sunlight or in a cold place is inevitable, prepare a sunscreen or take proper measures to keep it warm.
- Use the SME series and SMET-1A in the specified operating humidity range 20 to 85%.
Use in a humid place exceeding the specified range or where it is exposed to splashing water may lower the performance and cause troubles.
- Immediately stop the SME series and SMET-1A if operating environment changes abruptly.
Leave the SME series and SMET-1A as it is until it becomes adaptable to the environment.
Abrupt change in ambient temperature due to transportation, etc. may cause dew condensation result to deteriorate its performance and cause troubles.
- Do not use the SME series and SMET-1A in strong electromagnetic field.
Use the SME series in a magnetic field environment where the PC may be used.
If the SME series and SMET-1A are used near devices generating strong magnetic field such as a telemetry system, microwave oven, electric furnace, etc., its performance may be lowered and erroneous operation and trouble may result.
- Do not pull cords and cables.
Lay cords and cables with a certain allowance so that unreasonable force is applied to the connections.
Pulling or applying unreasonable force may cause trouble or interrupt the measurement.

NOTATIONS USED IN INSTRUCTION MANUAL

INFORMATIONAL NOTES

Certain notations are used as necessary to attract your attention to information that requires special care when handling the SME series and SMET-1A, and to information provided for reference purposes.

Examples of Notations

NOTE

Essential precautions required when handling the SME series and SMET-1A.

MEMO

Reference items required when handling the SME series and SMET-1A.

QUOTATIONS

Operation keys are enclosed as follows.

Example: ENTER key

Names described on the panel surface are expressed in angled bracket (< >). (Excluding menu)

Example: <ON>

IMPORTANT PRECAUTIONS WHEN USING SME SERIES

NOTE

1. Do not take off the batteries during saving the data.
If the power is forcibly turned OFF during saving the data, recording data may lead to invalid.
2. Do not use solvent such as thinner for cleaning.
To clean the case, dip a soft cloth to a neutral detergent and twist it tightly.
If the solvent such as thinner is used, the case or panel may melt or be discolored.
3. Do not press on the LCD screen.
Do not puncture the LCD screen by an object with a fine head such as ballpoint pen.
Or, it may cause trouble.
4. Do not insert foreign matters to a SD card slot.
Or, it may cause trouble.
5. Do not insert foreign matters or water to a dry cell place.
6. The SME series is not waterproof.
After the water is attached, sufficiently clean with a dry and clean cloth and dry the SME series before using.
7. When not using the SME series for a long time, remove dry cells from the SME series.

1. OUTLINE OF SME SERIES

1-1. OUTLINE OF SME SERIES

The SME series is a measuring apparatus for a strain gage or strain gage transducer.

Capable of measuring strain easily with the accessory input cable since the SME series incorporates a bridge box.

Power is supplied by AA size alkaline dry cells (×2).

Capable of saving the measured data in a commercially available SD card.

The SME-100A/101A can be used for checking the operation of an optional Network Terminal Box NTB-100A series/NTB-201A (hereinafter referred to as the NTB). Furthermore, the SME-100A/101A can also measure up to 33-CH by connecting the multiple NTB units.

An optional AC adapter can be used with the SME-31A/101A.

For measuring a temperature by using a thermocouple, use an optional SMET-1A with the SME series.

NOTE

SDHC cards is not available.

[SME series]

Model	Measurement with the NTB	Usage of AC adapter	Measurement with the SMET-1A
SME-30A			✓
SME-31A		✓	✓
SME-100A	✓		✓
SME-101A	✓	✓	✓

Note: ✓ : Available

1-2. SYSTEM CONFIGURATION

(1) SME-30A/31A

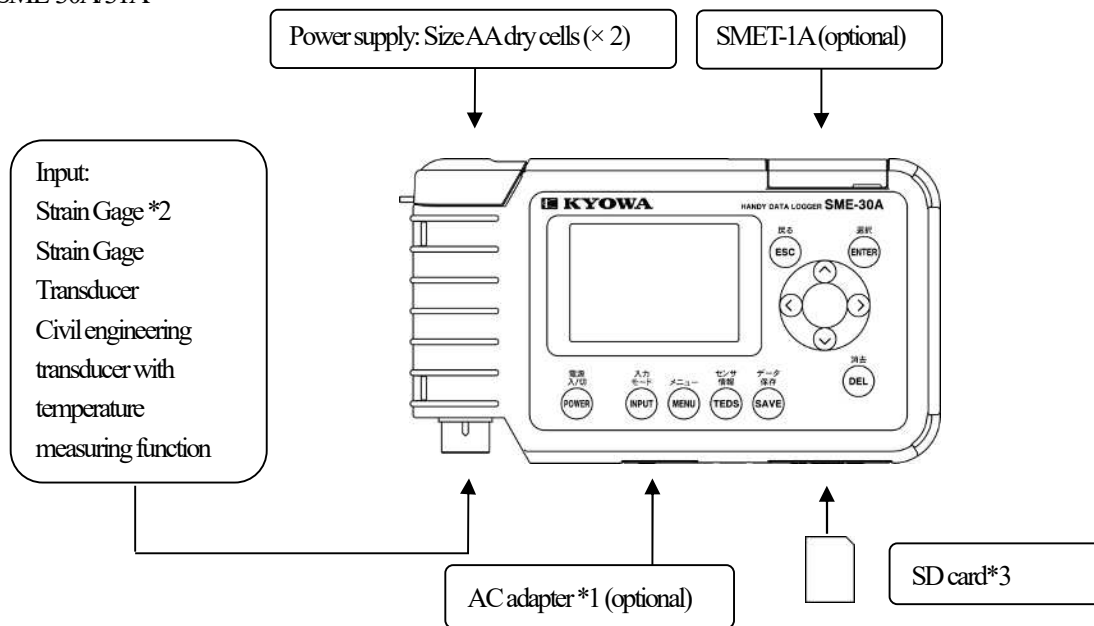

*1: Only the SME-31A can use the AC adapter.

*2: For measuring a strain gage, use the accessory input cable.

*3: The SD card is not included inside the package. You need to purchase a commercial product.
SDHC cards is not available.

(2) SME-100A/101A

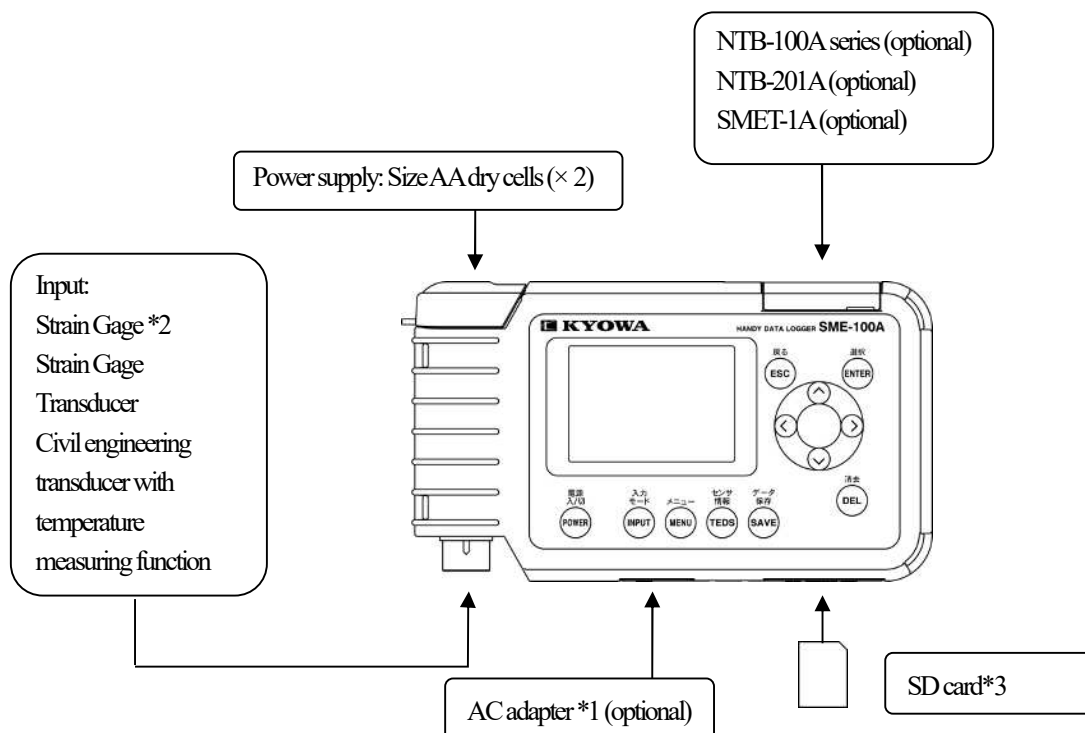

*1: Only the SME-101A can use the AC adapter.

*2: For measuring a strain gage, use the accessory input cable.

*3: The SD card is not included inside the package. You need to purchase a commercial product.
SDHC cards is not available.

(Blank page)

2. PARTS AND FUNCTIONS

2-1. DESCRIPTION OF OPERATION PANEL

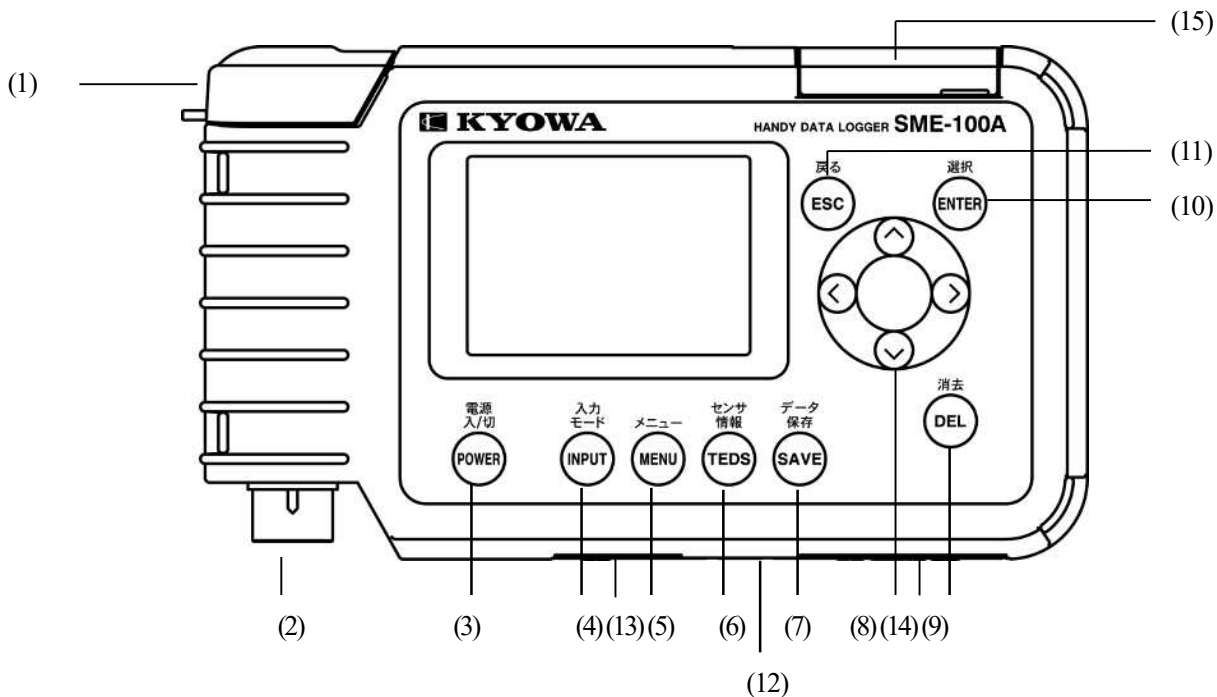

(1) Dry cell cover: For mounting and dismounting, slide the cover with pressing. Be sure not to dismount the cover carelessly.

(2) Input connector: Directly connect a sensor with a NDIS connector or connect the input cable for measurement.

(3) **POWER** key: POWER ON/OFF For turning ON the power, keep pressing for about 3 seconds.
For turning OFF the power, press for about 1 second.

(4) **INPUT** key: Displays input modes.
Used for selecting the target mode compatible to the sensor.

(5) **MENU** key: Displays a detailed menu. Used for coefficient calculation, interval measurement, etc.

(6) **TEDS** key: Displays a menu related to TEDS. Used for reading TEDS information.

(7) **SAVE** key: For saving the set value in the SD card.

(8) Cursor key: Used for moving a cursor or switching a menu.

(9) **DEL** key: Used for selecting a file to be deleted or default setting.

(10) **ENTER** key: Used for determining a setting content.

(11) **ESC** key: Get back to the previous window.

(12) SD card slot cover: Open the cover to find a SD card slot and DC jack.

(13) DC jack: Connect the optional AC adapter. (For the SME-31A/101A only.)

(14) SD card slot: Correctly insert the SD card.
(Insert the SD card with the slanted corner set to the top-right.)

(15) Connector for NTB and SMET-1A connection:
Connect the NTB with the communication cable(for the SME-100A/101A only) or SMET-1A.

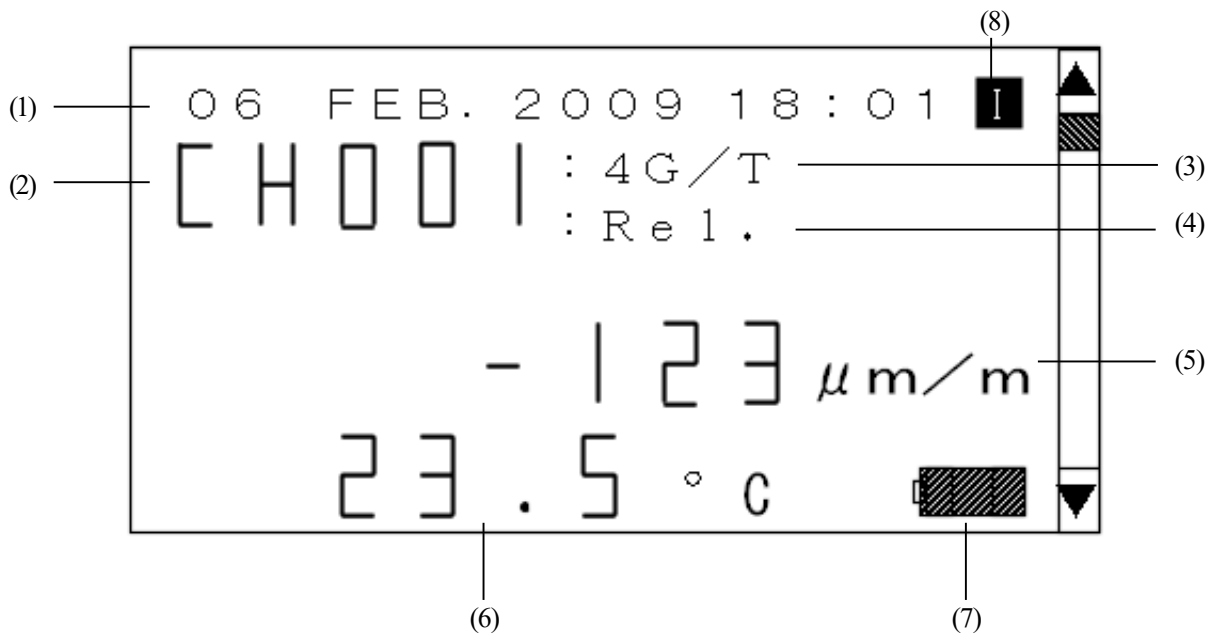

2-2. DESCRIPTION OF DISPLAY

(1) Monitor window



- (1) Time: Setting time of the SME series is displayed in due order from day, month, year, and time. Month is displayed as follows.
- | | | | |
|----------------|---------------|---------------|---------------|
| JAN: January | FEB: February | MAR: March | APR: April |
| MAY: May | JUN: June | JUL: July | AUG: August |
| SEP: September | OCT: October | NOV: November | DEC: December |
- (2) CH: Displays the selected CH No.
 "CH001" appears on the SME-30A/31A.
 "CH001" appears on the SME-100A/101A.
 However, when a CH of the NTB has been selected, the Box No. and CH of the target NTB appear.
 [Example] When the Box No. of the NTB is 01 and 3CH is selected, CH013 is displayed.
- (3) Input mode: Displays a setting input mode.
- (4) Relative value measurement:
 Reference junction compensation: When the Relative Value Measurement (Rel.) is set to ON, <Rel.> is displayed.
 With the TC/K mode and TC/T mode, the <Internal> (for the internal reference junction compensation) or <External> (for the external reference junction compensation) appears.
- (5) Measuring value: Displays a measuring value.
 When the Calculation Calibration Coefficient (Calc. Cal Coef.) is set to ON, a decimal point position or unit can be set.
- (6) Temperature: Temperature of the connecting civil engineering transducer with temperature measuring function is displayed.
- (7) Dry cell remaining capacity: Dry cell remaining capacity in 3 levels.
- (8) Interval measurement: During an interval measurement,  is displayed.

(2) State-of-battery Indication

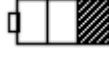
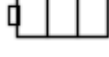
State-of-battery Indication	Alkaline Dry Cell	Nickel-hydrogen Dry Cell
	Full	Full
	There is sufficient power to use the device.	New dry cells are required for just in case.
	Dry cells may need to be replaced.	Replace the dry cells.
	Exhaust in a very short period of time. Replace the dry cells.	Nearly exhaust dry cells. Replace the dry cells.

(3) Basic method for displaying window

This section describes how to display the target window.

① How to describe the selecting item.

If the target item or character is selected on the SME series window, it blinks.
(<4G/T> in the right figure that is displayed with an outline character means blinking.)

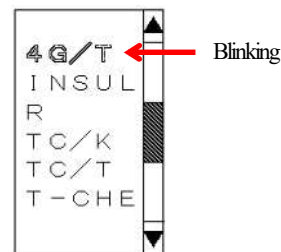

② Selection window

Window for selecting the target from several items

[Example] Selection window of input mode

Select a target item with the cursor key and push the **ENTER** key for setting.

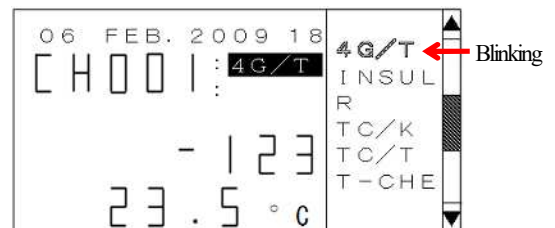

③ Edit window

Window for selecting and inputting characters and numbers

[Example] File name input window

Select target characters and numbers with the cursor key and push the **ENTER** key for setting.

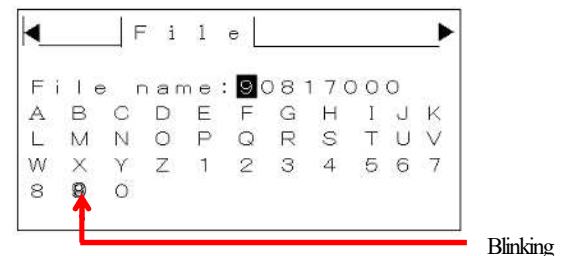

(Blank page)

3. HOW TO USE

3-1. BEFORE USING

[How to install the shoulder strap and wrist strap]

Install the shoulder strap or wrist strap as follows.

Also, be sure to connect the small strap (dry cell cover strap) from the top left loop and the second from top left loop to prevent losing the dry cell cover.



With the shoulder strap

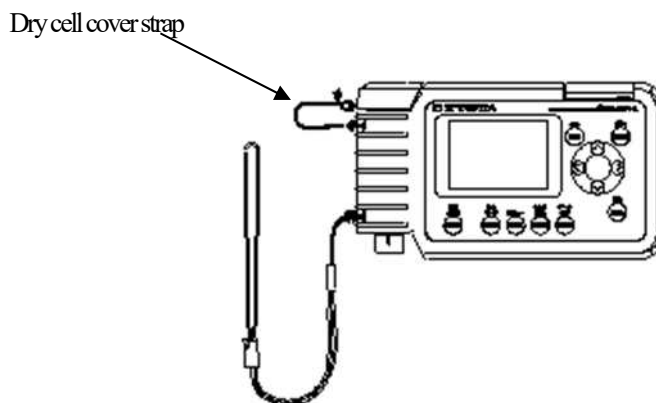

With the wrist strap

3-2. INSERTING DRY CELL

(1) Slide a dry cell cover while pushing in direction of arrows for removing.

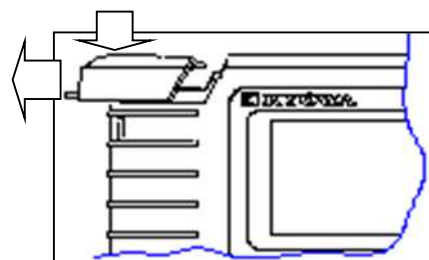

(2) Correctly insert dry cells.

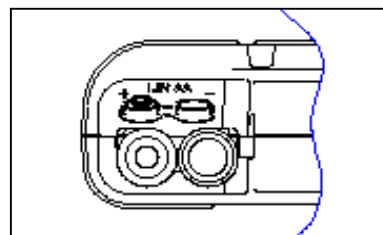

(3) Slide a dry cell cover while pushing in direction of arrows for closing.

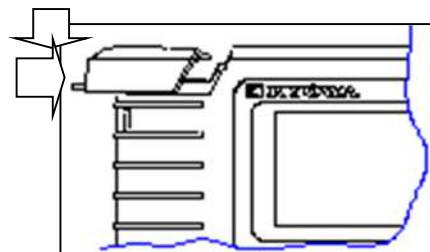

MEMO

- It is recommended to paste the tape on the dry cell cover so as not to open the dry cell cover carelessly.
- Use the size AA alkaline dry cells or nickel-hydrogen dry cells.

3-3. INSERTING AND REMOVING SD CARD

(1) For inserting the SD card

① Open a SD card slot cover to the arrow direction.

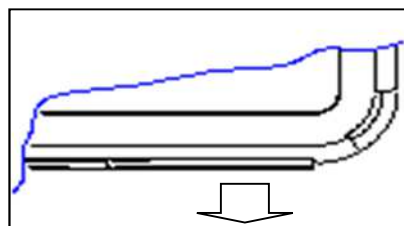

② Check the direction of the SD card.
Thoroughly insert the SD card until <click> sound is heard.

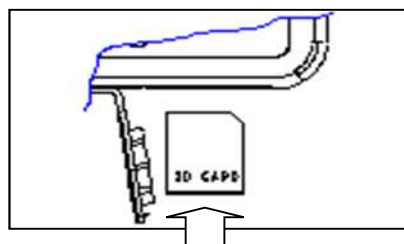

③ Close the SD card slot cover.

NOTE

- Before inserting or removing the SD card, be sure to turn OFF the SME series or get back to the monitor window.
- Correctly insert the SD card. Or, the SME series may cause trouble.
- SDHC cards is not available.
- It is recommended to format the SD card before using.
- Format the SD card in FAT16.

(2) For removing the SD card

① Open a SD card slot cover to the arrow direction.

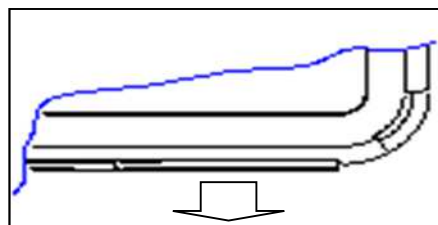

② Push the SD card until <click> sound is heard.
Remove your finger from the SD card, it will pop up little.

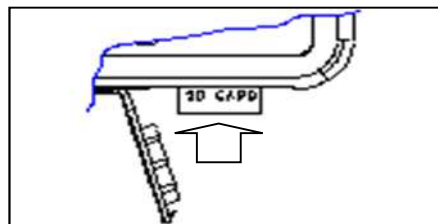

③ Pull the card straight up to remove.

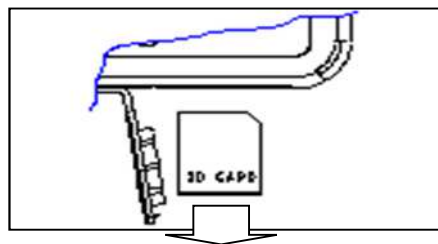

④ Close the SD card slot cover.

NOTE

- Do not remove the dry cells or SD card while accessing the SD card.
Or, the SD card may be broken.

3-4. POWER ON/OFF

(1) Power ON

- ① Push the **POWER** key approx. 3 seconds to turn ON the power.
- ② Model appears for approx. 1 second.

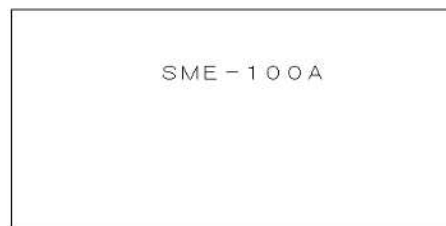

- ③ Monitor window appears.

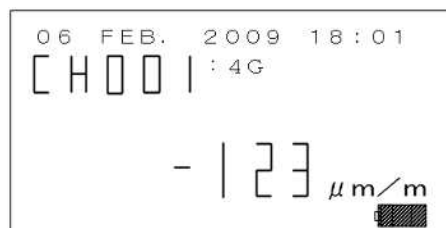

(2) Power OFF

- ① Push the **POWER** key approx. 1 second to turn OFF the power.

MEMO

If the **POWER** key is pushed too long for turning OFF, the power is turned ON again.
Release your finger from the **POWER** key after the display disappears.

3-5. INPUT SETTING

Select the target input mode that fits to the target sensor.

This section describes how to connect the civil engineering transducer with the temperature measuring function.

For connecting the civil engineering transducer with the temperature measuring function, set input mode to 4G/T.

(1) Push the **INPUT** key to display mode selection window.

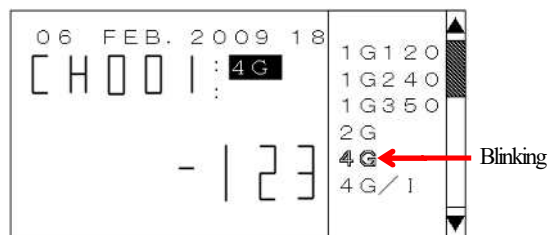

(2) Select the target mode with the cursor key.

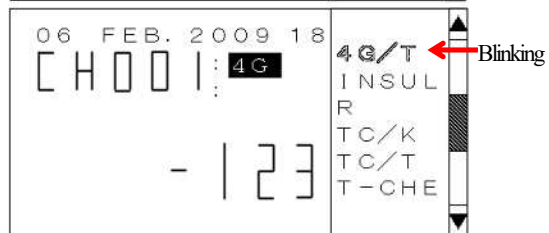

(3) Push the **ENTER** key for setting.

(4) The selected mode appears on the monitor window.

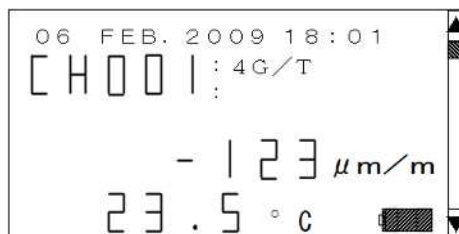

(5) Connect the sensor.

3-6. SENSOR CONNECTION

For the strain gage transducer with a connector plug (NDIS standard) applied to the cable tip, directly connect the transducer to the SME series connector.



For the strain gage or transducer without the connector plug, use the accessory input cable for connection.

Wirings for strain measurements with the input connector or input cable are described as follow.

(1) Input connector

Measuring Target	Connection Method	Remarks
Strain gage Strain gage transducer Civil engineering transducer with temperature measuring function Quarter bridge method 120, 240, 350 ohm Full bridge method 120 to 1000 ohm		A: +BV B: -SIG C: -BV D: +SIG E: Shield F: TEDS + G: TEDS - TEDS compatible

Measuring Method	Bridge Circuit	Connection Method	CH Mode
No measurement. Measuring data is space.	Legend: : Strain gage : Built-in fixed resistor A: Active gage E: Bridge exciter e: Bridge output	A: Active gage	SKIP
Quarter bridge method (2-wire system connection) Gage resistance 120,240,350 ohm			1G120 1G240 1G350
Quarter bridge method (3-wire system connection) Gage resistance 120,240,350 ohm			1G120 1G240 1G350

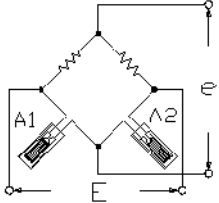
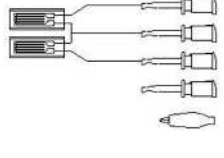
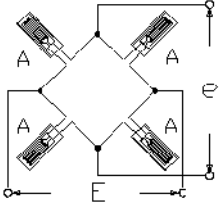
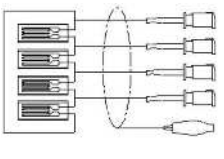
Measuring Method	<p style="text-align: center;">Bridge Circuit</p>  :Strain gage  :Built-in fixed resistor A: Active gage E: Bridge exciter e: Bridge output	<p style="text-align: center;">Connection Method</p> A: Active gage	<p style="text-align: center;">CH Mode</p>
Half bridge method (Active-active method) Gage resistance 120 to 1000 ohm		 <p style="margin-left: 20px;"> Red (+BV) White (-SIG) Black (-BV) Green (+SIG) Crocodile clip (Shield) </p>	2G
Full bridge method (Strain gage transducer) Gage resistance 120 to 1000 ohm		 <p style="margin-left: 20px;"> Red (+BV) White (-SIG) Black (-BV) Green (+SIG) Crocodile clip (Shield) </p>	4G 4GI

3-7. SAVING DATA

- (1) Push the **SAVE** key while displaying a monitor window.
- (2) <Saving...> appears on the monitor window and the measured data is recorded to the SD card.

**NOTE**

While displaying the <Saving...> on the monitor window, the SME series is accessing to the SD card.
 Do not remove the batteries or SD card while accessing the SD card.
 Or, the SD card may be broken.

MEMO

- <Write Protect> appears if the SD card is locked.
 The data cannot be saved.
 Unlock the SD card before operation.
 Push the **ESC** key to clear the <Write Protect.>
- <No Disk> appears if the operation related to the SD card is conducted with the SD card not inserted.
 Insert the SD card into the slot.
 Push the **ESC** key or insert the SD card to clear the <No Disk.>
- <Disk Err> appears if error (other than read and write errors) occurred in the SD card.
 Push the **ESC** key or solve the problem to clear the <Disk Err.>
 [Example] When the capacity of the SD card for recording the measured data is short.
- <Disk Read Err> appears if the read error occurred in the SD card for some reason.
 Push the **ESC** key or solve the problem to clear the <Disk Read Err.>
- <Disk Write Err> appears if the write error occurred in the SD card for some reason.
 Push the **ESC** key or solve the problem to clear the <Disk Write Err.>

(Blank page)

4. MEASUREMENT WITH NTB SERIES CONNECTED

The SME-100A/101A can check operation of the optional NTB or can measure data through the dedicated communication cable.

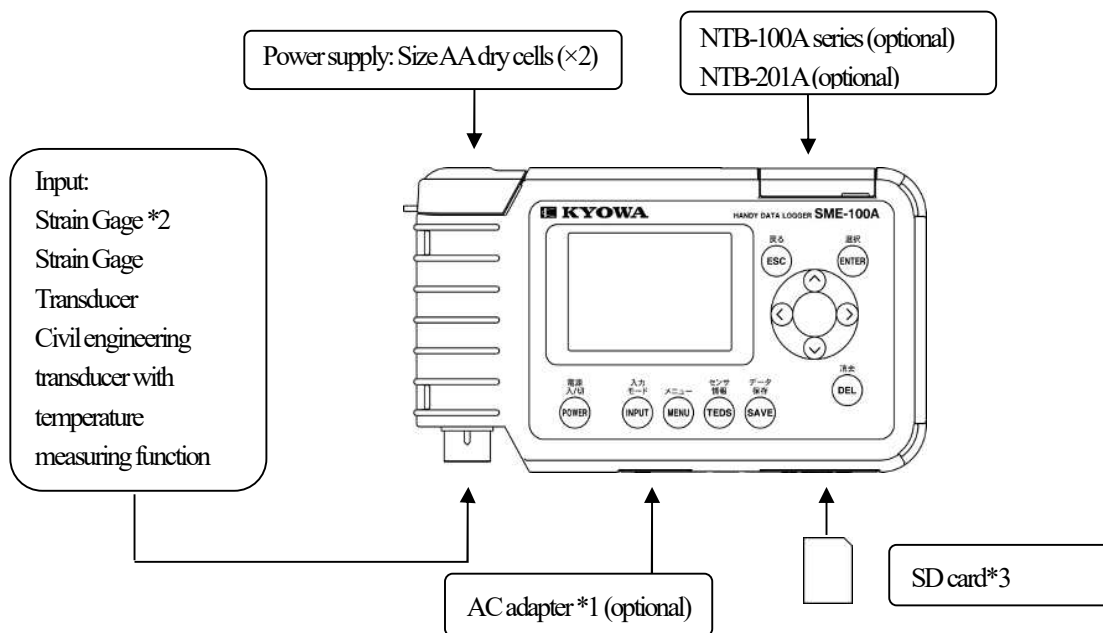

*1: Only the SME-101A can use the AC adapter.

*2: For measuring a strain gage, use the accessory input cable.

*3: The SD card is not included inside the package. You need to purchase a commercial product. SDHC cards is not available.

(1) Supply voltage to the NTB. Connect the SME series and NTB with the communication cable.

(2) Push the **MENU** key and select Env. menu.

(3) Push the **ENTER** key with <[Communication Check]> blinking.

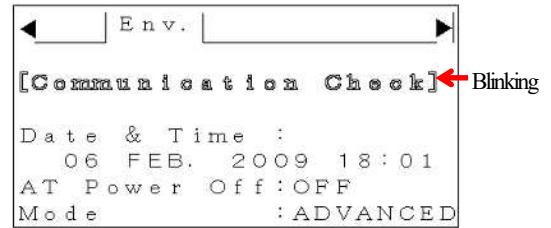

(4) Wait about 5 seconds to clear the <Communication Check>

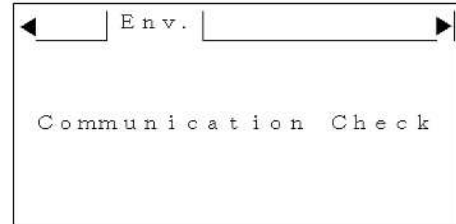

(5) Box No. and model of the current connecting NTB appear. Scroll a window with the cursor for checking.

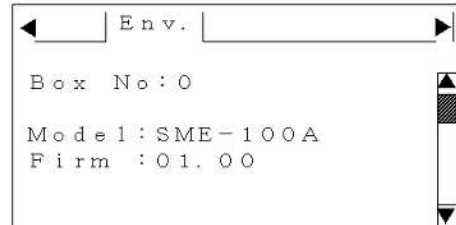

(6) Push the **ESC** key to get back to the monitor window.

(7) Scroll a window with the cursor key for checking the measured value.



The measured value of the NTB of the BOX No. 01 is displayed in the right.

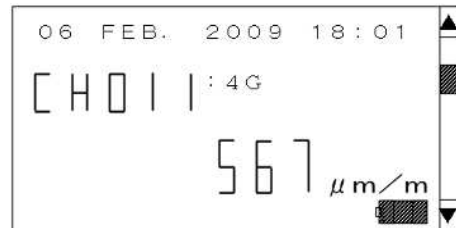

MEMO

During the <Communication Check>, the model of the SME is displayed as "BOX No. =0."

5. MEASUREMENT WITH SMET-1A CONNECTED

For measuring a temperature by using a thermocouple, use an optional SMET-1A with the SME series.

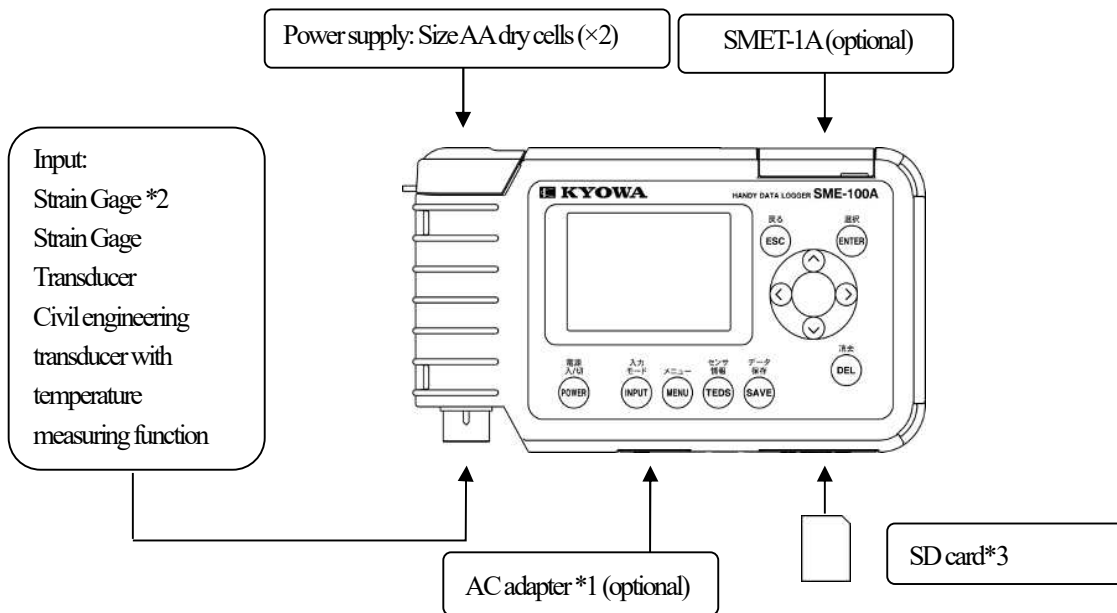

*1: Only the SME-31A/101A can use the AC adapter.

*2: For measuring a strain gage, use the accessory input cable.

*3: The SD card is not included inside the package. You need to purchase a commercial product. SDHC cards is not available.

SMET-1A

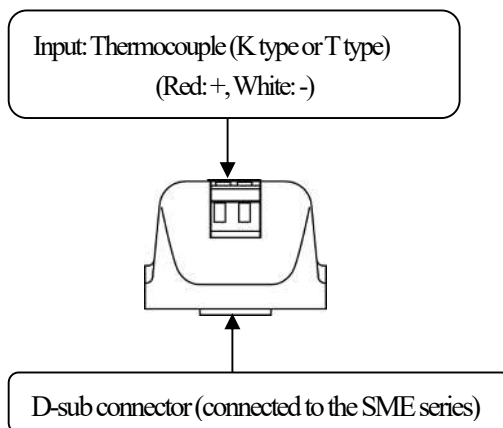

NOTE

- When using the SMET-1A, be sure to use the mounting screws.
- Before connecting or disconnecting the SMET-1A, be sure to turn OFF the SME series. Or, the SME series may cause trouble.

5-1. REMOVING/REATTACHING D-SUB COVER

If your SME series has the tape "Twist the lid to remove it." over the D-sub connector, the D-sub cover can be removed and reattached. For connecting the SMET-1A, follow the instructions.

If your SME series is not equipped with the D-sub cover and if you want to change the cover to a new type, contact KYOWA or our representatives.

We will change the D-sub cover to the new type with an extra cost.

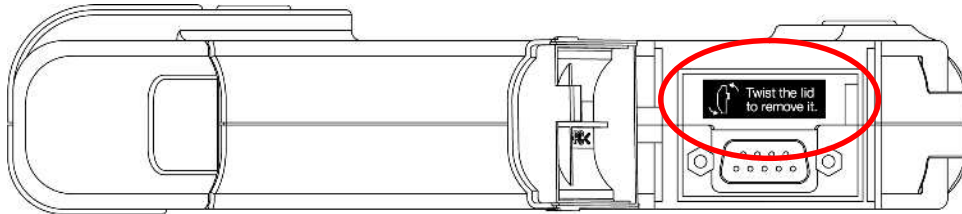

(1) Removing the D-sub cover

- ① Open the D-sub cover.

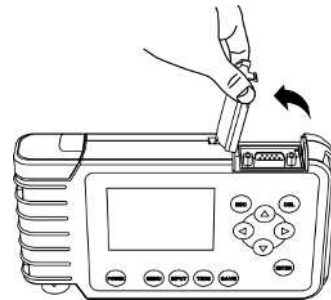

- ② Twist the D-sub cover to the left until <click> sound is heard.

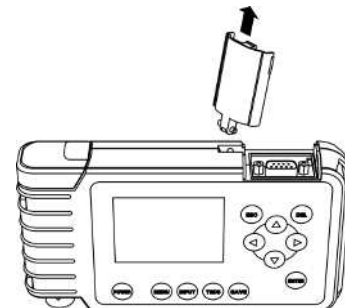
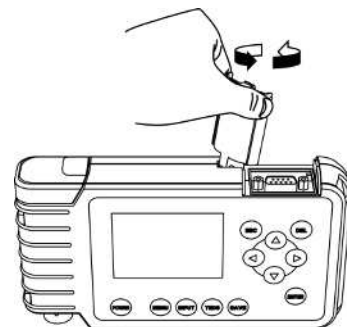

NOTE

Disconnect the SMET-1A before removing the D-sub cover.

(2) Reattaching the D-sub cover

- ① Set the D-sub cover into the SME series.



- ② Twist the D-sub cover to the right until <click> sound is heard.

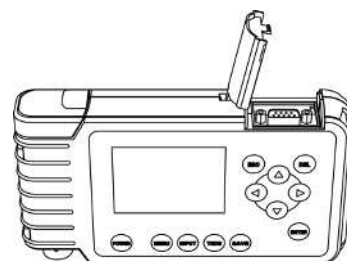
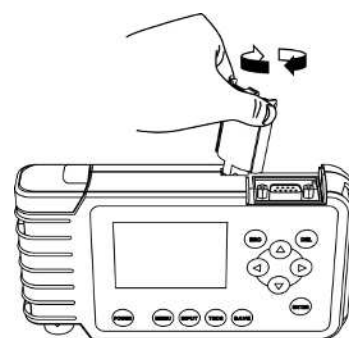

NOTE

Disconnect the SMET-1A before reattach the D-sub cover.

5-2. CONECTING/DISCONNECTING SMET-1A

(1) Connecting the SMET-1A

For connecting the SMET-1A, follow the instructions.

- ① Turn OFF the SME series.
- ② Connect the SMET-1A into the D-sub connector of the SME series.



- ③ Insert the accessory mounting screws (×2) into the holes on the SMET-1A.



- ④ Tighten the screws by using a philips-head screw driver.



NOTE

Before connecting the SMET-1A, be sure to turn OFF the SME series.
Or, the SME series may cause trouble.

(2) Disconnecting the SMET-1A

For disconnecting the SMET-1A, follow the instructions.

① Turn OFF the SME series.

② Remove the mounting screws (×2) by using a philips-head screw driver.



③ Disconnect the SMET-1A.



NOTE

Before disconnecting the SMET-1A, be sure to turn OFF the SME series.
Or, the SME series may cause trouble.

5-3. CONNECTING/DISCONNECTING THERMOCOUPLE

(1) Connecting a thermocouple

① Press the button on the terminal block.



② While pressing the button, insert a thermocouple.
Insert the + wire into the red terminal and - wire into the white terminal.



③ Release the button.
Check that the thermocouple is securely connected.



NOTE

The available wires are UL AWG14 to AWG28 for solid wires and UL AWG20 to AWG24 for stranded wires.
Never connect wires other than the above diameters. Failure to do so will pose the risk of measurement error and system failure.

MEMO

Before connecting the thermocouple into the terminal block, peel off the wire jackets approx. 9 to 10 mm.

(2) Disconnecting a thermocouple

① Press the button on the terminal block.



② While pressing the button, disconnect the thermocouple mounted on the terminal block.



5.4. MEASURING TEMPERATURE BY USING A THERMOCOUPLE

(1) Connect the SMET-1A into the SME series.

Turn ON the SME series.

(2) Push the **INPUT** key to display the mode selection window.

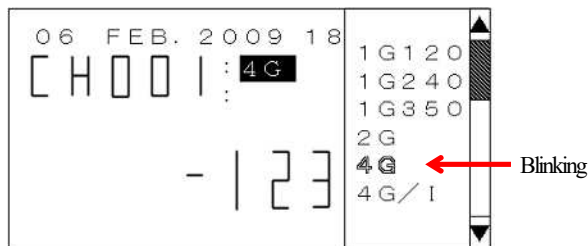

(3) Select the target mode appropriate to the thermocouple connected to the SMET-1A with the cursor key.

Thermocouple	Measuring CH mode
K-type thermocouple	TCK
T-type thermocouple	TCT

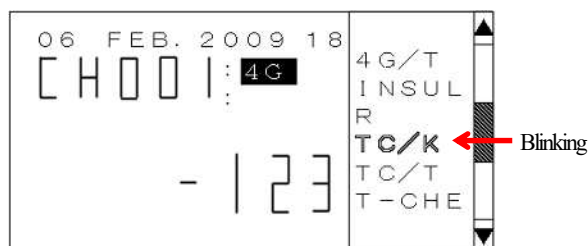

(4) Push the **ENTER** key for setting.

(5) The result appears on the monitor window.

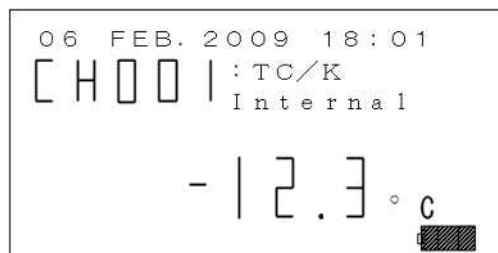

NOTE

Before measuring temperature, be sure to conduct the burnout checking (see "5-5 Burnout Checking").
Check that the <Burnout Check GOOD> appears on the monitor window.

MEMO

- When the temperature exceeds the temperature range, <999999> appears.
When the temperature lowers the temperature range, <-999999> appears.
- For details of the reference junction compensation, see "6-11 Switching Reference Junction Compensations."

5-5. BURNOUT CHECKING

The SME series checks the wire breakage of the thermocouple connected to the SMET-1A and displays the result.

- (1) Connect the SMET-1A into the SME series.
Turn ON the SME series.

- (2) Push the **INPUT** key to display the mode selection window.

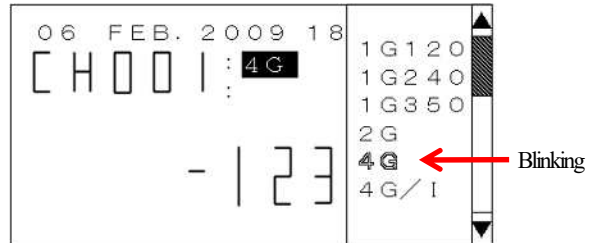

- (3) Select <T-CHE> with the cursor key.

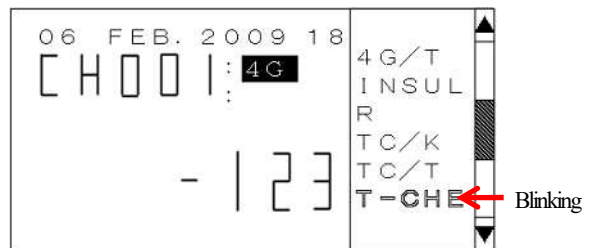

- (4) Push the **ENTER** key for setting.

- (5) The result appears on the monitor window.
<Burnout Check GOOD>: The thermocouple can be used.
<Burnout Check ERROR>: The thermocouple cannot be used.



(Blank page)

6. USEFUL FUNCTIONS

6-1. OPERATION MODE OF SME SERIES

This section describes various functions that are useful for the measurement of the strain gage transducer or strain gage.

In addition, when **ADVANCED** mark is placed next to the title, it is required to set the SME series to the ADVANCED mode. For the setting of the ADVANCED mode, see the following.

(1) How to set the ADVANCED mode.

① Push the **MENU** key and select the Env. menu.

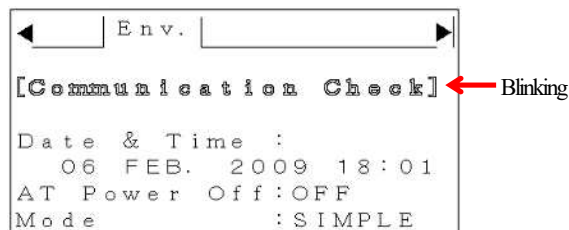

② Select <SIMPLE> with the cursor key.

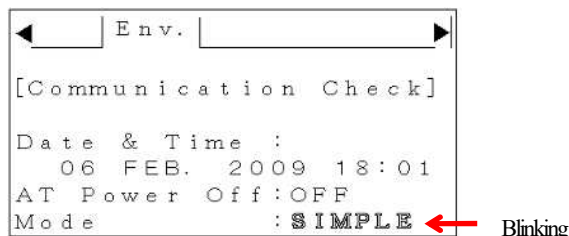

③ Push the **ENTER** key to display the mode selection window.

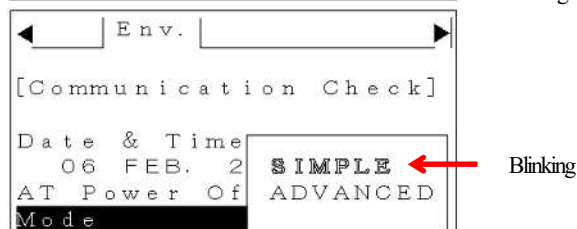

④ Select <ADVANCED> with the cursor key and push the **ENTER** key for the setting.

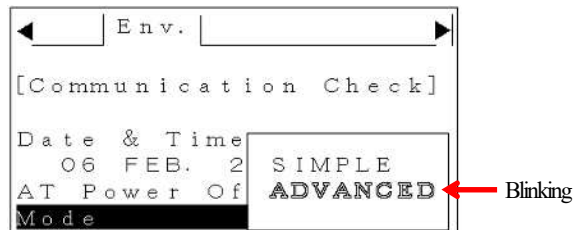

⑤ Push the **ESC** key to get back to the monitor window.

(2) How to set the SIMPLE mode.

If the SIMPLE mode is set, measurements other than direct reading of the sensor output value is restricted.

- ① Push the **MENU** key and select the Env. menu.

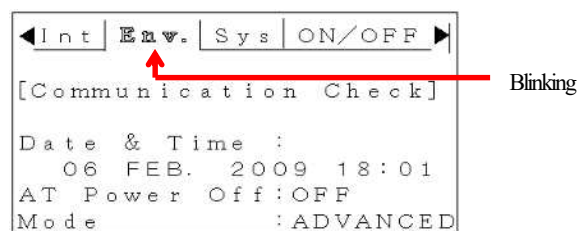

- ② Push the **ENTER** key to blink <[Communication Check.]>

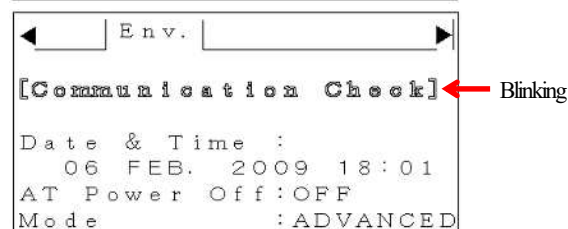

- ③ Select <ADVANCED> with the cursor key.

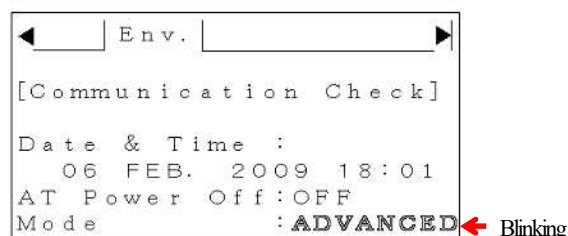

- ④ Push the **ENTER** key to display the mode selection window.

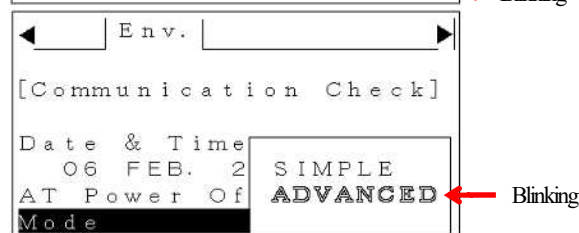

- ⑤ Select <SIMPLE> with the cursor key and push the **ENTER** key for the setting.

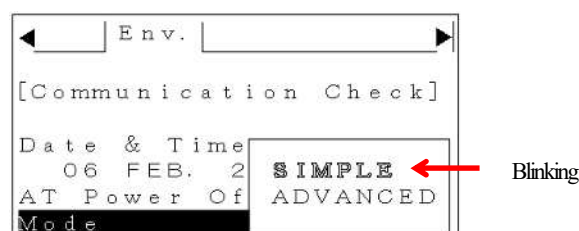

- ⑥ Push the **ESC** key to get back to the monitor window.

MEMO

Capable of conducting the following operations in the SIMPLE mode.

- Input mode changing
- Saving measured value to the SD card (File name: Last digit of the year + month + Day + 3- digit number)
- Connection to the NTB (SME-100A/101A only)
- Auto power OFF setting
- Time setting

Default setting is SIMPLE Mode.

6-2. RESISTANCE VALUE CHECKING

(1) Push the **INPUT** key to display the mode selection window.

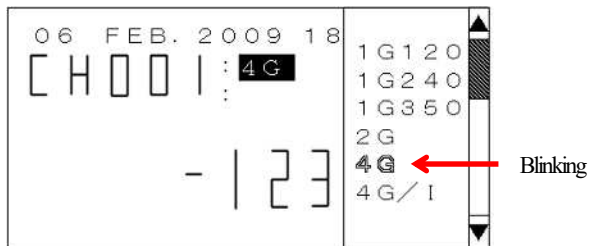

(2) Select <R> with the cursor key.

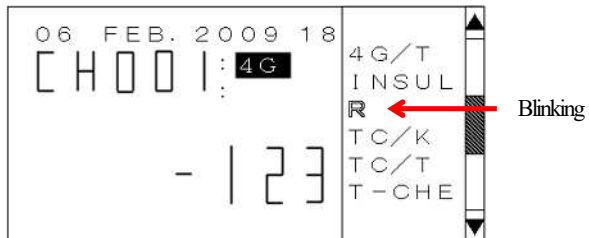

(3) Push the **ENTER** key for setting.

(4) <R> and resistance value appear on the monitor window.

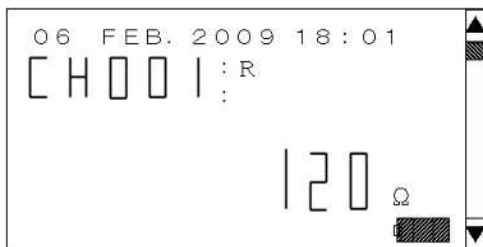

(5) Connect the input cable to the INPUT terminal.

(6) Connect the red and white wire of the input cable to the target position.

[Connection Method]

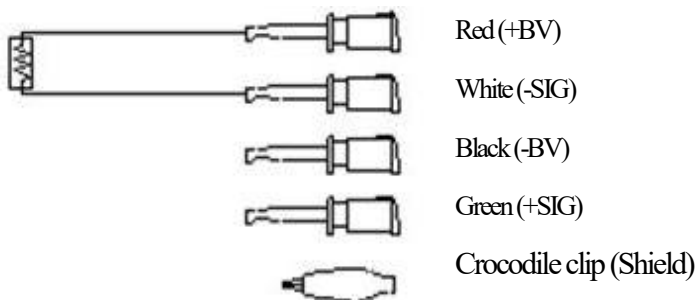

MEMO

Resistance value should be within 0 to 20 kohm.
 If the target resistance value exceeds 20 kohm, <999999> appears.

6-3. INSULATION CHECKING

(1) Push the **INPUT** key to display the mode selection window.

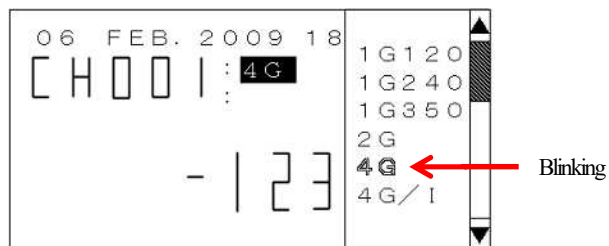

(2) Select <INSUL> with the cursor key.

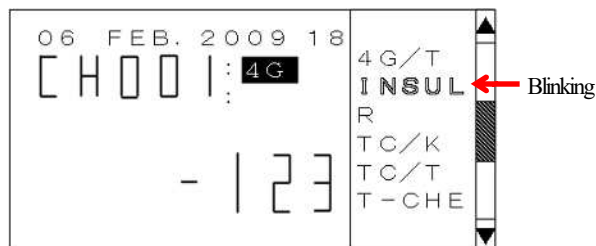

(3) Push the **ENTER** key for setting.

(4) <INSUL> and insulation resistance value appear on the monitor window.

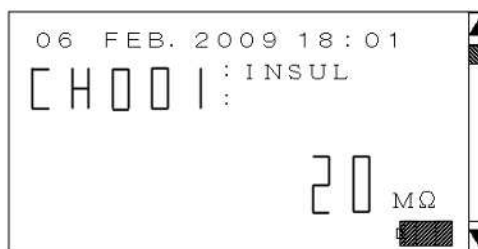

(5) Connect the input cable to the INPUT terminal.

(6) Connect the alligator clip and white clip of the input cable to the target place.

[Connection Method]

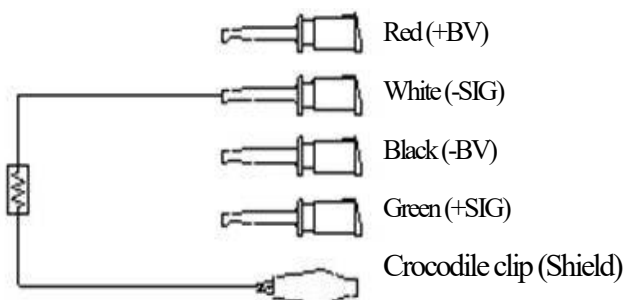

MEMO

Insulation resistance value should be within 2 to 100 Mohm.

If the target insulation resistance value is lower than 2 Mohm, <LOW> appears, higher than 100 Mohm, <HIGH> appears.

6-4. AUTO POWER OFF FUNCTION

After turning ON the AT Power Off, the SME series is automatically turned OFF in the following situation.

- Key operation is not conducted for 5 minutes or more.
- Waiting time during 3 minutes or longer interval.

(1) How to set the AT Power Off to ON.

① Push the **MENU** key and select the Env. menu.

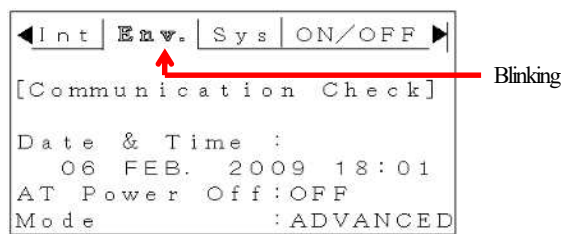

② Push the **ENTER** key to blink <[Communication Check.]>

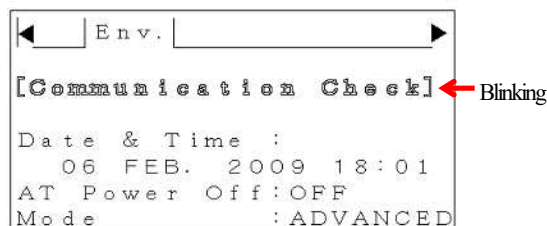

MEMO

When in SIMPLE mode, press the **MENU** key to display the Env. menu. Operation in item (2) is not required.

(3) Select <OFF> of the AT Power Off with the cursor key.

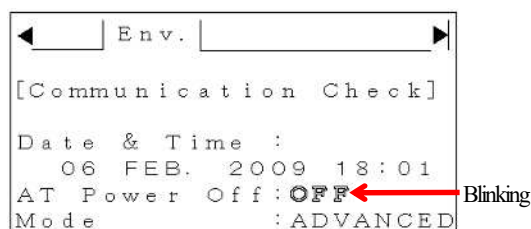

(4) Push the **ENTER** key to display the mode selection window.



(5) Select <ON> with the cursor key and push the **ENTER** key for setting.

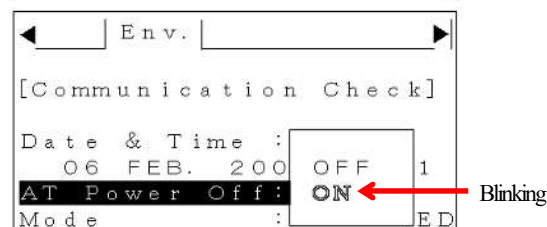

(6) Push the **ESC** key to get back to the monitor window.

(2) How to set the AT Power Off to OFF.

① Push the **MENU** key and select the Env. menu.

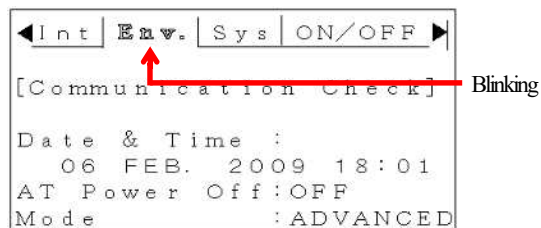

② Push the **ENTER** key to blink <[Communication Check]>

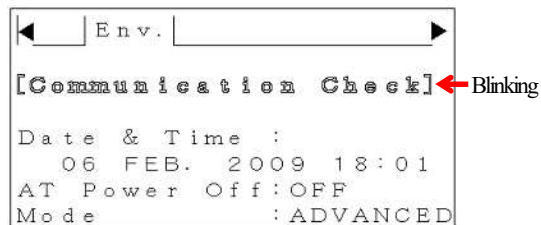

MEMO

When in SIMPLE mode, press the **MENU** key to display the Env. menu. Operation in item (2) is not required.

③ Select <ON> of the AT Power Off with the cursor key.

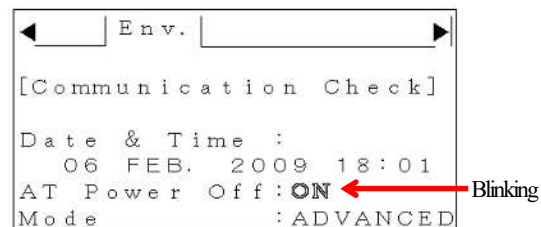

④ Push the **ENTER** key to display the mode selection window.

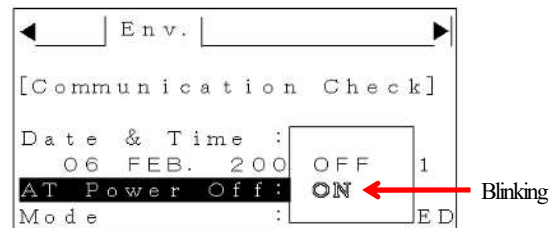

⑤ Select <OFF> with the cursor key and push the **ENTER** key for setting.

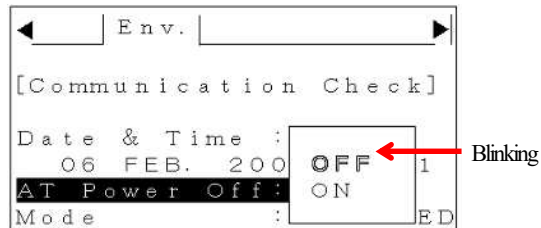

⑥ Push the **ESC** key to get back to the monitor window.

6-5. RELATIVE VALUE MEASUREMENT **ADVANCED**

If the relative value measurement is used, each value is obtained by deducting the initial unbalance value.

For using a strain gage or strain gage transducer, be sure to measure an initial unbalance value of sensors in no load state before a measurement and deduct the initial unbalance value to obtain a measured value.

In the SME series, an operation that measures the initial unbalance value is called a ZERO Measurement (hereinafter referred to as the ZERO Meas.).

In addition, the measured value of the ZERO Meas. is called a ZERO value.

For using the Calculation calibration Coefficient (Calc. Cal Coef), be sure to turn ON the relative value measurement and set the measured value after the ZERO Meas.

MEMO

When the relative value measurement is set to ON (Rel.: ON), <Rel.> appears on the monitor window.

Measured value on the monitor window is the value with deducting the ZERO value saved in the SME series.

(1) How to set the relative value measurement.

① Push the **MENU** key.

② Select the <Func.> menu.

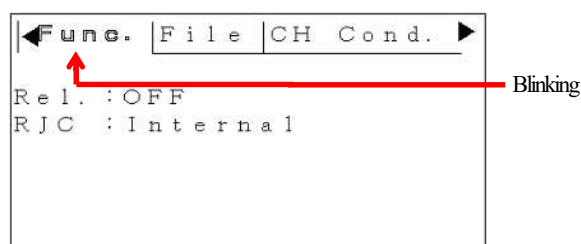

③ Push the **ENTER** key and select the <Rel.: OFF>.

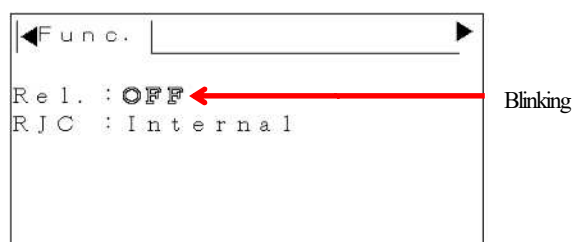

④ Push the **ENTER** key to display the mode selection window.

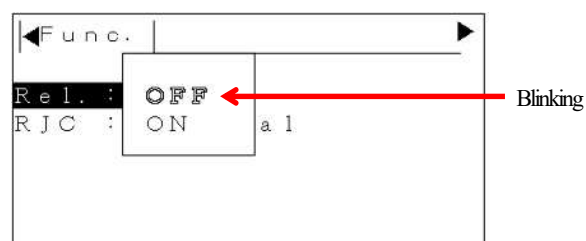

⑤ Select <ON> with the cursor key and push the **ENTER** key for setting.

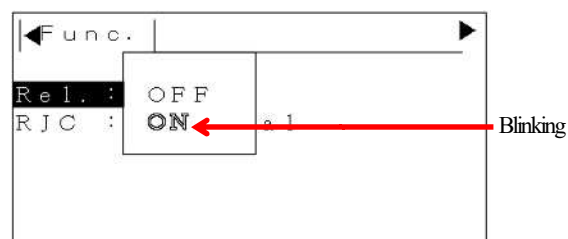

(2) How to measure ZERO value.

- ① Push the **ENTER** key with <[ZERO Meas.]> of the Func. menu blinking.

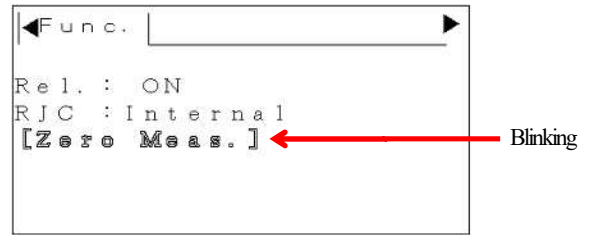

- ② Measure ZERO value for displaying.



- ③ Automatically get back to the Func. menu.

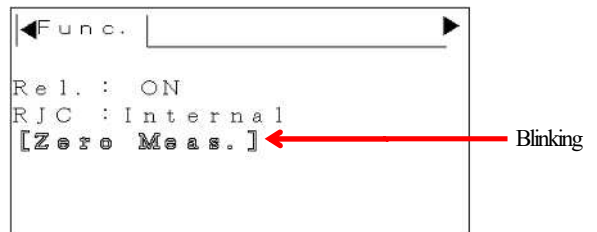

- ④ Push the **ESC** key to get back to the monitor window.

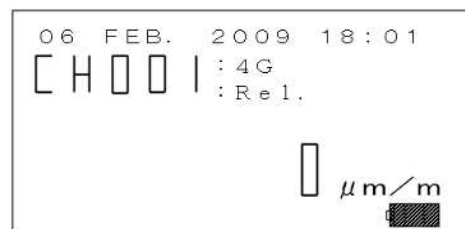

MEMO

When the relative value measurement is set to ON (Rel.: ON), <Rel.> appears on the monitor window.

6-6. CALC. CAL COEF. (FOR DISPLAYING PHYSICAL QUANTITY)

ADVANCED

Capable of displaying physical quantity by multiplying the Cal Coef. of the sensor to the strain, setting the decimal point, and displaying the unit.

In addition, arbitrary CH name can be set.

Use the Calc. Cal Coef. after turning ON the relative value measurement and after conducting the Zero Meas.

To set the Calc. Cal Coef. to ON, select <ON> of the Calc. Cal. Coef. of the ON/OFF menu.

(1) How to set the Cal Coef.

① Push the **MENU** key.

② Select CH Cond. menu with the cursor key.

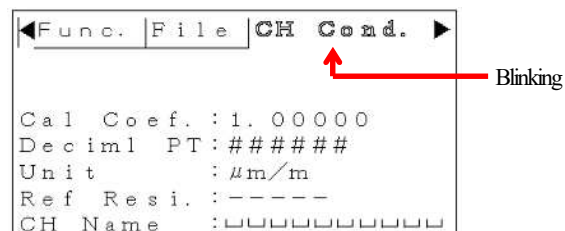

③ Push the **ENTER** key to blink the right side number of the <Cal Coef.>.

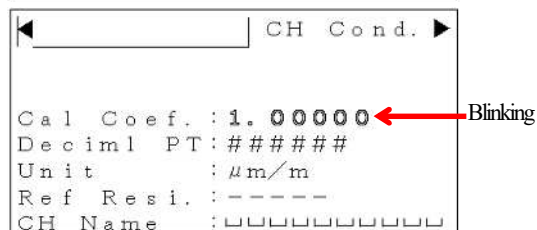

④ Push the **ENTER** key for edit window.

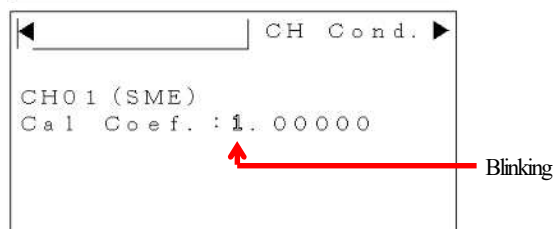

⑤ Push the **ENTER** key for changing the target number.

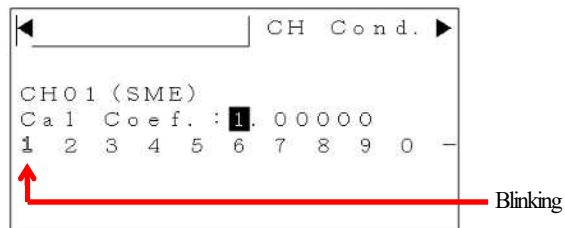

⑥ Select the target number with the cursor key.

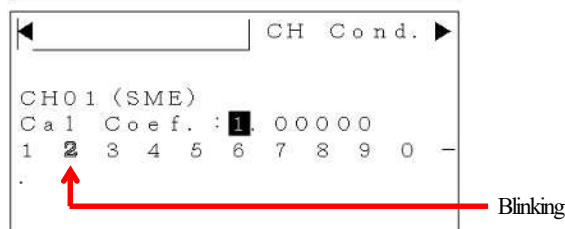

⑦ Push the **ENTER** key for determining.

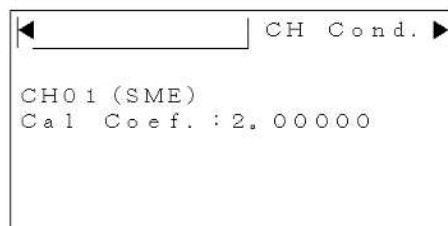

⑧ Repeat operations of item ④ to ⑥ to input numbers.

⑨ Push the **ESC** key to get back to the monitor window.

(2) How to set Deciml PT.

① Push the **MENU** key.

② Select CH Cond. menu with the cursor key.

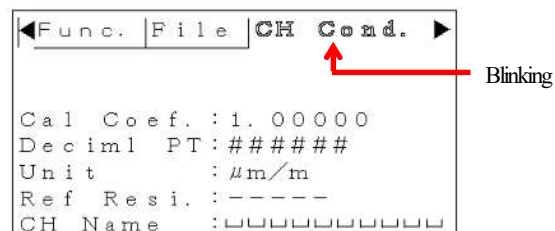

③ Push the **ENTER** and select the <Deciml PT> with the cursor key.

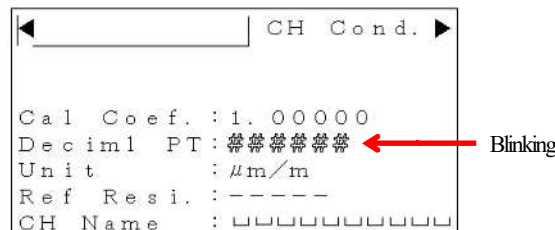

④ Push the **ENTER** key to display the selection window.

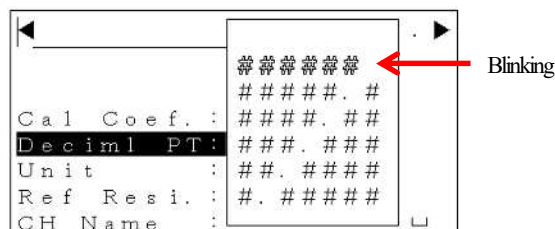

⑤ Select the target decimal point by the cursor key.

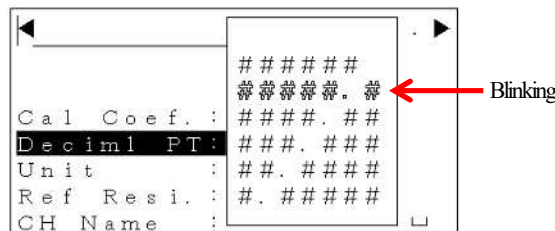

⑥ Push the **ENTER** key for determining.

⑦ Push the **ESC** key to get back to the monitor window.

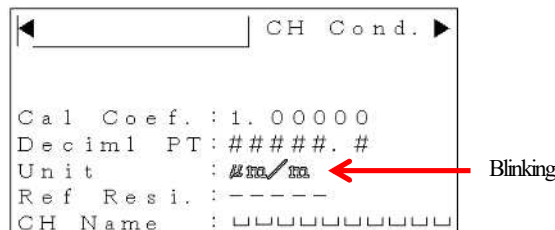

NOTE

With the TC/K mode and TC/T mode, the Calculation Calibration Coefficient (Calc. Cal Coef.) is OFF.

6-7. READING/WRITING TEDS INFORMATION

ADVANCED

TEDS is an acronym for Transducer Electronic Data Sheet.

Calibration coefficient and displaying unit can be automatically set by using the TEDS.

(1) How to read the TEDS information.

① Push the **TEDS** key while displaying the monitor window.

② Push the **ENTER** key with <Read> blinking in the TEDS menu.

```
TEDS |
-----
[Read] ← Blinking
[Write]
```

③ Reading window appears.

```
TEDS |
-----
Reading...
(STOP: Push Esc Key)
```

④ Result window appears.

If the TEDS information is correctly read, <GOOD> appears in the “Result” column.

```
TEDS |
-----
CH  Result (Read)
001 GOOD ← Blinking
```

⑤ Push the **ENTER** key to display the read content of the target CH No.

```
TEDS |
-----
Cal Coef. : 0. 21645
Deciml PT: 1
Unit      : N
CH Name   : KYOWATEST1
```

⑥ Push the **ESC** key to get back to the monitor window.

NOTE

For using the TEDS function, be sure to use the KYOWA made TEDS sensor.
When using other manufacture made sensor, information cannot be read correctly.
Even if the KYOWA made sensor is used, information may not be read correctly.

MEMO

Read content is reflected to the setting of the CH Cond. menu.
For displaying physical quantity, select the <Calc. Cal Coef.: ON> of the ON/OFF menu.

(2) How to write CH Name.

This section describes how to write the CH Name that is set in the CH Cond. menu to the sensor.

- ① Push the **TEDS** key while displaying the monitor window.
- ② Push the **ENTER** key with <Write> on the TEDS menu blinking.

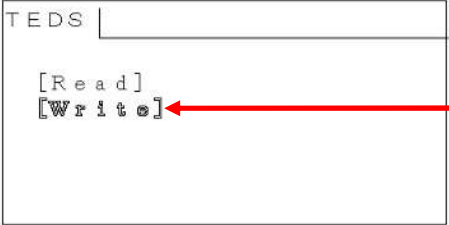

TEDS | _____
 [Read]
 [Write] ← Blinking

- ③ <Write to TEDS OK?> appears.
 Push the **ENTER** key for writing.

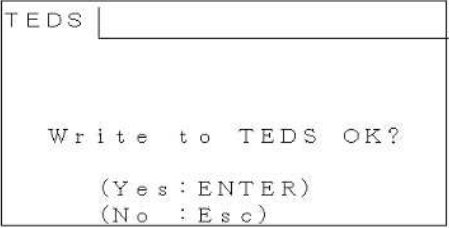

TEDS | _____
 Write to TEDS OK?
 (Yes : ENTER)
 (No : Esc)

- ④ <Writing...> disappears and <GOOD> appears in the <Result> column.



TEDS | _____
 Writing...

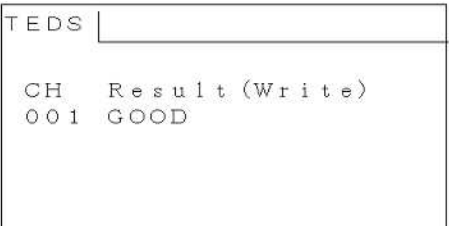

TEDS | _____
 CH Result (Write)
 001 GOOD

- ⑤ Push the **ESC** key to get back to the monitor window.

NOTE

For using the TEDS function, be sure to use the KYOWA made TEDS sensor.
 When using other manufacture made sensor, information cannot be written.
 Even if the KYOWA made sensor is used, information may not be written.

6-8. INTERVAL MEASUREMENT

ADVANCED

Interval measurement measures value at the preset interval and records the measured value to the SD card.

Set Meas Start Time, Intval Time, and Times and select <Interval. Meas.: ON> of the ON/OFF menu for the measurement.

① Push the **MENU** key.

② Select Intvl menu with the cursor key.

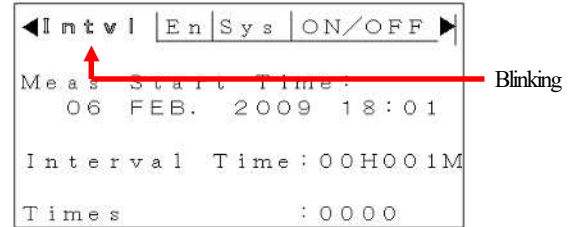

③ Push the **ENTER** key to blink the date of the <Meas Start Time>. Push the **ENTER** key.

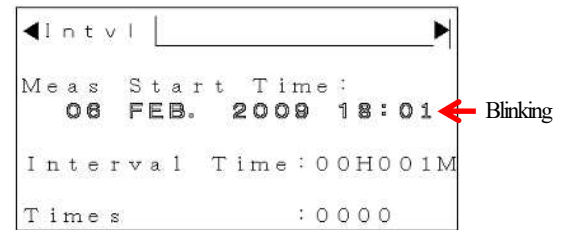

④ Set the <Meas Start Time> with the **ENTER** key and cursor key.

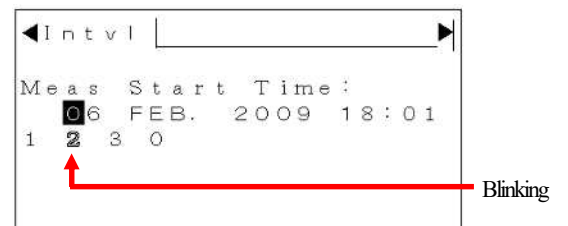
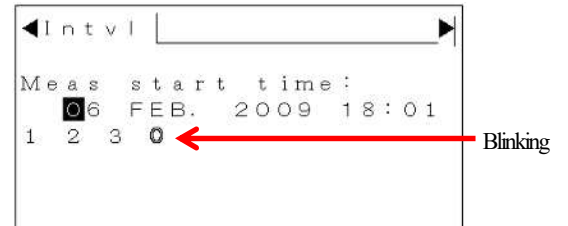
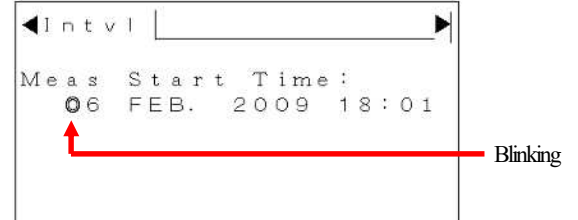

⑤ Push the **ESC** key to get back to the Intvl menu. Set <Intval Time> and <Times> in the same way.

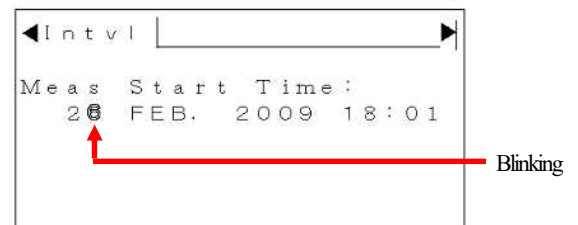

⑥ Push the **ESC** key to display the menu window.

- ⑦ Select ON/OFF menu with the cursor key.

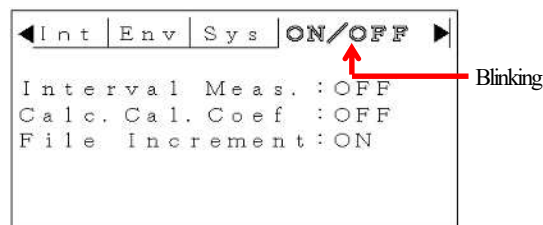

- ⑧ Select <Intval. Meas.: ON> with the **ENTER** and cursor keys.

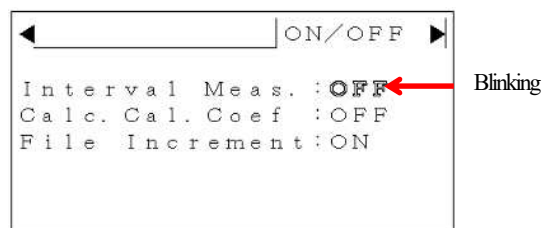

- ⑨ Push the **ESC** key to get back to the monitor window.
Check that **I** appears in the upper right of the monitor window.

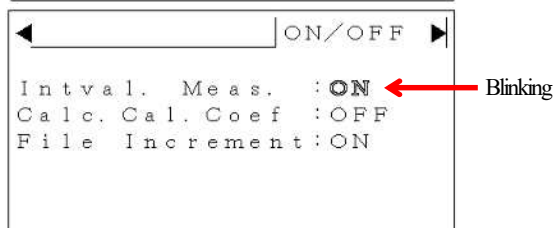

MEMO

- When the interval time is 3 minutes or more with the AT Power Off set to ON, after measuring once, the power is automatically turned OFF

In addition, the power is automatically turned ON before 1 minute of the measuring time and turned OFF again after the measurement.

- When setting the Meas Start Time, push the **DEL** key to input the current time.

If the current time is already passed the Interval Time, the SME series automatically calculates the next measuring time by using the interval and starts the measurement.

- If the **POWER** key is pressed, the power is never turned OFF during 1 minute before the measuring time.

- To stop the interval measurement, select <Interval Meas.: OFF> of the ON/OFF menu.

6-9. FILE OPERATION

ADVANCED

This section describes how to set the file name that is saved in the SD card, how to display or delete the saved file name in the SD card, and how to change the file name.

(1) How to set file name.

① Push the **MENU** key.

② Select File menu with the cursor key.

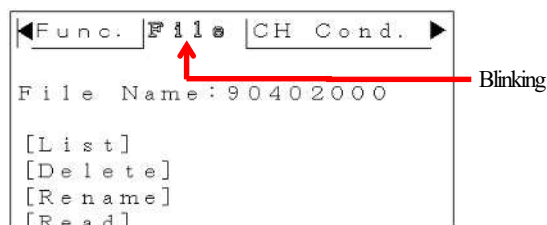

③ Push the **ENTER** key to blink the current setting file name.

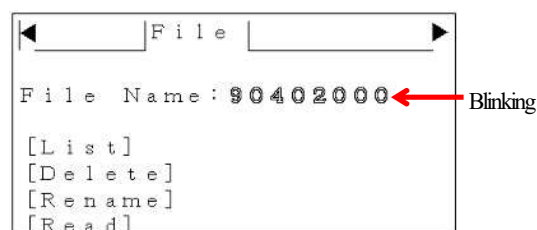

④ Select the target alphanumeric with the **ENTER** key and cursor key to set the file name.

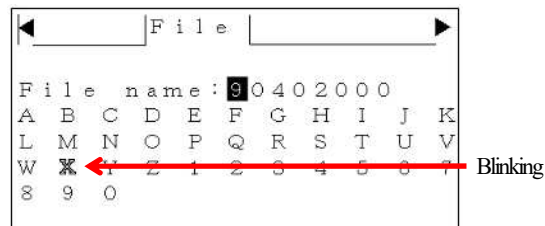
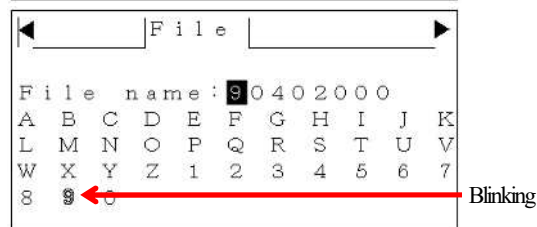
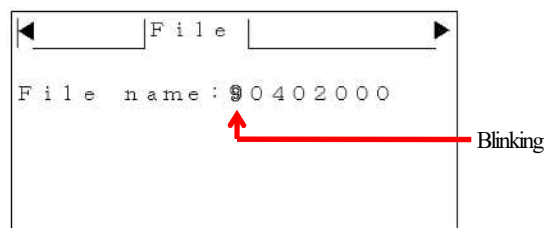

⑤ After inputting all, push the **ESC** key to get back to the monitor window.

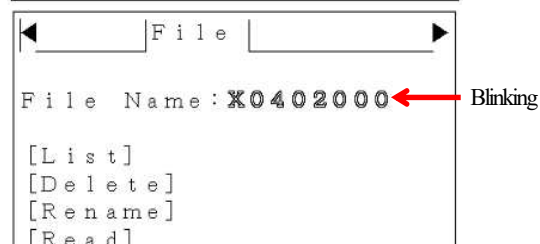

MEMO

- While the File name is blinking, push the **DEL** key to automatically change the file name as follows.
Last digit of the year + month + Day + 3-digit number

Example: 2009 December 19 → 91219***

- When setting a file name that is already saved in the SD card, <Duplicate Name Error> message appears.
Press the **ENTER** key to display the file name setting window again.
Or press the **ESC** key to add the data behind the existing file.

(2) How to display the file name list.

- ① Push the **MENU** key.
- ② Select File menu with the cursor key.

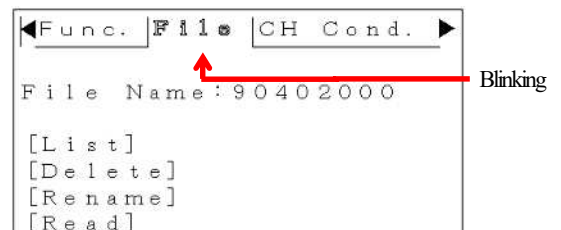

- ③ Push the **ENTER** key.
Select <List> with the cursor key.

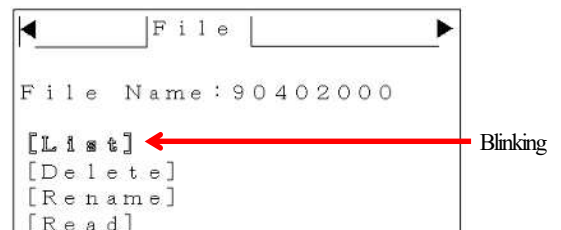

- ④ Push the **ENTER** key to display the currently saved file name in the SD card.

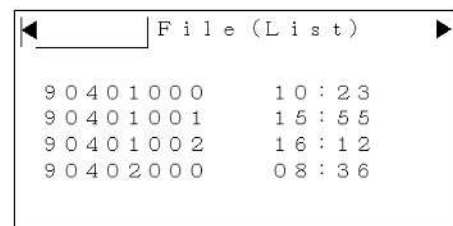

(3) How to delete the file.

- ① Push the **MENU** key.
- ② Select File menu with the cursor key.

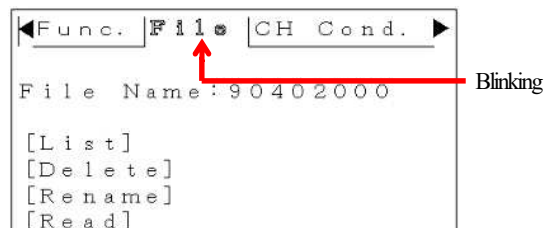

- ③ Push the **ENTER** key.
Select <Delete> with the cursor key.

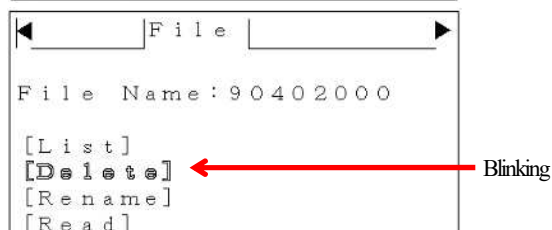

- ④ Push the **ENTER** key to display the currently saved file name in the SD card.

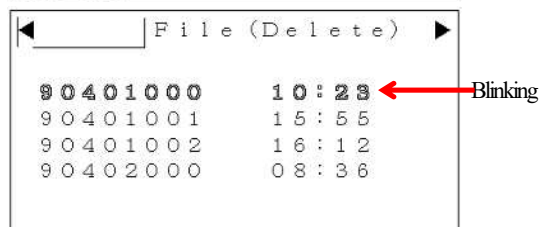

- ⑤ Select the target file and push the **DEL** key for setting.

- ⑥ Push the **ENTER** key to display <Delete file OK?>.

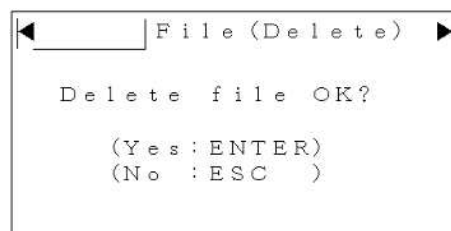

- ⑦ Push the **ENTER** key again to delete the file.

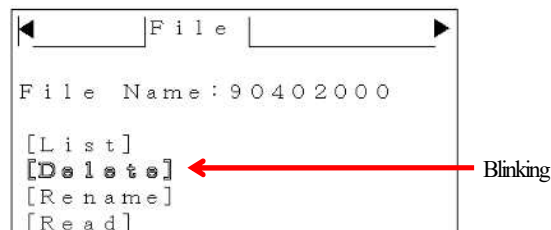

(4) How to change file name.

- ① Push the **MENU** key.
- ② Select File menu with the cursor key.

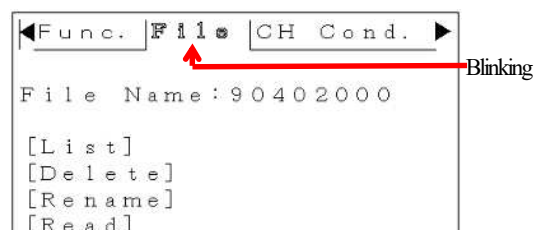

- ③ Push the **ENTER** key.
Select <Delete> with the cursor key.

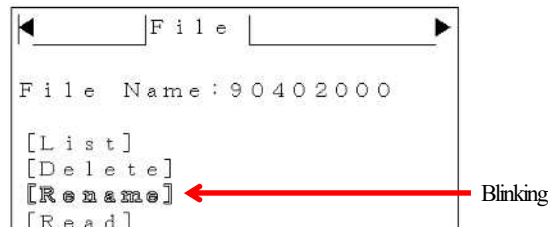

- ④ Push the **ENTER** key to display the currently saved file name in the SD card.

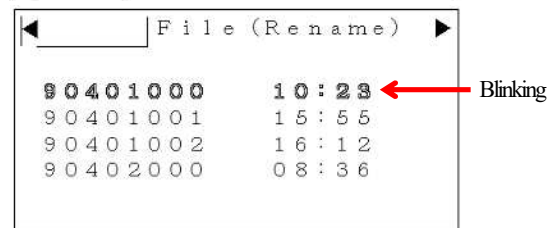

- ⑤ Select the target file with the cursor key and push the **ENTER** key for setting.

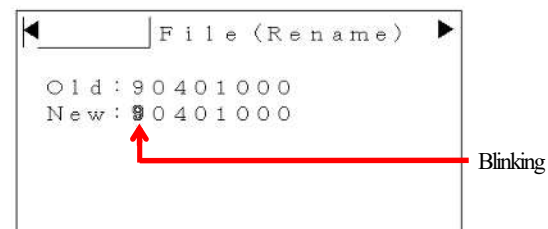

- ⑥ Old file name and New file name appears.

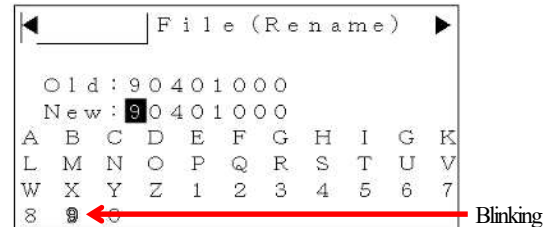

- ⑦ Input new file name with the cursor key and **ENTER** key.

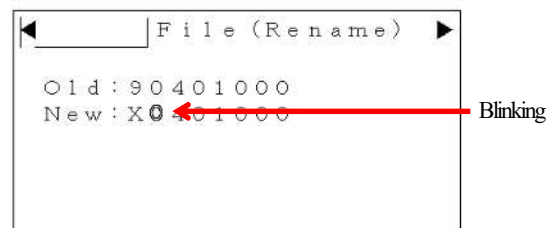
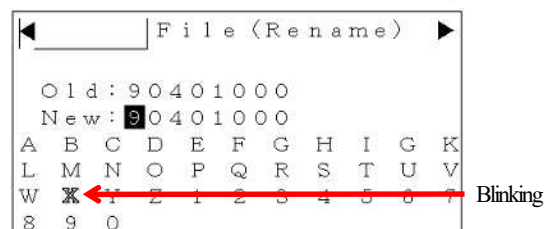

- ⑧ Push the **ESC** key to get back to the monitor window.

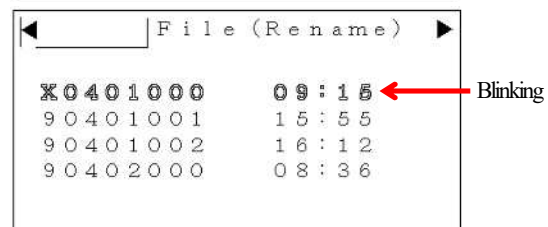

MEMO

- If the same file name exists in the SD card, <Duplicate Name Err> appears.
- Press the **ESC** key to stop the changing operation of the file name and get back to the previous window.
Change a file name into another name or delete the data having the same file name.

(5) Reading the file (reading the Zero value)

The SME series can display the Zero value pre-set in the "Saving file."

① Push the **MENU** key.

② Select File menu with the cursor key.

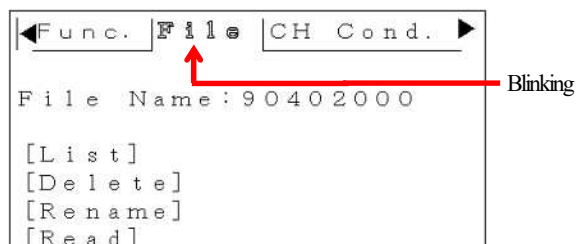

③ Push the **ENTER** key.

Select <Read> with the cursor key.

Push the **ENTER** key again.

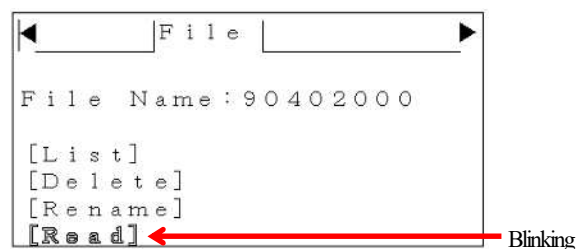

④ Push the **ENTER** key with <[Read Zero]> blinking.

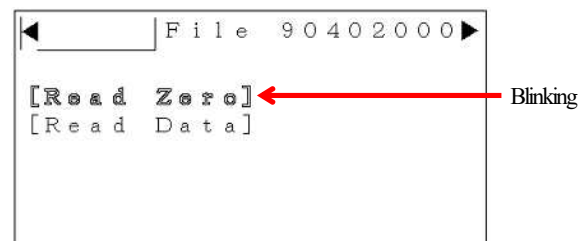

⑤ Displays the Zero value of the current CH.

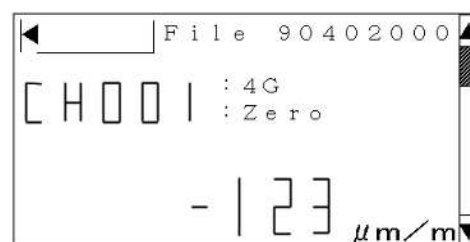

(6) Reading the file (reading the measured value)

The SME series can display the measured value pre-set in the "Saving file."

① Push the **MENU** key.

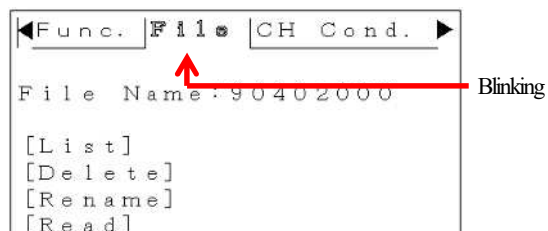

② Select File menu with the cursor key.

③ Push the **ENTER** key.

Select <Read> with the cursor key.

Push the **ENTER** key again.

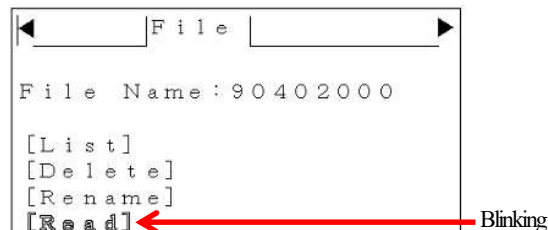

④ Push the **ENTER** key with <[Read Zero]> blinking.

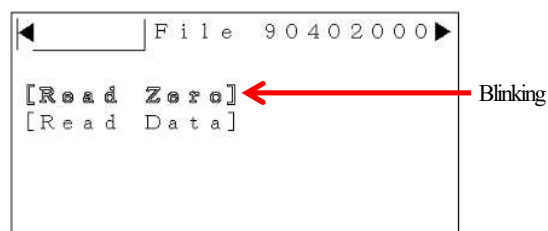

⑤ Push the **ENTER** key with <[Read Data]> blinking.

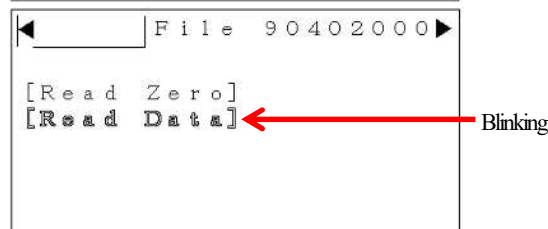

⑥ Displays the data of the current CH.

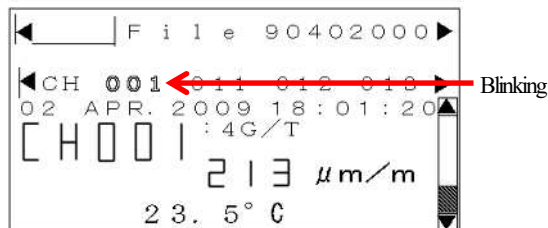

MEMO

- The number of measured values that can be displayed are approximately as follows.
 Example 1: When measuring data for 33 channels, the latest 20 data can be displayed.
 Example 2: When measuring data for 1 channel, the latest 150 data can be displayed.
- The SME series can load measured values pre-set in the <File Name> by using this function.
 However, the SME series cannot load measured values saved in the SD card for displaying.

6-10. FILE INCREMENT SETTING **ADVANCED**

With the <File Increment>, select <ON> or <OFF>.

<ON>: When you change the channel conditions, etc., the SME series automatically increments the file name.

The last 3 digits of the file name is incremented by one for creating a new file.

The SME series saves the data in the new file.

Example: 91125000 → 91125001 (2009, November, 25)

However, if all files (from 000 to 999) exist already, the SME series do not change the file name.

The data is saved in the file used in the last.

<OFF>: When you change the channel conditions, etc., the SME series adds data to the existing file.

The SME series saves the conditions including the changed parts and data at the end of the existing file.

MEMO

- When the <File Increment> is <ON>, a file name automatically increments by changing the following conditions.

- (1) Interval conditions
- (2) ON/OFF setting of the relative value measurement
- (3) ON/OFF setting of the calculation calibration coefficient (Calc. Cal Coef)
- (4) Conditions of the NTB
- (5) ZERO value measurement
- (6) Other conditions

- When using the SME series in the SIMPLE mode, the <File Increment> is <ON>.

You cannot set the file name manually.

- When the <File Increment> is <ON> and conditions of the NTB are changed during the communication checking, the SME series adds data into the existing file only.

6-11. SWITCHING REFERENCE JUNCTION COMPENSATION **ADVANCED**

(1) To the external reference junction compensation

This section describes how to switch the internal reference junction compensation to the external reference junction compensation.

① Push the **MENU** key.

② Select the <Func.> menu.

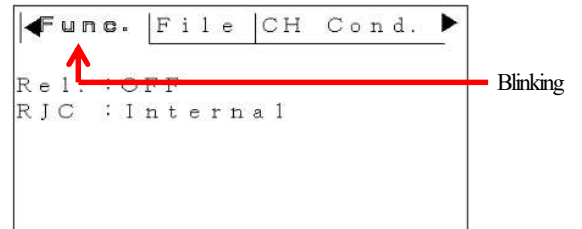

③ Push the **ENTER** key to display the menu.

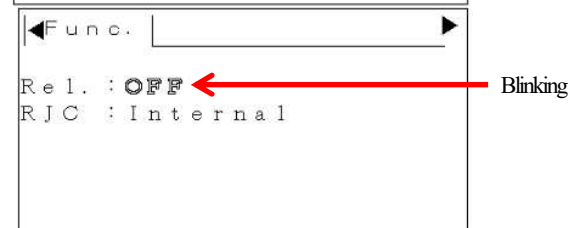

④ Select <Internal> with the cursor key.

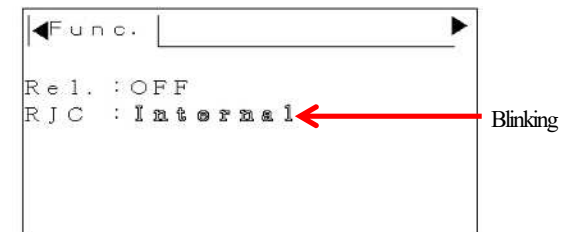

⑤ Push the **ENTER** key to display the mode selection window.

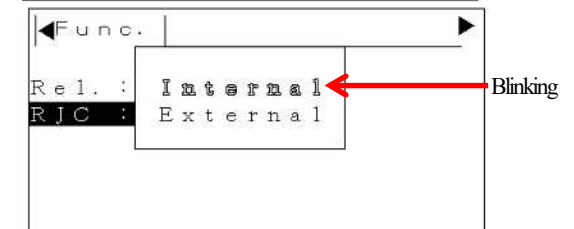

⑥ Select <External> with the cursor key.

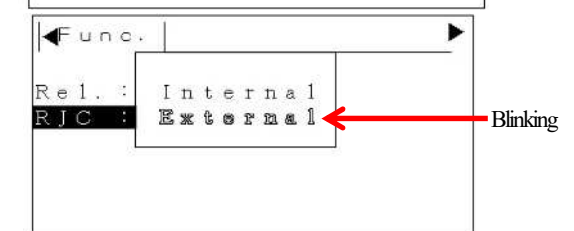

⑦ Push the **ENTER** key for setting.

⑧ Push the **ESC** key to get back to the monitor window.

(2) To the internal reference junction compensation

This section describes how to switch the external reference junction compensation to the internal reference junction compensation.

① Push the **MENU** key.

② Select the <Func.> menu.

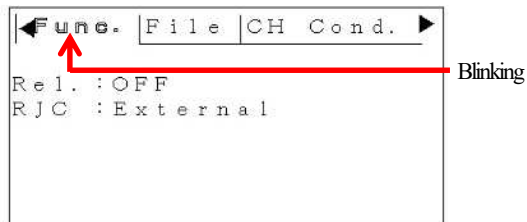

③ Push the **ENTER** key to display the menu.

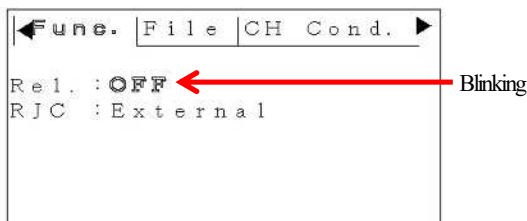

④ Select <External> with the cursor key.

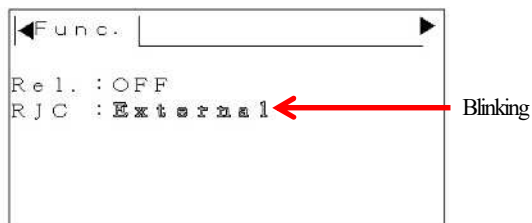

⑤ Push the **ENTER** key to display the mode selection window.

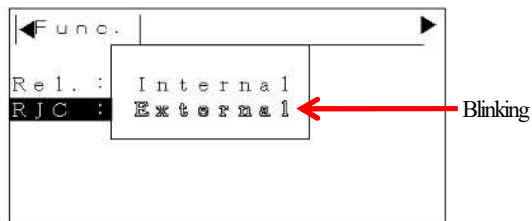

⑥ Select <Internal> with the cursor key.

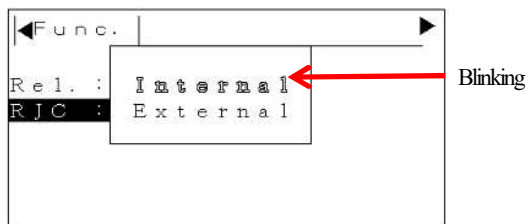

⑦ Push the **ENTER** key for setting.

⑧ Push the **ESC** key to get back to the monitor window.

MEMO

Default setting is Internal Mode.

(Blank page)

7. MENU LIST

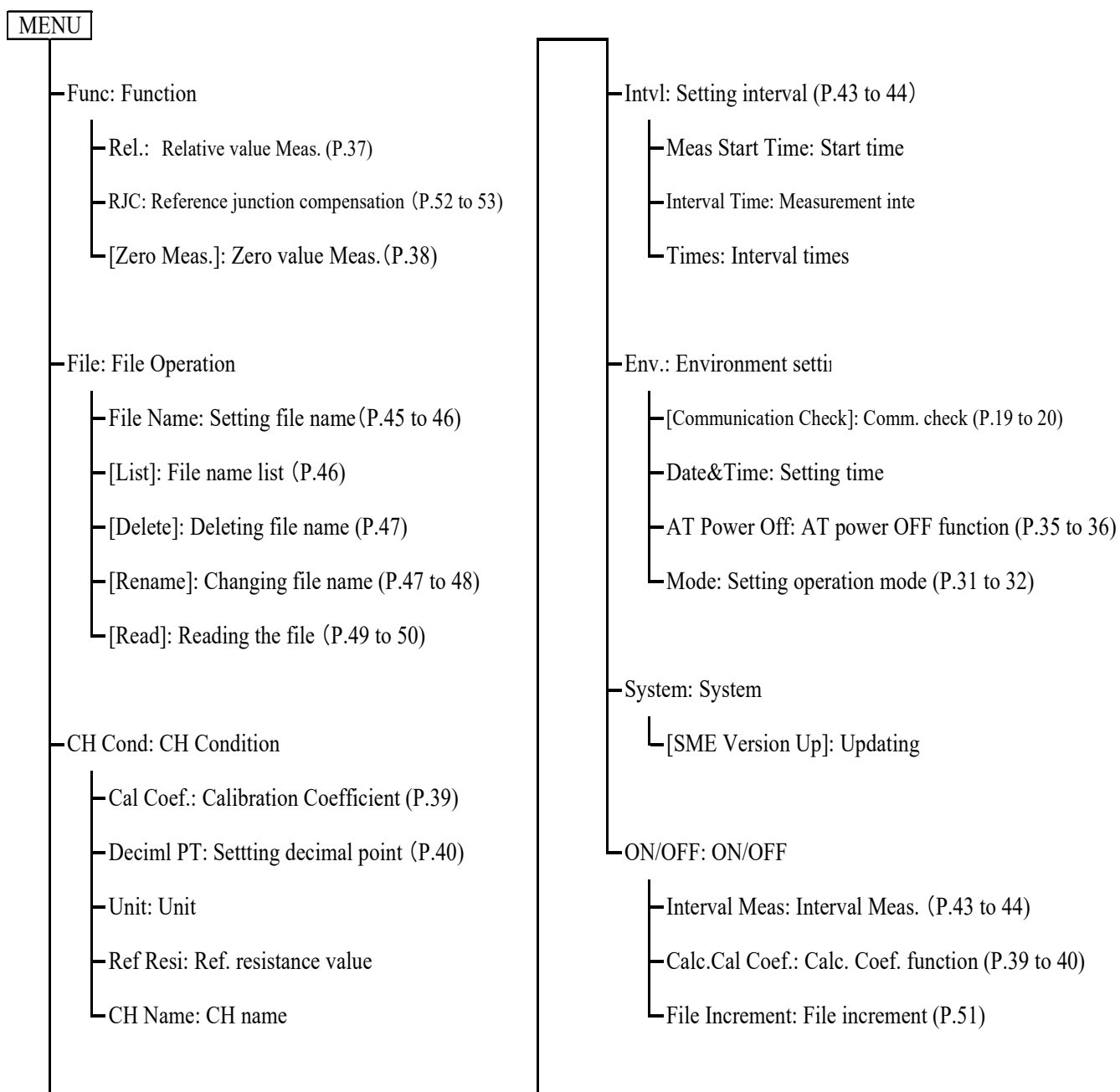

8. TROUBLE SHOOTING

In case the following trouble occurs, take appropriate countermeasures according to the check items in the following table.
If the same phenomenon still generates after taking the following countermeasures, contact KYOWA or our representatives.

• SME Series

Phenomenon	Check Items
The LCD does not display.	<ul style="list-style-type: none"> • Is the dry cell or AC adapter securely connected? → Securely connect the dry cell or AC adapter. • Are the dry cells in the right way? → Correctly insert the dry cells. • The dry cells have reached the end of its service life. → Replace the dry cells with new ones.
Operation stops and accepts no instruction at all.	<ul style="list-style-type: none"> • The noise source is close to the SME series. → Turn OFF the power and turn ON again. <p>If the same phenomenon still generates due to noise, take appropriate countermeasures for removing the noise from operating environment, power supply, etc.</p>
The measured value varies. The measured values are incorrect.	<ul style="list-style-type: none"> • Are the installed sensors loosen? → Securely install the sensors. • The noise source is close to the SME series. → Take appropriate countermeasures for removing the noise. • Are correct sensors and correct cables connected? → Use correct sensors. Correctly set and connect them.
Data cannot be saved in the SD card.	<ul style="list-style-type: none"> • Is the SD card securely inserted? → Securely insert the SD card. • Is the SD card formatted in the FAT file system? → Format the SD card in the FAT file system. • Check to see if the SD card is locked. → Make sure the lock switch of the SD card is unlock position.
The SME series cannot communicate with the NTB. (SME-100A/101A only)	<ul style="list-style-type: none"> • Are the dedicated communication cables used? → Use the dedicated communication cables. • Check whether the power of the NTB is ON or OFF. → Turn ON the NTB.

• SMET-1A

Phenomenon	Check Items
The measured data appears as <----->.	<ul style="list-style-type: none"> • Are the SME and SMET-1A securely connected? → Securely connect the SMET-1A to the SME.
The measured value varies. The measured values are incorrect.	<ul style="list-style-type: none"> • Is the thermocouple loosen? → Securely install the thermocouple. • The noise source is close to the SME series. → Take appropriate countermeasures for removing the noise. • Is the correct thermocouple connected? → Use the correct thermocouple. • Is the pre-set input mode correct? → Set the input mode correctly.

9. SPECIFICATIONS

HANDY DATA LOGGER: SME — 30A/31A

- (1) Number of measuring CHs 1
- (2) Sampling period
 Approx. 0.5 sec : 0 to ± 30000 $\mu\text{m}/\text{m}$
 Approx. 1 sec : ± 30000 to ± 300000 $\mu\text{m}/\text{m}$
 : Measurement with civil engineering transducer with temperature measuring function
- (3) Measuring function
 RELATIVE measurement (relative value measurement):
 Each value is obtained by deducting the ZERO value.
 *ZERO value is equivalent to the initial unbalance value.
 Capable of obtaining the ZERO value at arbitrary timing.
- (4) Coefficient calculation function None
- (5) Compatible Sensor
 Strain gage
 Strain gage transducer
 Civil engineering transducer with temperature measuring function

Gage method	Compatible gage resistance
Quarter bridge	120, 240, 350 ohm
Half or Full bridge	120 to 1000 ohm

- (6) Bridge excitation
 Constant-voltage bridge excitation: Approx. 2 VDC
 Constant-current bridge excitation: Approx. 5.6 mA (Bridge resistance: 350 ohm)
- (7) Measuring Range
 Strain:
 0 to ± 300000 $\mu\text{m}/\text{m}$ (Constant-voltage bridge excitation)
 0 to ± 20000 $\mu\text{m}/\text{m}$ (Constant-current bridge excitation)
 Temperature measurement with civil engineering transducer with temperature measuring function
 -30.0 to 70.0°C
- (8) Resolution
 Strain:
 0 to ± 300000 $\mu\text{m}/\text{m}$: $1\mu\text{m}/\text{m}$
 ± 30000 to ± 300000 $\mu\text{m}/\text{m}$: $10\mu\text{m}/\text{m}$
 Temperature measurement with civil engineering transducer with temperature measuring function
 0.1°C
- (9) Accuracy (when connected with NDIS 4102(7pins) connector)
 Strain:
 0 to ± 30000 $\mu\text{m}/\text{m}$: $\pm(0.05\% \text{rdg} + 2) \mu\text{m}/\text{m}$
 ± 30000 to ± 300000 $\mu\text{m}/\text{m}$: $\pm(0.1\% \text{rdg} + 20) \mu\text{m}/\text{m}$
 Temperature measurement with civil engineering transducer with temperature measuring function
 Temperature: $\pm 0.5^\circ\text{C}$
- (10) Check function
 Insulation resistance measurement: 2 M to 100 Mohm
 Resistance measurement: 0 to 20 kohm

(11) Interval measurement	1 minute to 99 hours 59 minutes in 1-minute steps Starting date/time: Year/month/day, hour: minute
(12) Storage	SD card
(13) Compatible card	256MB, 512MB, 1GB, 2GB (FAT16) (SDHC is not compatible)
(14) Display	Monochrome LCD, 128 × 64 dots
(15) TEDS	Reading function from the TEDS sensor CH name writing function (For the manufacture ID: KYOWA only, within 10 characters)
(16) Operating temperature/Humidity range	-10 to 50°C, 20 to 85% (non-condensing)
(17) Power supply	Size AA alkaline dry cell (×2) Continuous operation: Approx 10 hours (with alkaline batteries) *SME-31A is compliant to the AC adapter (optional)
(18) Auto power OFF	Power is automatically turned OFF if no key operation is done for 5 minutes. In interval measurement mode with the interval set at 3 minutes or longer, it is automatically turned OFF during standby period but it is turned ON again 1 minute before the next measurement time comes. (Auto power OFF function can be set to ON or OFF.)
(19) Dimensions	188(W) × 108.4(H) × 41(D) mm (Excluding protrusions)
(20) Weight	Approx. 450 g (without including batteries)
(21) Standard accessories	Instruction Manual (CD-R) Input cable Size AA alkaline dry cell (×2) Shoulder strap Wrist strap
(22) Compliance	Directive 2014/30/EU (EMC) Directive 2011/65/EU, (EU)2015/863 (10 restricted substances) (RoHS)

HANDY DATA LOGGER: SME—100A/101A

- (1) Number of measuring CHs 1 (When using the single SME series)
 NTB enables sequential measurement in a maximum 33 CHs
 *MAX. 33 CH (SME series 1 CH + 8 units of the NTB (32 CHs))
- (2) Sampling period (When using the single SME series.
 Varies with the connecting NTB.)
 Approx. 0.5 sec : 0 to ± 30000 $\mu\text{m}/\text{m}$
 Approx. 1 sec : ± 30000 to ± 300000 $\mu\text{m}/\text{m}$
 Measurement with civil engineering transducer with temperature measuring function
- (3) Measuring function RELATIVE measurement (relative value measurement):
 Each value is obtained by deducting the ZERO value.
 *ZERO value is equivalent to the initial unbalance value.
 Capable of obtaining the ZERO value at arbitrary timing.
- (4) Coefficient calculation function None
- (5) Compatible Sensor Strain gage
 Strain gage transducer
 Civil engineering transducer with temperature measuring function

Gage method	Compatible gage resistance
Quarter bridge	120, 240, 350 ohm
Half or Full bridge	120 to 1000 ohm

- (6) Bridge excitation Constant-voltage bridge excitation: Approx. 2 VDC
 Constant-current bridge excitation: Approx. 5.6 mA (Bridge resistance: 350 ohm)
- (7) Measuring Range
 Strain:
 0 to ± 300000 $\mu\text{m}/\text{m}$ (Constant-voltage bridge excitation)
 0 to ± 20000 $\mu\text{m}/\text{m}$ (Constant-current bridge excitation)
 Temperature measurement with civil engineering transducer with temperature measuring function
 -30.0 to 70.0°C
- (8) Resolution
 Strain:
 0 to ± 300000 $\mu\text{m}/\text{m}$: $1\mu\text{m}/\text{m}$
 ± 30000 to ± 300000 $\mu\text{m}/\text{m}$: $10\mu\text{m}/\text{m}$
 Temperature measurement with civil engineering transducer with temperature measuring function
 0.1°C
- (9) Accuracy (when connected with NDIS 4102(7pins) connector)
 Strain:
 0 to ± 30000 $\mu\text{m}/\text{m}$: $\pm(0.05\% \text{rdg} + 2) \mu\text{m}/\text{m}$
 ± 30000 to ± 300000 $\mu\text{m}/\text{m}$: $\pm(0.1\% \text{rdg} + 20) \mu\text{m}/\text{m}$
 Temperature measurement with civil engineering transducer with temperature measuring function
 $\pm 0.5^\circ\text{C}$
- (10) Check function
 Insulation resistance measurement: 2 M to 100 Mohm
 Resistance measurement: 0 to 20 kohm

(11) Interval measurement	1 minute to 99 hours 59 minutes in 1-minute steps Starting date/time: Year/month/day, hour: minute
(12) Storage	SD card
(13) Compatible card	256MB, 512MB, 1GB, 2GB (FAT16) (SDHC is not compatible)
(14) Display	Monochrome LCD, 128 × 64 dots
(15) TEDS	Reading function from the TEDS sensor CH name writing function (For the manufacture ID: KYOWA only, within 10 characters)
(16) Operating temperature/Humidity range	-10 to 50°C, 20 to 85% (non-condensing)
(17) Power supply	Size AA alkaline dry cell (×2) Continuous operation: Approx 10 hours (with alkaline batteries) *SME-31A is compliant to the AC adapter (optional)
(18) Auto power OFF	Power is automatically turned OFF if no key operation is done for 5 minutes. In interval measurement mode with the interval set at 3 minutes or longer, it is automatically turned OFF during standby period but it is turned ON again 1 minute before the next measurement time comes. (Auto power OFF function can be set to ON or OFF.)
(19) Dimensions	188(W) × 108.4(H) × 41(D) mm (Excluding protrusions)
(20) Weight	Approx. 450 g (without including batteries)
(21) Standard accessories	Instruction Manual (CD-R) Input cable, Communication Cable Size AA alkaline dry cell (×2) Shoulder strap Wrist strap
(22) Compliance	Directive 2014/30/EU (EMC) Directive 2011/65/EU,(EU)2015/863(10 restricted substances) (RoHS)

THERMOCOUPLE ADAPTER FOR SME: SMET-1A

- (1) Number of measuring CHs 1
- (2) Sampling period Approx. 0.5 sec
- (3) Compatible Sensor Thermocouple (K type and T type)
- (4) Input Terminal block
Available wires Solid wire: UL AWG14 to AWG28
Stranded wire: UL AWG20 to AWG24
- (5) Measuring range, Accuracy, Resolution, Reference junction compensation

Types	Measuring Range	Resolution	Accuracy		Internal Reference Junction Compensation (25±10°C)
K type	-200.0 ~ 1230.0°C	0.1°C	-200.0 to lower than -100.0°C	± (0.2%rdg+0.6) °C	±2.0°C
			-100.0 ~ 1230.0°C	± (0.1%rdg+0.4) °C	±1.0°C
T type	-200.0 ~ 400.0°C		-200.0 to lower than -100.0°C	± (0.2%rdg+0.6) °C	±2.0°C
			-100.0 ~ 400.0°C	± (0.1%rdg+0.4) °C	±1.0°C

*The accuracy of sensors is not included.

*The reference junction compensation can be set to the internal or external by from the SME series.

* Resistance of the thermocouples are 1kΩ or less.

- (6) Check function Burnout Checking (can be conduct from the SME series)
- (7) Operating temperature/humidity range: -10 to 50°C, 20 to 85% (non-condensing)
- (8) Dimensions 42(W) × 33(H) × 29.5(D) mm (Excluding protrusions)
- (9) Weight Approx. 35 g
- (10) Standard accessories Instruction Manual (CD-R)
Mounting screws

This product does not contain the 10 restricted substances beyond the maximum concentration limit under RoHS Directive (2011/65/EU, (EU)2015/863). * Excluding exemptions allowed under RoHS directive (2011/65/EU, (EU)2015/863).

10. OUTSIDE DRAWING

- SME Series

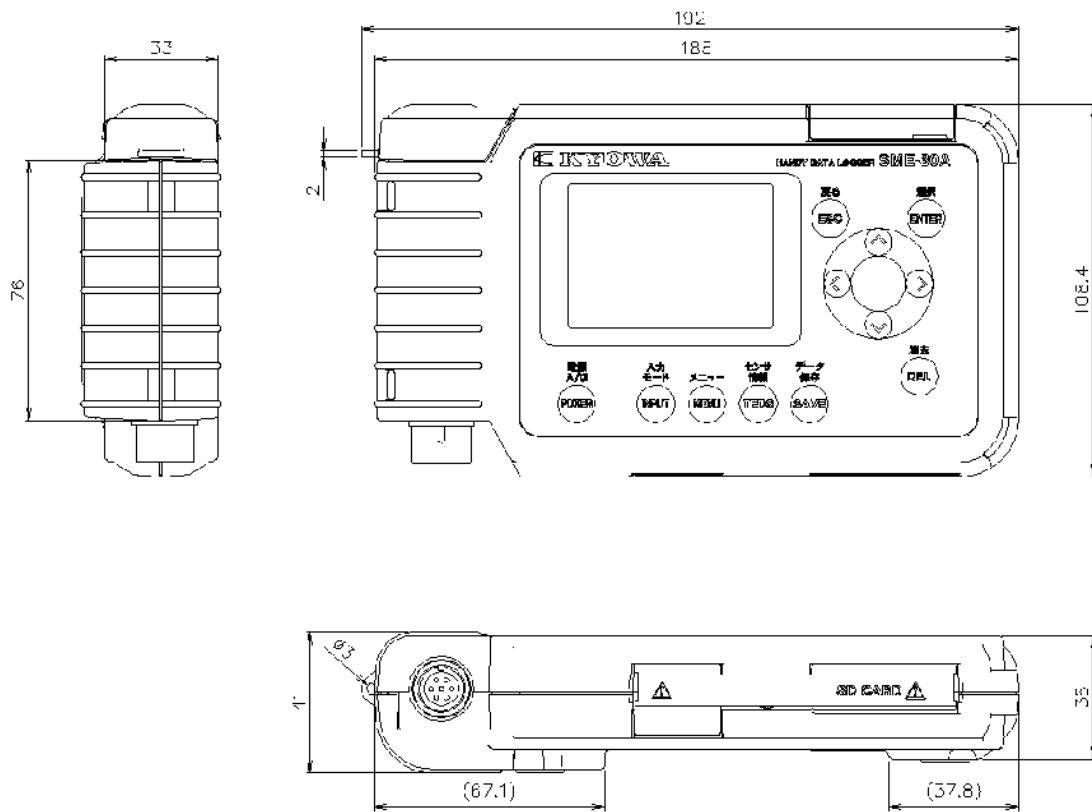

*All models have the same dimensions.
Model No. on the product is different.

- SMET-1A

